



Massachusetts Cannabis Control Commission

Marijuana Retailer

General Information:

License Number: MR281950
Original Issued Date: 01/23/2019
Issued Date: 01/14/2021
Expiration Date: 01/23/2022

ABOUT THE MARIJUANA ESTABLISHMENT

Business Legal Name: Sanctuary Medicinals, Inc.

Phone Number: 646-573-3462
Email Address: jweaver@sanctuarymed.com

Business Address 1: 1351 Beacon Street
Business City: Brookline Business State: MA Business Zip Code: 02446
Business Address 2:
Mailing Address 1: 234 Taylor Street
Mailing City: Littleton Mailing State: MA Mailing Zip Code: 01460
Mailing Address 2:

CERTIFIED DISADVANTAGED BUSINESS ENTERPRISES (DBES)

Certified Disadvantaged Business Enterprises (DBEs): Not a DBE

PRIORITY APPLICANT

Priority Applicant: yes
Priority Applicant Type: RMD Priority
Economic Empowerment Applicant Certification Number:
RMD Priority Certification Number: RPA201958

RMD INFORMATION

Name of RMD: Sanctuary Medicinals, Inc.
Department of Public Health RMD Registration Number: 030
Operational and Registration Status: Obtained Final Certificate of Registration, but is not open for business in Massachusetts
To your knowledge, is the existing RMD certificate of registration in good standing?: yes
If no, describe the circumstances below:

PERSONS WITH DIRECT OR INDIRECT AUTHORITY

Person with Direct or Indirect Authority 1

Percentage Of Ownership: Percentage Of Control: 33.33
Role: Executive / Officer Other Role: President, Director, Treasurer, CEO
First Name: Jason Last Name: Sidman Suffix:

CLOSE ASSOCIATES AND MEMBERS

Close Associates or Member 1

First Name: Michael Last Name: Allen Suffix:

Describe the nature of the relationship this person has with the Marijuana Establishment: Chief of Security

Close Associates or Member 2

First Name: David Last Name: Syrek Suffix: MD

Describe the nature of the relationship this person has with the Marijuana Establishment:

Director

Close Associates or Member 3

First Name: Michael Last Name: Wilmoth Suffix:

Describe the nature of the relationship this person has with the Marijuana Establishment:

Director

Close Associates or Member 4

First Name: Nicholas Last Name: Satmary Suffix:

Describe the nature of the relationship this person has with the Marijuana Establishment: Director of Cultivation

Close Associates or Member 5

First Name: Joshua Last Name: Weaver Suffix:

Describe the nature of the relationship this person has with the Marijuana Establishment: Chief Financial Officer

Close Associates or Member 6

First Name: Jason Last Name: Sidman Suffix:

Describe the nature of the relationship this person has with the Marijuana Establishment: Chief Executive Officer, Director, President, Treasurer

CAPITAL RESOURCES - INDIVIDUALS

No records found

CAPITAL RESOURCES - ENTITIES

Entity Contributing Capital 1

Entity Legal Name: Premier Healthcare Group, LLC

Entity DBA:

Email: jweaver@sanctuaryatc.org

Phone: 646-573-3462

Address 1: 234 Taylor Street

Address 2:

City: Littleton

State: MA

Zip Code: 01460

Types of Capital: Monetary/Equity,

Other Type of Capital:

Total Value of Capital Provided:

Percentage of Initial Capital:

Debt

\$11000000

100

Capital Attestation: Yes

BUSINESS INTERESTS IN OTHER STATES OR COUNTRIES

No records found

DISCLOSURE OF INDIVIDUAL INTERESTS

Individual 1

First Name: Jason

Last Name: Sidman

Suffix:

Marijuana Establishment Name: Sanctuary ATC

Business Type: Other

Marijuana Establishment City: Rochester, Plymouth - Vertically Integrated Operator

Marijuana Establishment State: NH

Individual 2

First Name: Joshua **Last Name:** Weaver **Suffix:**
Marijuana Establishment Name: Sanctuary ATC **Business Type:** Other
Marijuana Establishment City: Rochester, Plymouth - Vertically Integrated Operator **Marijuana Establishment State:** NH

MARIJUANA ESTABLISHMENT PROPERTY DETAILS

Establishment Address 1: 1351 Beacon Street
Establishment Address 2:
Establishment City: Brookline **Establishment Zip Code:** 02446
Approximate square footage of the establishment: 4997 **How many abutters does this property have?:**
157
Have all property abutters been notified of the intent to open a Marijuana Establishment at this address?: Yes

HOST COMMUNITY INFORMATION

Host Community Documentation:

Document Category	Document Name	Type	ID	Upload Date
Plan to Remain Compliant with Local Zoning	CCC.Plan to Remain Compliant With Local Zoning Brookline.pdf	pdf	5bbb5b502f2ea102ad5b7af9	10/08/2018
Community Outreach Meeting Documentation	CCC.Brookline Community Meeting.pdf	pdf	5bbf4a1748682102a3cf62f1	10/11/2018
Certification of Host Community Agreement	CCC.Brookline HCA Verification.PDF	pdf	5bda0c4fbcbac00d7d74a5e1	10/31/2018

Total amount of financial benefits accruing to the municipality as a result of the host community agreement. If the total amount is zero, please enter zero and provide documentation explaining this number.: \$100000

PLAN FOR POSITIVE IMPACT

Plan to Positively Impact Areas of Disproportionate Impact:

Document Category	Document Name	Type	ID	Upload Date
Plan for Positive Impact	CCC.Plan to Positively Impact Areas of Disproportionate Impact.pdf	pdf	5bbb5d87a18c210c3243116d	10/08/2018

ADDITIONAL INFORMATION NOTIFICATION

Notification: I understand

INDIVIDUAL BACKGROUND INFORMATION

Individual Background Information 1

Role: **Other Role:**
First Name: Jason **Last Name:** Sidman **Suffix:**
RMD Association: RMD Manager
Background Question: no

Individual Background Information 2

Role: **Other Role:**

First Name: Michael Last Name: Wilmoth Suffix:

RMD Association: RMD Staff

Background Question: no

Individual Background Information 3

Role: Other Role:

First Name: David Last Name: Syrek Suffix:

RMD Association: RMD Staff

Background Question: no

Individual Background Information 4

Role: Other Role:

First Name: Joshua Last Name: Weaver Suffix:

RMD Association: RMD Manager

Background Question: no

Individual Background Information 5

Role: Other Role:

First Name: Nicholas Last Name: Satmary Suffix:

RMD Association: RMD Manager

Background Question: no

Individual Background Information 6

Role: Other Role:

First Name: Michael Last Name: Allen Suffix:

RMD Association: RMD Manager

Background Question: no

ENTITY BACKGROUND CHECK INFORMATION

Entity Background Check Information 1

Role: Investor/Contributor Other Role: Investment Entity

Entity Legal Name: Premier Healthcare Group LLC Entity DBA:

Entity Description: Investment Entity

Phone: 646-573-3462 Email: jweaver@sanctuarymed.com

Primary Business Address 1: 125 Summer Street Primary Business Address 2:

Primary Business City: Boston Primary Business State: MA Principal Business Zip Code: 02110

Additional Information: Premier Healthcare Group LLC is the investment entity of Sanctuary Medicinals, Inc.

Entity Background Check Information 2

Role: Other (specify) Other Role: Managing Entity

Entity Legal Name: PHG, LLC Entity DBA:

Entity Description: Managing Entity

Phone: 646-573-3462 Email: jweaver@sanctuarymed.com

Primary Business Address 1: 125 Summer Street Primary Business Address 2:

Primary Business City: Boston Primary Business State: MA Principal Business Zip Code: 02110

Additional Information: PHG, LLC is the managing entity of Premier Healthcare Group LLC

MASSACHUSETTS BUSINESS REGISTRATION

Required Business Documentation:

Document Category	Document Name	Type	ID	Upload Date
Department of Revenue - Certificate of Good standing	SM- Cert of GS (DOR).pdf	pdf	5bbb6809658c0f0c3ca79c75	10/08/2018
Articles of Organization	CCC.ArticlesofOrg.pdf	pdf	5bbb682a3fbe330c461d13cb	10/08/2018
Bylaws	CCC.Bylaws.pdf	pdf	5bbb68362d28790c50080a73	10/08/2018
Secretary of Commonwealth - Certificate of Good Standing	CCC. Cert of GS (SOS).pdf	pdf	5bbb6872629ac50c14735537	10/08/2018

Certificates of Good Standing:

Document Category	Document Name	Type	ID	Upload Date
Department of Revenue - Certificate of Good standing	SM.CertofGS.DofR.pdf	pdf	5dd2a78f9c1081532b9a5940	11/18/2019
Department of Unemployment Assistance - Certificate of Good standing	SM.CertofGS.Unemp.pdf	pdf	5dd2a823fd468857b99bc7ca	11/18/2019
Secretary of Commonwealth - Certificate of Good Standing	SM.CertofGS.SecofCom.pdf	pdf	5dd2a86a7aad8653363bd438	11/18/2019
Department of Unemployment Assistance - Certificate of Good standing	SM.CertofGS.Unemp.pdf	pdf	5f982a50bd0d8e081433a8ff	10/27/2020
Department of Revenue - Certificate of Good standing	SM.CertofGS.Revenue.pdf	pdf	5f997d6f3bf49c082a4241e6	10/28/2020
Secretary of Commonwealth - Certificate of Good Standing	SM.CertofGS.SOS.pdf	pdf	5f9c1d404a2789086108ba65	10/30/2020

Massachusetts Business Identification Number: 001335444

Doing-Business-As Name:

DBA Registration City:

BUSINESS PLAN

Business Plan Documentation:

Document Category	Document Name	Type	ID	Upload Date
Plan for Liability Insurance	CCC.Insurance.pdf	pdf	5bbb6910658c0f0c3ca79c79	10/08/2018
Business Plan	CCC.MOP.BusinessPlan.Brookline.pdf	pdf	5bbb6afa629ac50c1473553b	10/08/2018
Proposed Timeline	Sanctuary_Updated Timeline_1.6.20.pdf	pdf	5e13742def24345344e5093e	01/06/2020

OPERATING POLICIES AND PROCEDURES

Policies and Procedures Documentation:

Document Category	Document Name	Type	ID	Upload Date
Qualifications and training	CCC.Qualifications and Training.pdf	pdf	5bbb6c4fa5b0140c1e4b8e8e	10/08/2018
Diversity plan	CCC.Diversity Plan.pdf	pdf	5bbb6c62f70a1a0c28f75b50	10/08/2018
Maintaining of financial records	CCC.Maintaining of Financial Records.pdf	pdf	5bbb6c85658c0f0c3ca79c7f	10/08/2018

Record Keeping procedures	CCC.Recordkeeping Procedures.pdf	pdf	5bbb6c9c3fbe330c461d13d3	10/08/2018
Dispensing procedures	CCC.Dispensing Procedures.pdf	pdf	5bbb6cb02d28790c50080a7b	10/08/2018
Quality control and testing	CCC.Quality Control and Testing.pdf	pdf	5bbb6cc5c4bce20c0e8e152c	10/08/2018
Inventory procedures	CCC.Inventory Procedures.pdf	pdf	5bbb6cd5629ac50c14735541	10/08/2018
Transportation of marijuana	CCC.Transportation of Marijuana.pdf	pdf	5bbb6ceaa5b0140c1e4b8ec2	10/08/2018
Storage of marijuana	CCC.Storage of Marijuana.pdf	pdf	5bbb6cfaf70a1a0c28f75b54	10/08/2018
Prevention of diversion	CCC.Prevention of Diversion.pdf	pdf	5bbb6d07a18c210c3243118e	10/08/2018
Restricting Access to age 21 and older	CCC.Plan for Restricting Access to Age 21 and Older.pdf	pdf	5bbb6d19658c0f0c3ca79c83	10/08/2018
Plan for obtaining marijuana or marijuana products	CCC.Plan for Obtaining Marijuana or Marijuana Products.pdf	pdf	5bbb6d4e3fbe330c461d13d7	10/08/2018
Security plan	CCC.Security Plan Retail.Brookline.pdf	pdf	5bbb6eb63fbe330c461d13db	10/08/2018
Personnel policies including background checks	Sanctuary_Personnel Polices_Retailer.pdf	pdf	5bbb6f1bf70a1a0c28f75b5c	10/08/2018
Separating recreational from medical operations, if applicable	CCC.Plan for Separating Recreational from Medical Operations.Brookline.pdf	pdf	5bbf4c044253fa027574f0c1	10/11/2018
Energy Compliance Plan	Sanctuary Medicinals Energy Compliance Letter_Part3.pdf	pdf	5fad92d83bf49c082a426ed2	11/12/2020
Energy Compliance Plan	Sanctuary Medicinals Energy Compliance Letter_Part4.pdf	pdf	5fad92d9dd2d7407bedeca72	11/12/2020
Energy Compliance Plan	Sanctuary Medicinals Energy Compliance Letter_Part5.pdf	pdf	5fad92db8cc05c081b1b7e52	11/12/2020
Energy Compliance Plan	Sanctuary Medicinals Energy Compliance Letter_Part1.pdf	pdf	5fad92dca75869080486cadd	11/12/2020
Energy Compliance Plan	Sanctuary Medicinals Energy Compliance Letter_Part2.pdf	pdf	5fad92dedfc9f07cd945901	11/12/2020
Energy Compliance Plan	Sanctuary Medicinals Energy Compliance Letter_Part8.pdf	pdf	5fad92ff75aac308359ad9a1	11/12/2020
Energy Compliance Plan	Sanctuary Medicinals Energy Compliance Letter_Part9.pdf	pdf	5fad9301dd2d7407bedeca76	11/12/2020
Energy Compliance Plan	Sanctuary Medicinals Energy Compliance Letter_Part10.pdf	pdf	5fad9305a75869080486cae1	11/12/2020
Energy Compliance Plan	Sanctuary Medicinals Energy Compliance Letter_Part6.pdf	pdf	5fad9306edc7d60856d97f40	11/12/2020
Energy Compliance Plan	Sanctuary Medicinals Energy Compliance Letter_Part7.pdf	pdf	5fad930b08242707d4a78766	11/12/2020
Energy Compliance Plan	Sanctuary Medicinals Energy Compliance Letter_Part13.pdf	pdf	5fad93303bf49c082a426ed8	11/12/2020
Energy Compliance Plan	Sanctuary Medicinals Energy Compliance Letter_Part14.pdf	pdf	5fad9331dd2d7407bedeca7a	11/12/2020
Energy Compliance Plan	Sanctuary Medicinals Energy Compliance Letter_Part15.pdf	pdf	5fad93328cc05c081b1b7e56	11/12/2020
Energy Compliance Plan	Sanctuary Medicinals Energy Compliance Letter_Part11.pdf	pdf	5fad9336a75869080486cae5	11/12/2020

Energy Compliance Plan	Sanctuary Medicinals Energy Compliance Letter_Part12.pdf	pdf	5fad9339dfcf9f07cd945905	11/12/2020
Energy Compliance Plan	Sanctuary Medicinals Energy Compliance Letter_Part17.pdf	pdf	5fad9335f57d9d707ee4d90be	11/12/2020
Energy Compliance Plan	Sanctuary Medicinals Energy Compliance Letter_Part16.pdf	pdf	5fad936075aac308359ad9a7	11/12/2020

MARIJUANA RETAILER SPECIFIC REQUIREMENTS

No documents uploaded

No documents uploaded

ATTESTATIONS

I certify that no additional entities or individuals meeting the requirement set forth in 935 CMR 500.101(1)(b)(1) or 935 CMR 500.101(2)(c)(1) have been omitted by the applicant from any marijuana establishment application(s) for licensure submitted to the Cannabis Control Commission.: I Agree

I understand that the regulations stated above require an applicant for licensure to list all executives, managers, persons or entities having direct or indirect authority over the management, policies, security operations or cultivation operations of the Marijuana Establishment; close associates and members of the applicant, if any; and a list of all persons or entities contributing 10% or more of the initial capital to operate the Marijuana Establishment including capital that is in the form of land or buildings.: I Agree

I certify that any entities who are required to be listed by the regulations above do not include any omitted individuals, who by themselves, would be required to be listed individually in any marijuana establishment application(s) for licensure submitted to the Cannabis Control Commission.: I Agree

Notification: I Understand

I certify that any changes in ownership or control, location, or name will be made pursuant to a separate process, as required under 935 CMR 500.104(1), and none of those changes have occurred in this application.: I Agree

I certify that to the best knowledge of any of the individuals listed within this application, there are no background events that have arisen since the issuance of the establishment's final license that would raise suitability issues in accordance with 935 CMR 500.801.: I Agree

I certify that all information contained within this renewal application is complete and true.: I Agree

ADDITIONAL INFORMATION NOTIFICATION

Notification: I Understand

COMPLIANCE WITH POSITIVE IMPACT PLAN

Progress or Success Goal 1

Description of Progress or Success: Sanctuary Medicinals (the "Company") will be a long-term member and good neighbor in the communities it serves, and with that, the Company is focused on developing a guided pathway that can positively address the long-term needs of those who have been disproportionately impacted by the war on drugs, specifically in Fitchburg, Lowell and Boston. This approach, in concert with addressing the more immediate needs in these communities, will deliver positive outcomes for those residing in these areas. While the Company is still in its start-up phase, it is beginning to execute a plan that has the potential to change the lives of many who have been disproportionately impacted by the war on drugs.

a. Conduct industry-specific educational seminars in one or more of the following areas: marijuana cultivation, product manufacturing, retail, or business training.

The Company's progress in developing a cannabis certificate/micro-credential program with Mount Wachusett Community College (MWCC) has slowed to a stop for the time being due to unpredictability of Covid-19. In the future however, the goal is for credits earned in this program to be stackable towards a credit degree-track if the program is revisited.

MWCC originally approached the Company's CEO, Jason Sidman, in 2018 for exploratory conversations about the development of a certificate/

credential program. During these exploratory conversations, both parties agreed to speak again in the summer of 2019 after the Company was operational. MWCC re-engaged with the Company in summer 2019 to begin establishing a collaborative program however it has since dissipated because of the pandemic.

Syllabi had been scheduled to include hands-on skill-set development training at the Company's grow facility and dispensary facilities. Syllabi topics were to include propagation and cultivation, whole plant curing, drying and processing, active compound extraction, product & food manufacturing, sanitation, inventory control and seed to sale regulatory requirements, retail dispensing, and soft-skills development including customer and patient interface.

Syllabi was to be developed for on-campus courses including but not limited to cannabis business development, product identification and specification, delivery systems, dosing, cannabinoids and terpenes, dispensary management, substance abuse and soft-skills development. The outcome would have been a workforce-ready graduate who could seamlessly integrate into the burgeoning cannabis industry as a career path, delivering a sustainable quality of life for individuals and families alike. Parts of this program were projected to begin running in the Spring Semester (January 2020) and the full program to be operational by Summer, 2020 however this has since had to change its course.

The Company however has continued to establish training programs that are industry specific by building up our internal training platform. The information will be used as a base platform for future learning endeavors explored by the company. Currently the training documents are used to educate internal staff members in both retail and production facilities for continuing education in many of the areas mentioned above. The expansion of our ongoing internal training helps the Company ensure staff members are knowledgeable about their roles and the nature of the business to ensure they are on the best path for success. Upon completion of training team members are to sign off on their training logs or a training signup sheet to confirm they understand the material covered.

Other internal training will include the coverage of topics like sexual harassment in the workplace, workplace bullying and violence, active shooter and active threat, safety trainings, and other important topics as they arise. Each training session will be followed by a quiz or group discussion in which documents will be kept for internal employee records. Various training seminars will be based on internally created content as well as externally created content such as DVDs provided by J. J. Keller & Associates, Inc.

Progress or Success Goal 2

Description of Progress or Success: b. Donate to the Social Equity Training and Technical Assistance Fund.

The Company is establishing a scholarship fund with a working title of "Ready-SET-Go" (SET = Social Equity Training) to address tuition and other college-related needs of those underserved individuals in Fitchburg and Lowell who want to enroll in MWCC's certificate/credential program(s) in order to jump-start a career into the cannabis workplace, but who lack the financial capabilities to do so. Ready-SET-Go will be seeded annually by the Company with an initial placeholder of \$5,000 for the sole purpose of granting scholarships with a specific focus on those incarcerated for low-level cannabis offenses. The Ready-Set-Go account will increase over time as the Company will continue to increase the dollar amount. The Company has increased the fund's annual giving capabilities by contributing an additional \$5,000 donation to the Ready-SET-Go scholarship fund in 2020. To date the account holds \$10,000 and will continue to grow as the company efforts expand. Additionally, the Company will look to its vendors and other professional business relationships to make donations to the Ready-SET-Go scholarship fund, with the goal of increasing the fund's annual giving capabilities.

c. Provide financial mentoring services or host organizations that provide these services.

Originally the Company in partnership with the MWCC created a curriculum that specified a focus on the financials of a cannabis business. This included but was not be limited to business plan development, revenue & expense projections, reading and understanding a P&L, determining per unit costs for food and non-food products, budgetary forecasts and basic accounting principles. Additionally and as part of the MWCC's program, the Company had agreed to offer one-on-one industry advisement and mentoring support with students doing their internships at the Company on a wide range of subjects and as part of the student's guided pathway towards funding opportunities and business ownership. With the current changes in both the MWCC safety protocols including virtual training and the Company's commitment to safety during COVID-19 the mentoring program has been redirected. A second attempt to create an internal program is in place and is undergoing the approval and proposal process internally. This effort to build an internal mentor program will be a much bigger project to tackle as it will need to be built from the ground up. Attached in this renewal is a base proposal of what the projected program could look like. This program along with the goals are subject to change.

d. Hold monthly informational sessions regarding the process for sealing and expunging criminal records.

Mount Wachusett Community College has in-depth experience in this area. Sanctuary has stated to MWCC that the Company fully supports assisting in informational sessions and will be using its marketing resources to promote these College-driven pathways.

To accommodate for safety practices during the COVID 19 pandemic we have chosen to move our informational sessions to an online platform. The Company has chosen to utilize the Sanctuary Blog to educate consumers on how to expunge and seal records.

e. Partner with and support organizations that provide jail diversion and restorative justice programs.

The MWCC and the Company's collaboration for operation has been delayed and was originally targeted for early 2020. If the Company and MWCC choose to continue the Company will be marketing a "From Incarceration to Cannabis Industry" program to allow non-felons, access to the cannabis industry through the programs offered by the MWCC and the Company. These candidates will be given preferential treatment for scholarship assistance and job placement within the Company's network, upon satisfactory completion of their course studies. For now, the program remains on hold because of COVID19.

The Company has chosen to remain committed to our promise to support and partner with organizations that provide jail diversion and restorative justice programs for those directly impacted by cannabis prohibition even after our halt in our collaborative project with MWCC due to COVID19. The Company has chosen to give periodic donations to The Last Prisoners Project, a non-profit whose focus is on advocacy, intervention, and awareness campaigns that help those who are currently being harmed by the unjust laws and policies still in place from the War on Drugs. The focus of The Last Prisoners Project is to release and rebuild the lives of those suffering from cannabis related crimes even after legalization. Our contribution to The Last Prisoners Project has been asked to be put toward helping those in Massachusetts gain access to the resources they need to be free from their past crime through exit programs, record clearing, and re-entry programs. Our contacts at The Last Prisoner Project are Cam Boucher cam@lastprisonersproject.org and Mary Bailey mary@lastprisonersproject.org.

The Company has been and continues to be an advocate for the MORE Act (s.2227 – 116) Congress (2019-2020), as it the first piece of federal legislation that would establish social equity programs for cannabis entrepreneurs, and it would enact wholesale expungements of prior low-level cannabis offenses for federal convicts. Additionally, convicts currently serving time in federal prisons for cannabis violations would also receive reductions to their sentences.

f. Institute hiring practices that prioritize the hiring of individuals from disproportionately impacted areas.

The Company will be working closely with MWCC's Career Services Program to utilize its wide range of employee search tools and resources in identifying and supporting the hiring of individuals from disproportionately impacted areas. The Company has made plans to access MWCC's On-Campus Recruiting, Job Fairs, Job Post Board, and assist in the development of its online Career Coach specifically for the cannabis industry. The Company is also planning on hosting a career fair, bi-annually, at its cultivation and product manufacturing facility. These job-specific fairs will include tours of the facility. MWCC staff will work closely with the Company's HR department to ensure the objective of hiring individuals from disproportionately impacted areas is met and data is maintained to track the success of this program.

The Company's first job fair was held on August 27th in Coggshall Park, Fitchburg from 2:30 to 5:00 PM. The job fair was advertised in the Sentinel Newspaper from August 19 thru August 25th, 2019 and was posted on the Market Basket Event Boards at the Central Valley Plaza Shopping Center, 130 Water Street and the Market Basket at Wallace Plaza, 399 John Fitch Highway in Fitchburg. Those who attended the job fair were diverse by ethnicity, race, age, and gender. For qualified candidates, second interviews began immediately after the Labor Day holiday. Additionally, the Company hosted a career fair at its medicinal retail store in Woburn, MA. The job fair took place 06/24/2020 at 130 Commerce Way, Woburn, MA and ran during operational hours. The job fair was advertised on the company's social media platforms as well as in the Lowell Sun Newspaper which encouraged locals to apply for the openings at the Company's retail and production locations. This event was coordinated by the Human Resources Department, Dispensary Coordinator, and the management team in Woburn.

A second job fair was hosted virtually on 09/22/2020 via Indeed where Human Resources conducted interviews with applicants to discuss open job opportunities at Sanctuary. The virtual fair was held to ensure we offered equal opportunity for applicants who may have concerns because of COVID-19. The Company had interviewed 30 applications for positions related to cultivation, post-harvest and retail.

Progress or Success Goal 3

Description of Progress or Success: g. Have in-store donation drives, including direct giving and ongoing food, toiletry, clothing, and monetary donation drives.

The Company's first food drive took place from 08/15 - 09/15/2019 on behalf of the Salvation Army of Fitchburg. Our contact at the Salvation Army in Fitchburg is Deborah (Deb) Andujar of Social Service and she can be reached at deborah.andujar@use.salvationarmy.org. This donation

included 500 food items collected and delivered. As the Company continues to grow, more food drives will be held. Receiving organizations will include Merrimack Valley Food Bank, Open Pantry of Greater Lowell, Highland Baptist Church, and United Neighbors of Fitchburg.

In continuation of our previous donation efforts, the Company held a food drive from 06/26/2020 – 07/10/2020 with the Salvation Army of Fitchburg and collected Dan assortment of food at the Littleton, MA production facility. Products collected during the drive include canned soups, vegetables, boxed pasta, peanut butters, and assorted jam. Our contact at the Salvation Army in Fitchburg is Deborah (Deb) Andujar of Social Service and she can be reached at deborah.andujar@use.salvationarmy.org. As the Company continues to grow, more food drives will be held. A secondary point of contact was Advisory Board Member Paul Gauvin who on Monday 07/20/2020 at 9am accepted the donation at the 739 Water Street location in Fitchburg, MA 01420. Upon completion of the drive our team donated over 500 units of assorted canned and boxed foods that will be used to help feed those who are struggling to have access to food.

A toiletry drive was held from 07/20/2020-08/03/2020 on behalf of the Lowell Transitional Living Center ("LTLC") in Lowell, MA. The LTLC has been actively assisting vulnerable adults in the community to provide housing solutions, meals, and connections to resources and support locally. An assortment of toiletries had been collected from the Littleton, MA production facility including: Masks, Shoe Covers, Toothbrushes, Floss, Razors, Hairbrush, Comb, Hair ties AND Headbands (New), Sunscreen, Travel/Baby Wipes, Diapers, Nail File, Sanitary Pads, Q-tips, Tissues, Toilet Paper, Band-Aids, Baby Powder, Sponges, Dish Detergent. Travel Sized: Hand Sanitizers, Toothpaste, Unscented Lotion, Chapstick, Shaving Cream, Deodorant, Unscented Soap, Shampoo and Conditioner. Our contact at the LTLC is Funmilayo Yusuf, her email is FYusuf@ltlc.org. As of the date over 500 toiletries have been donated to the LTLC on 08/04/2020.

The first big community footprint set by The Company was a clean-up effort located Coggshall Park held in 2019. Coggshall park is a 250-acre recreation area located in Fitchburg Massachusetts. The Company had 30 employee volunteers spend their day in the park helping to clean up the parking lot, gazebo, picnic tables and picnic shelter area. Some team members expanded their efforts to other areas of the park such as the playground and baseball field. During the community cleanup day team members collected garbage and cigarette filters.

In our efforts to remain involved with our communities and help keep them safe and clean The Company participated in a cleanup in Brookline, Massachusetts in the area of Coolidge Corner on July 29, 2020. The Company had a team of 50 Sanctuary employees spend three hours cleaning the Brookline community along Beacon Street. Staff weeded the 9 beds located between Centre and Harvard Street. Teams of 5-6 agents split up between the garden beds and dug holes, planted flowers, provided new topsoil, watered the plants, and mulched. After a day of planting, staff cleaned up the trash in this area and then proceeded to sweep and hose off the sidewalks. After this area was completed pairs of 2 agents spread out to clean up the surrounding neighborhood of litter. The teams collected around 5 bags of trash total and disposed of another 10 which included old soil, roots, and dead plant debris. The team received positive feedback on the newly renovated flower beds from the local community and store owners who passed by and have promised to upkeep the garden beds as our commitment to Brookline.

The Company hosted a community cleanup day where 50 volunteers picked up trash at the Parkhill Park located in the Cleghorn neighborhood of Fitchburg on September 23rd, 2020. The teams set out to clean the park amenities such as the tennis and basketball courts, soccer and football fields, play structure areas, and the parks sub facilities including the Ryan C. Joubert ("RCJ") Memorial Skatepark and the Billie Mundie Baseball Field. The RCJ is New England's Largest skatepark and is made of 13,000 square feet of concrete. The RCJ Memorial Skatepark was created to honor Ryan C. Joubert, a sixteen-year-old Fitchburg High student who died in a car crash on November 7th, 2000. The Sanctuary team spent time cleaning all areas of the park from 12pm-2pm on 09/23/2020 ensuring that the area was safe and clean for the public's enjoyment and use.

The Company partnered with their customers to collect spare change. Each month the Company chose a different local non-profit to contribute donations to. Containers were placed at each retail store and made available for patients/customers/staff to donate to. All donations made by customers were matched by the Company at the end of each month and then donated to the non-profits via a money order check. The non-profits to date include People to People, Youth Villages, HOPE Inc., Mission 22, The Pete Frates Foundation for ALS, Ahimsa Haven Animal Shelter, Lowell Humane Society, Forward in Health, Northeast Arc, and Mission of Deeds and donations total is projected to be between \$7,000-\$10,000 by the end of 2020. Background information on the non-profits in which the Company has chosen are outlined in the document "SMI Store Match Donations - 2020 (2)"

Progress or Success Goal 4

Description of Progress or Success: g(continued). Have in-store donation drives, including direct giving and ongoing food, toiletry, clothing, and monetary donation drives.

On September 12th, 2019 the Melmark New England school received at \$2,500 USD charitable donation to help fund and support the needs of

children and young adults in the Greater Boston Area who have autism, brain injuries, neurological diseases or disorders, and behavioral issues. Their mission is simple, to serve children, adults, and families affected by intellectual disabilities. Following up with our 2019 donation, Sanctuary donated another \$2,500 USD to the Melmark of New England School on September 22nd, 2020.

At the end of October 2019, the Company delivered 100 pumpkins, healthy snacks, beverages and games to the House of Hope. The House of Hope is a homeless shelter for families in Lowell, MA. Our donation was received by Edna Gustafson, the Shelter and Community Services Manager.

The Company donated to the Lowell Firefighters fundraising event for two important charities on September 20th, 2019. This charitable donation went towards the Shriners hospital, a children and family focused hospital that provides high quality care to kids suffering from burn injuries, neuromusculoskeletal conditions, and other ailments that may require special treatment regardless of their race, color, national origin, creed, sex or sect, disability, or ability to pay. The second charity receiving donations during this event was the 911 memorial which is a national museum created in the honor of the 2,983 lives that were lost on September 11, 2001 and February 26, 1993 with the attacks carried out on the World Trade Center.

On 11/27/2019 the Company donated to the Littleton Cancer Drive held by Sandra Santoro who was raising money for her 2-year old daughter who recently had been diagnosed with B-Cell acute lymphoblastic leukemia. Proceeds from the drive were set to be used to support medical bills and bring comfort to the family at a time of need.

On December 17th, 2019 the Company donated \$19,942.50 USD to Justin's Voice, a (501)(c)(3) non-profit helping educate, create awareness, and provide guidance to resources needed to help individuals and their family members get help for drug addiction. This donation was used to install high-tech vape detectors in high school bathrooms and locker rooms. This effort was made to help support the communities chosen by Justin's Voice for the detectors in their preventative action plants to protect underage students from consuming vape products.

In January, the company focused donations on the following groups Gardner Community action Committee, Littleton Police Union, and lastly the Reuben Hoar Library Building Fund. 01/03/2020 a donation was made to the Gardner Community Action Committee (CAC), a non-profit organization whose focus is on economically disadvantaged individuals throughout Gardner, Ashburnham, Baldwinville, Hubbardston, Otter River, Templeton, and Westminster. The Gardner CAC helps to provide services and resources to those who are in need, some efforts include supplying food, clothing, fuel assistance, and medical transportation. To follow the Company donated to the Littleton Police Union on 01/16/2020. The Littleton Police are members of the non-profit organization the Northeastern Massachusetts Law Enforcement Council which focus on sharing resources and preparing for emergencies by offering group support. The final donation for January was to the Reuben Hoar Library Building Fund on 01/21/2020, proceeds were used to help with the construction of the new library in Littleton. The library is projected to be two-levels and be around 23,000 square feet which would include meeting spaces, private study rooms, and an expansion of room to add more books to the library's collection. In addition to our donations, the Company ran a promotion to benefit Rosie's Place in Boston. Rosie's Place is the first women's homeless shelter in the United States. 15% of every sale on an edible or concentrate was donated to Rosie's Place.

Knox Family Foundation received a donation via go-fund-me in April 2020 from the Company. The Knox Family Foundation is a privately run foundation that was created in 1971. Since their start, the foundation has made grants to help organizations in need of support. The Company then sponsored the Brookline Arts Center on 04/27/2020 for their off-the-wall art, donations were used to create awards for the artists. See the link below to explore the talented artwork submitted to this awesome project!

<https://brooklineartscenter.com/events/event-art-off-the-wall-2020-collection/>

To assist the community during the COVID19 Pandemic the Company created and donated hand sanitizer to a local hospital. The receiving hospital was the Heywood Hospital in Gardner, MA. The product was created in the Sanctuary laboratory based on federal guidelines and were delivered during the time of the hand sanitizer shortage.

The Company donated a refrigeration unit from our Sanctuary Gardner, MA location at 16 Pearson Blvd. to the Brookline Food Pantry located at 15 St.Paul Street Brookline, MA 02446. The team loaded the refrigeration unit into one of our volunteer's trucks and transported it to the Brookline Food Pantry who had needed a new unit for their facility. The Brookline Food Pantry works diligently with locals to help supply food and resources to those who are most at need within the community. The donation occurred on August 24th, 2020 and the Brookline Food Pantry will be using it to store perishable foods.

Sanctuary sponsored the MVOC October 22nd, 2020 event held in honor of Jesse H. Stallings, Jr. a veteran of the Army's 101 Airborne who in 1981 took his own life after battling many years of PTSD after the Vietnam war. The event and proceeds raised are used to provide critical services to Veterans and their families local to the Gardner Massachusetts area. Sanctuary contributed a \$1000 bronze level donation on 09/08/2020 which was put toward hosting the virtual event and supporting Veterans and their families.

Progress or Success Goal 5

Description of Progress or Success: g(continued). Have in-store donation drives, including direct giving and ongoing food, toiletry, clothing, and monetary donation drives.

Sanctuary will have nine donation boxes throughout the Brookline facility starting September 2020 with the Muse Foundation and will collect donations for other local non-profit organizations to which the company will match the donation amount collected. Each organization will be asked to provide each sanctuary agents with training on how to speak on behalf of the organizations in a professional and positive manner. The goal is to engage and encourage customers to donate spare change and speak on behalf of the non-profit organization in a way that educates the community members. Upon completion of the donations, Sanctuary Brookline's Community Engagement Manager will deliver the donations and track internal and cumulative donations collected. Donations boxes will be in place on a quarterly basis for Brookline and the money collected at the facility will be dropped off to local non-profit organizations.

Sanctuary Brookline continues to impact the community in a positive way by doing routine clean ups in the local area when business in the store is slow. This helps to keep the teams busy and the community clean and happy. Other ways we have reached out to the community include creating relationships with various hotel concierges in the area to extend invitations to them and their visitors. We have made connections with about 20 hotels and the number continues to grow. Our hopes is to drive traffic not only to our store but to the local businesses in the community of Brookline.

One of World's Largest Puzzles ever assembled was on display at Sanctuary's Beacon Street Art Gallery. In an attempt to bring the community together in a safe manner during the COVID19 Pandemic we worked alongside local business owner David Leschinsky, owner of Eureka! Puzzle & Games to identify ten teams made of 2-4 people to assemble the Ravensburger Puzzle consisting of 40,320 pieces in the comfort of their own homes. Each team was provided with about 4,000 pieces and sent on their way to create their sections. Once each team completed their sections of the project it was then assembled in the Beacon Street Art Gallery and on display for the community to view from the street. Refer to the links below for news coverage as well as the pdf versions

Link: <https://whdh.com/news/brookline-area-households-help-complete-40000-piece-puzzle-while-self-isolating/>

Link: <https://www.masslive.com/boston/2020/09/10-massachusetts-families-put-together-40000-piece-puzzle-of-disney-movie-scenes-while-self-isolating.html>

After the Ravensburger Puzzle was on display a new addition came into the Beacon Street Art Gallery. The exhibit in place is called Prism and explores art that is beautiful, unique, and speaks to each artists style. The artists selected offer diverse pieces of work the represent their artistic techniques utilizing a wide array of colors. The artists currently presenting their art include: Martin Anderson, Suzanne Archibald, Caroline Barnes, John Bassett, Meryl Blinder, Diane Chester-Demicco, Erin Connolly, Molly Dee, Nini Evans, Ruth Ginsberg-Place, Meagan Hepp, Caryl Hull Leavitt, Aja Johnson, Leonie Little-Lex, CJ Lori, Liliana Marquez, Maryellen Moran, Robin Okun, Joseph Perkell, Cary Rapaport, Pamela Roberts, Zoe Schein, and Brianna Whitney.

All of Sanctuary Medicinals locations participated in the Friends of Boston's Homeless Clothing Drive held from October 24th until November 4th, 2020. Donations were collected in Brookline, Danvers, Gardner, Littleton, and Woburn. Collectively the teams were able to contribute a wide array of clothing to the shelter who distributes the donations to other shelters across Massachusetts. Sanctuary staff donated, organized, and sorted through piles of clothing and arranged a delivery to the donation center located at 112 Southampton Street, Boston, MA. Friends of Boston's Homeless supports programs in Boston that are solution-oriented and assist people transitioning from shelters into housing and careers. Donations were delivered on 11/12/2020 and accepted by Ben Williams. Our main points of contact during the drive were Corey Grier the Social Services Administrator for Friends of Boston's Homeless and Mariann Bucina Roca the Executive Director.

Sanctuary Brookline planned and executed a Halloween Bazaar event in the parking lot of the Brookline Teen Center on 10/29/2020. During this

family oriented event staff from Brookline Sanctuary worked and arranged various social distanced games, activities, and food services. For more details on the event please refer to the pdf "Halloween Bazaar 2020 Community Event - Sanctuary Brookline". Halloween may have looked a little different in 2020 but the Sanctuary team was able to create a safe and fun event for all ages.

On 10/31/2020 employees across Sanctuary participated in a costume contest. This contest was not only fun for our staff but also was great for our customers who entered the facilities to see as the theme of this contest was Sanctuary Strains. Employees were asked to dress as their favorite strains and used this opportunity as a fun way to discuss and educate patients and consumers on some of our in house strains.

Sanctuary Brookline has agreed to assist the Brookline Food Pantry with a pie donation estimating \$1000 for the Thanksgiving Holiday. Alongside this effort the Brookline team has offered to lend a helping hand by providing the Food Pantry with staff from Sanctuary around the holiday to volunteer with the Food Pantries needs. In addition the team is currently trying to plan for a canned food drive for later in November or December.

Sanctuary Brookline has taken time over the last few months to write Kindness Cards to be sent to the Presentation Rehabilitation Center located in Brighton, MA. Staff set a goal of writing 100 cards to the residents which were set to include jokes, poems, drawings, and happy messages to brighten their days.

COMPLIANCE WITH DIVERSITY PLAN Diversity Progress or Success 1

Description of Progress or Success: a. Host career fairs in underrepresented and minority communities.

The Company's first job fair was held on August 27th in Coggs Hall Park, Fitchburg from 2:30 to 5:00 PM. The job fair was advertised in the Sentinel Newspaper from August 19 thru August 25th, 2019 and was posted on the Market Basket Event Boards at the Central Valley Plaza Shopping Center, 130 Water Street and the Market Basket at Wallace Plaza, 399 John Fitch Highway in Fitchburg.

Those who attended the job fair were diverse by ethnicity, race, age, and gender. For qualified candidates, second interviews began immediately after the Labor Day holiday.

Additionally, the Company hosted a career fair at its medicinal retail store in Woburn, MA. The job fair took place June 24th, 2020 at 130 Commerce Way, Woburn, MA and ran during operational hours on June 24th, 2020. The job fair was advertised on the company's social media platforms as well as in the Lowell Sun Newspaper. The Lowell Sun Newspaper ad encouraged locals to apply for the openings at the Company's retail and production locations. This event was coordinated by the Human Resources Department, Dispensary Coordinator, and the management team in Woburn.

A second job fair was hosted virtually on 09/22/2020 via Indeed where each department held interviews to discuss open job opportunities at Sanctuary. The virtual fair was held to cater to any concerns that may arise from COVID-19. The Company had 121 reservations a total turnout of 40 attendees for positions related to cultivation, post-harvest and retail.

Sanctuary has already and will continue to be posting jobs opportunities on websites like Blackjobs.com, United Latino Job Bank, LatPro.com, Black Career Network, HBCU Connect, Asian Hires, NAAAP Career Center, iHispano, Diversity Inc., and Diversity Job Board. Additionally and as part of the Company's commitment to meeting its diversity and inclusion objectives in ensuring that we positively impact areas of disproportionate impact, Sanctuary has taken its first steps on ensuring our team is diverse by keeping our promises and continuing to push forward with our efforts.

As part of the Company's employment strategy, we fully embrace the importance of positively impacting areas of disproportionate impact. The Company believes that the best way to delivery these outcomes to those who are underserved is through training, employment and a guided pathway to a long-term career path that offers sustainability and quality of life. Step one was to meet with the Office of Diversity, Inclusion and Community Relations in the Town of Brookline. We have meet multiple times with Director Lloyd Gellineau, and then with Assistant Director Caitlin Starr. They have been instrumental in introducing the Company to resources in the greater Boston area that will help us address our management and well as other hiring needs with Veterans, Women, Blacks, Latinos, Hispanics, Asians, Russian Jews, seniors, the homeless and those with disabilities. We have attached a list of these organizations and the contacts we are currently reaching out to and will continue to contact over the coming weeks and months.

It should also be noted that this is a process that will not have a stop mechanism. It is part of the Company's culture and has been ongoing for our grow facility, currently operating dispensaries and soon to be our Brookline flagship location.

Diversity Progress or Success 2

Description of Progress or Success: b. Specifically, use suppliers who are committed to diversity and inclusion.

The Company foresees significant growth in the consumable category. The Company's primary food vendor Sysco Food Services is highly regarded for its Diversity and Inclusion practices.

Stephen Gould is one of the Company's primary packaging suppliers. They consistently advertise their open employment positions on WorkplaceDiversity.com. WorkplaceDiversity.com is focused on connecting organizations that support and value diversity and inclusion within the workplace.

The Company works with Growershouse to order supplies for the production and cultivation facility. Growershouse is known for their partnerships and discount giveaways with one of the leading CBD companies in the US, Charolettes Web, who recently received certification as a B Corporation. A B Corporation company focuses their efforts on areas outside of profit margins such as community involvement like reducing inequality, lowering poverty levels, creating an environment that is healthy, and creating strong top-quality jobs that have a purpose. The continued goal is to balance profits and purpose. In addition to Growershouse's commitment to external efforts their in-house efforts include supplying first responders and other at-risk communities with thousands of free masks to help combat COVID-19. Sales of KN95 masks are used to support this effort by company matching.

Cintas is a chosen supplier of the Company for our restroom and maintenance supplies. Cintas is known for operating in an ethical manner while maintaining a diverse and inclusive workplace. Cintas believes "There is no place in our country or our company for hatred and discrimination." and Sanctuary supports this message. We believe like Cintas, that equality and justice is for everyone and we both are committed to creating an environment that is safe for our employees to bring different cultures to the table and share their individuality within the company.

Diversity Progress or Success 3

Description of Progress or Success: c. Provide training on recognizing conscious and unconscious bias.

The Company held its first training seminar in recognizing conscious and unconscious bias. Each of the Company's departments met to view two videos on the subject matter. At the conclusion of both videos, an open discussion was conducted with each department by a professional moderator who has expertise in conducting this type of educational seminar on the same informational material, however in the food & beverage industry. A handout on Implicit or Unconscious Bias was created by the Company and was distributed and discussed as part of the seminar.

https://www.youtube.com/watch?v=NW5s_-NI3JE

<https://www.youtube.com/watch?v=rbe5D3Yh43o>

The next training seminar took place in November 2019 and featured the Starbucks unconscious bias training video

<https://news.sky.com/video/starbucks-unconscious-bias-training-video-11388826>

The Company held its second training seminar in recognizing conscious and unconscious bias in each of its facilities to ensure employees are equipped with knowledge and education on how to recognize conscious and unconscious bias in the workplace as well as their personal lives. The training was carried out by our Human Resources Department alongside the company's Operations Department. Content handed out during the seminar was an internal document that employees were encouraged to follow along with. At the completion of the seminar staff was given the floor to ask questions and share any feedback they had. Some team members voluntarily shared stories of past experiences and added that this training was beneficial to have. Teams were trained in a group setting and that handout provided covered the following topics: Overview of Conscious and Unconscious Bias - What is it? Included examples, Where do biases come from and why they occur, Unconscious and Conscious bias based on – Color, Race, Name, Gender, Sexual Preferences, etc., Types of Unconscious and Conscious bias – Halo, Horns, Corporate to customer, Anchoring, etc., Influences in the workplace and decision making – How unconscious bias effects the work environment, Subtle Unconscious Bias, Questions to ask ourselves to increase our understanding and awareness, Behaviors that help achieve a more neutral approach – Self-awareness, cognitive, emotional, and behavioral management, and cultural awareness. Upon completion of the seminar staff

signed off on the training logs and some teams finished their training with a quiz based on the documents used during training.

Diversity Progress or Success 4

Description of Progress or Success: d. Develop relationships with organizations serving minorities, women, people of all gender identities and sexual orientations, Veterans and persons with disabilities for employment referrals.

The Company relationship the Company has established with Mount Wachusett Community College to develop applied-learning, workforce development certificate and micro-credential training programs specifically targeted to minorities, women, people of all gender identities and sexual orientations, veterans and persons with disabilities who are interested in developing career paths in the medicinal and recreational cannabis industry has currently been placed on hold do to the nature of the ongoing safety concerns presented by the COVID-19 pandemic. The demographic profile of the College is ideally suited to address the opportunities for minorities, women, people of all gender identities and sexual orientation, persons with disabilities and is a major resource for veteran services in the New England region but the relationship has since had to part due to the current state of the college and company for safe practices.

Originally as part of the Company's guided pathway for the cannabis industry, once students complete the certificate and micro-credential training programs, they would receive preferential treatment for employment opportunities at the Company's facilities. In addition, with a certificate or micro-credential in cannabis training, new job opportunities would be created for other MA and national cannabis companies. However, this pathway has since been redirected.

With great focus on giving women in the industry the opportunity to pursue and grow a long-term career in the cannabis industry, The Company has worked to ensure Caroline's Cannabis, a woman-owned business, has been given all of the tools they need for ongoing success. Caroline's Cannabis was the first mom and pop cannabis shop in the state that opened in Uxbridge, Massachusetts and was the first female owned to receive their license to operate.

In other efforts to support women outside of the industry, the Company held a toiletry drive for the Lowell Transitional Living Center for homelessness in which the Company stressed the need for women's sanitary products. Shortages in resources often interrupt a woman's daily routine and providing feminine hygiene products to those in need can help bring comfort and peace to them, this was the goal the Company kept in mind when encouraging team members to get involved.

The Company has continued to build our point of contacts in each of our local communities to help broaden and diversify our network. We have chosen to work alongside the New England Veterans Association, ESOL, Rosie's Place, The Asian American Family Network, and Next Steps (BHA Employment Program) to name a few organizations that we have networked with to build a strong relationship and connection. By working with the groups on the Sanctuary Employment Contacts Diversity and Inclusion list we seek to expand and acknowledge the push to create a diversified workforce.

Organizational diversity at Sanctuary refers to the differences in the Company's selected hires. Diversity in the Company is based on age, gender, race, marital status, ethnicity, religion, education, and veteran status. In order to keep a diversified workforce, the Company utilizes the following platforms Diversityjobboard.com, Diversity.com, PDN Recruits, iHispano, Black Career Network, Hispanic/Lation Professionals Association (HLPAs), and Blackjobs.com. Advertisements for positions in general management, assistant management, POS operations, and many more roles alongside our local diversity contacts to welcome people of all walks of life and cultural differences.

Diversity Progress or Success 5

Description of Progress or Success: e. Establish recruitment efforts at higher learning institutions and institutions with programs that reach diverse people.

As stated in the above responses, the Company believes that a combination of hands-on training and guided education and career path efforts will deliver the best opportunities for those diverse populations. The Company made a strategic decision in partnering with MWCC specifically as an educational vehicle to build meaningful cannabis educational programs and to have a direct line to recruitment efforts that reach a cross-section of candidates that make up the college's diverse student body.

The Company's recruitment efforts will be rooted in the paid internships the students will be participating in at the Company. The Company's Department Managers and the Company's Director of HR will constantly monitor the Company's employment needs for job placement opportunities for those students who have participated in the internship program.

Additionally, the Company hosted a career fair at its medicinal retail store in Woburn, MA. The job fair took place 06/24/2020 at 130 Commerce Way, Woburn, MA and ran during operational hours. The job fair was advertised on the company's social media platforms as well as in the Lowell Sun Newspaper which encouraged locals to apply for the openings at the Company's retail and production locations. This event was coordinated by the Human Resources Department, Dispensary Coordinator, and the management team in Woburn. A second job fair is projected to be hosted virtually on 09/22/2020 via Indeed where each department will interview and meet with applicants to discuss open job opportunities at Sanctuary. The virtual fair will be held to cater to any concerns that may arise from COVID-19. The Company expects to have a turnout of 10-25 applications for positions related to cultivation, post harvest and retail.

HOURS OF OPERATION

Monday From: 10:00 AM	Monday To: 8:00 PM
Tuesday From: 10:00 AM	Tuesday To: 8:00 PM
Wednesday From: 10:00 AM	Wednesday To: 8:00 PM
Thursday From: 10:00 AM	Thursday To: 8:00 PM
Friday From: 10:00 AM	Friday To: 8:00 PM
Saturday From: 10:00 AM	Saturday To: 8:00 PM
Sunday From: 10:00 AM	Sunday To: 6:00 PM

Plan to Remain Compliant with Local Zoning

Sanctuary Medicinals, Inc.(Sanctuary) will remain compliant at all times with the local zoning requirements set forth in the Town of Brookline's Zoning Ordinances. The use is allowed by grant of a Special Permit issued by the Town Clerk of the Town of Brookline pursuant to Article #17, Form #2, Submission #2 at the Annual Town Meeting called for Tuesday, May 22, 2018 at 7:00 P.M., adjourned to Thursday, May 24, 2018, at 7:00 P.M., and dissolved on Tuesday, May 29, 2018 at 10:53 P.M. to be permitted in Business Districts: L, G and I. The project is located in zoning District: Business District G. This zoning district allows retail marijuana sales facilities pursuant to the review and requirements of the Special Permit and Site Plan review, noted previously.

Sanctuary Medicinals will comply with applicable State and local laws, regulations, bylaws, codes, conditions and agreements with the Town, including, but not limited to, M.G.L.c. 94G, M.G.L. c. 94I, 935 CMR 500, the Town of Brookline's General By-Laws, the Town of Brookline's Zoning By-Laws, all applicable Town building, fire prevention, police, and health codes, regulations and standards, any conditions imposed on licenses and permits held by the Marijuana Establishment (including, but not limited to, the Town's Zoning Board of Appeals special permit), and agreements between the Marijuana Establishment and the Town, including host community agreements.

In compliance with 935 CMR 500.110(3), the property is not located within 500 feet of an existing public or private school providing education to children in kindergarten or grades 1 through 12.

Sanctuary has already attended several meetings with various municipal officials and boards to discuss Sanctuary's plans for a proposed marijuana establishment and has executed a Host Community Agreement with the Town of Brookline. Sanctuary will continue to work cooperatively with various municipal departments, boards, and officials to ensure that Sanctuary's marijuana establishment remains compliant with all local laws, regulations, rules, and codes with respect to design, construction, operation, and security.

Sanctuary has also retained the law firm Vicente Sederberg LLC to assist with ongoing compliance with local zoning requirements.

Community Outreach Meeting Attestation Form

The applicant must complete each section of this form and initial each page before uploading it to the application. Failure to complete a section will result in the application being deemed incomplete. Instructions to the applicant appear in italics. Please note that submission of information that is “misleading, incorrect, false, or fraudulent” is grounds for denial of an application for a license pursuant to 935 CMR 500.400(1).

I, Jason Sidman, (*insert name*) attest as an authorized representative of Sanctuary Medicinals (*insert name of applicant*) that the applicant has complied with the requirements of 935 CMR 500 and the guidance for licensed applicants on community outreach, as detailed below.

1. The Community Outreach Meeting was held on October 4, 2018 (*insert date*).
2. A copy of a notice of the time, place, and subject matter of the meeting, including the proposed address of the Marijuana Establishment, was published in a newspaper of general circulation in the city or town on September 20, 2018 (*insert date*), which was at least seven calendar days prior to the meeting. A copy of the newspaper notice is attached as Attachment A (*please clearly label the newspaper notice in the upper right hand corner as Attachment A and upload it as part of this document*).
3. A copy of the meeting notice was also filed on September 13, 2018 (*insert date*) with the city or town clerk, the planning board, the contracting authority for the municipality, and local licensing authority for the adult use of marijuana, if applicable. A copy of the municipal notice is attached as Attachment B (*please clearly label the municipal notice in the upper right-hand corner as Attachment B and upload it as part of this document*).
4. Notice of the time, place and subject matter of the meeting, including the proposed address of the Marijuana Establishment, was mailed on September 12, 2018 (*insert date*), which was at least seven calendar days prior to the community outreach meeting to abutters of the proposed address of the Marijuana Establishment, and residents within 300 feet of the property line of the petitioner as they appear on the most recent applicable tax list, notwithstanding that the land of any such owner is located in another city or town. A copy of one of the notices sent to abutters and parties of interest as described in this section is attached as Attachment C (*please clearly label the municipal notice in the upper right hand corner as Attachment C and upload it as part of this document; please only include a copy of one notice and please black out the name and the address of the addressee*).

5. Information was presented at the community outreach meeting including:
 - a. The type(s) of Marijuana Establishment to be located at the proposed address;
 - b. Information adequate to demonstrate that the location will be maintained securely;
 - c. Steps to be taken by the Marijuana Establishment to prevent diversion to minors;
 - d. A plan by the Marijuana Establishment to positively impact the community; and
 - e. Information adequate to demonstrate that the location will not constitute a nuisance as defined by law.

6. Community members were permitted to ask questions and receive answers from representatives of the Marijuana Establishment.

SANCTUARY MEDICINALS, INC.
LEGAL NOTICE
OF COMMUNITY OUTREACH
MEETING
ON OCTOBER 4, 2018 FOR
MARIJUANA ESTABLISHMENTS
PURSUANT TO 935 CMR 500.000

TO: All Abutters to 1351 Beacon St.
Brookline, MA 02446, all residents
within 300 feet of 1351 Beacon St.
Brookline, MA 02446, and other inter-
ested residents or parties.

FROM: Sanctuary Medicinals, Inc.

**SUBJECT OF COMMUNITY OUT-
REACH MEETING:** The Information
presented at the Community Outreach
Meeting will include 1) that the type of
Marijuana Establishment to be located
at 1351 Beacon St, Brookline, MA
02446 is a "Marijuana Retailer"; 2)
information adequate to demonstrate
that the Location will be maintained
securely, and steps to be taken by the
applicant to prevent diversion to
minors; 3) a plan by the applicant to
positively impact the community; and
4) information adequate to demon-
strate that the location will not consti-
tute a nuisance.

Sanctuary will introduce the proposal,
will solicit questions and comments
from the public and will answer any
such questions.

**Date and time of Community
Outreach Meeting: October 4, 2018
at 6:00 pm**

**Location of Meeting: Holiday Inn
Brookline-Boston, 1200 Beacon St,
Brookline, MA, 02446 in the Whitney
A Room.**

If you have any questions regarding
the Community Outreach Meeting,
please contact Josh Weaver, 234
Taylor Street, Littleton, MA 01460;
Phone: 646-573-3462; Email:
jweaver@sanctuarymed.com

AD#13727082
Brookline Tab 9/20/18

Attachment B



Subject **Legal Notice - October 4, 2018 - Sanctuary Medicinals
Community Outreach Meeting**

From <jweaver@sanctuarymed.com>

To <aclark2@brooklinema.gov>, <tjohnson@brooklinema.gov>,
<kbrewton@brooklinema.gov>

Cc Jason Sidman Email <jsidman@sanctuarymed.com>, Jalex
<jalex@sanctuarymed.com>, Joseph A. Giannino
<jgiannino@governmentrelationsgroup.com>, Mallen
<mallen@sanctuarymed.com>, <dshibley@sanctuarymed.com>

Date 2018-09-13 09:24 AM

- LEGAL NOTICE - 1351 Beacon St, Brookline, MA 02446.pdf (~64 KB)

Hello Everyone,

Attached please find the respective Legal Notice of Sanctuary Medicinals Community Outreach Meeting to be held on October 4, 2018. All abutters and residents within 300 feet have been mailed the Notice.

Additionally, The Brookline Tab has been contacted and will be posting the Legal Notice in the 9/20/18 version of the newspaper.

Please let us know if you have any questions.

Thank you,

Josh Weaver
Sanctuary Medicinals, Inc.

Attachment B
roundcube 

Subject **Legal Notice - October 4, 2018 - Sanctuary Medicinals
Community Outreach Meeting**
From <jweaver@sanctuarymed.com>
To <pward@brooklinema.gov>
Cc Jason Sidman Email <jsidman@sanctuarymed.com>, Jalex
<jalex@sanctuarymed.com>, Joseph A. Giannino
<jgiannino@governmentrelationsgroup.com>
Date 2018-09-13 09:21 AM

- LEGAL NOTICE - 1351 Beacon St, Brookline, MA 02446.pdf (~64 KB)

Hello Patrick,

Attached please find the respective Legal Notice of Sanctuary Medicinals Community Outreach Meeting to be held on October 4, 2018. All abutters and residents within 300 feet have been mailed the Notice.

Additionally, The Brookline Tab has been contacted and will be posting the Legal Notice in the 9/20/18 version of the newspaper.

Please let us know if you have any questions.

Thank you,

Josh Weaver
Sanctuary Medicinals, Inc.

Subject **Legal Notice - October 4, 2018 - Sanctuary Medicinals
Community Outreach Meeting**
From <jweaver@sanctuarymed.com>
To <kmartin@brooklinema.gov>, <pseikoe@brooklinema.gov>
Cc Jason Sidman Email <jsidman@sanctuarymed.com>, Jalex
<jalex@sanctuarymed.com>, Joseph A. Giannino
<jgiannino@governmentrelationsgroup.com>
Date 2018-09-13 09:19 AM

Attachment B
roundcube 

- LEGAL NOTICE - 1351 Beacon St, Brookline, MA 02446.pdf (~64 KB)

Hello Polly and Karen,

Attached please find the respective Legal Notice of Sanctuary Medicinals Community Outreach Meeting to be held on October 4, 2018. All abutters and residents within 300 feet have been mailed the Notice.

Additionally, The Brookline Tab has been contacted and will be posting the Legal Notice in the 9/20/18 version of the newspaper.

Please let us know if you have any questions.

Thank you,

Josh Weaver
Sanctuary Medicinals, Inc.

LEGAL NOTICE OF
COMMUNITY OUTREACH MEETING
ON OCTOBER 4, 2018 FOR MARIJUANA ESTABLISHMENTS
PURSUANT TO 935 CMR 500.000

TO: All Abutters to 1351 Beacon St, Brookline, MA 02446, all residents within 300 feet of 1351 Beacon St, Brookline, MA 02446, and other interested residents or parties.

FROM: Sanctuary Medicinals, Inc.

SUBJECT OF COMMUNITY OUTREACH MEETING: The Information presented at the Community Outreach Meeting will include 1) that the type of Marijuana Establishment to be located at 1351 Beacon St, Brookline, MA 02446 is a "Marijuana Retailer"; 2) information adequate to demonstrate that the Location will be maintained securely, and steps to be taken by the applicant to prevent diversion to minors; 3) a plan by the applicant to positively impact the community; and 4) information adequate to demonstrate that the location will not constitute a nuisance.

Sanctuary will introduce the proposal, will solicit questions and comments from the public and will answer any such questions.

**Date and time of
Community Outreach
Meeting:**

October 4, 2018 at 6:00 pm

Location of Meeting:

Holiday Inn Brookline-Boston, 1200 Beacon St, Brookline, MA, 02446 in the Whitney A Room.

If you have any questions regarding the Community Outreach Meeting, please contact Josh Weaver, 234 Taylor Street, Littleton, MA 01460; Phone: 646-573-3462;
Email: jweaver@sanctuarymed.com

LEGAL NOTICE OF
COMMUNITY OUTREACH MEETING
ON OCTOBER 4, 2018 FOR MARIJUANA ESTABLISHMENTS
PURSUANT TO 935 CMR 500.000

TO: All Abutters to 1351 Beacon St, Brookline, MA 02446, all residents within 300 feet of 1351 Beacon St, Brookline, MA 02446, and other interested residents or parties.

FROM: Sanctuary Medicinals, Inc.

SUBJECT OF COMMUNITY OUTREACH MEETING: The Information presented at the Community Outreach Meeting will include 1) that the type of Marijuana Establishment to be located at 1351 Beacon St, Brookline, MA 02446 is a "Marijuana Retailer"; 2) information adequate to demonstrate that the Location will be maintained securely, and steps to be taken by the applicant to prevent diversion to minors; 3) a plan by the applicant to positively impact the community; and 4) information adequate to demonstrate that the location will not constitute a nuisance.

Sanctuary will introduce the proposal, will solicit questions and comments from the public and will answer any such questions.

**Date and time of
Community Outreach
Meeting:**

October 4, 2018 at 6:00 pm

Location of Meeting:

**Holiday Inn Brookline-Boston, 1200 Beacon St, Brookline,
MA, 02446 in the Whitney A Room.**

If you have any questions regarding the Community Outreach Meeting, please contact Josh Weaver, 234 Taylor Street, Littleton, MA 01460; Phone: 646-573-3462;
Email: jweaver@sanctuarymed.com

Host Community Agreement Certification Form

The applicant and contracting authority for the host community must complete each section of this form before uploading it to the application. Failure to complete a section will result in the application being deemed incomplete. Instructions to the applicant and/or municipality appear in italics. Please note that submission of information that is “misleading, incorrect, false, or fraudulent” is grounds for denial of an application for a license pursuant to 935 CMR 500.400(1).

Applicant

I, Jason Sidman, (*insert name*) certify as an authorized representative of Sanctuary Medicinals, Inc. (*insert name of applicant*) that the applicant has executed a host community agreement with Town of Brookline (*insert name of host community*) pursuant to G.L.c. 94G § 3(d) on 10/31/2018 (*insert date*).



Signature of Authorized Representative of Applicant

Host Community

I, Melvin Kleckner, (*insert name*) certify that I am the contracting authority or have been duly authorized by the contracting authority for Town of Brookline (*insert name of host community*) to certify that the applicant and Town of Brookline (*insert name of host community*) has executed a host community agreement pursuant to G.L.c. 94G § 3(d) on 10/31/2018 (*insert date*).

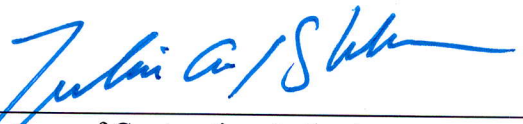

Signature of Contracting Authority or
Authorized Representative of Host Community



Sanctuary Medicinals

234 Taylor Street
Littleton, MA 01460
www.sanctuarymed.com

November 2, 2020

Town of Brookline, MA
Town Administrator
Attn: Mel Kleckner
333 Washington Street
Brookline, MA 012445

Re: Request for Records of Costs Related to Sanctuary Medicinals, Inc. Brookline Operations

Dear Mayor Nicholson:

Please be advised that as conditions of Sanctuary Medicinals, Inc. ("Sanctuary") license renewal approval for its marijuana establishment (ME) in the Town of Brookline ("Brookline" or the "Town"), the Cannabis Control Commission (the "Commission") is requiring Sanctuary to submit, within 90 days of 1/22/21, (1) documentation that it requested from its Host Community the records of any cost to the Town, whether anticipated or actual, resulting from the licensee's operation within its borders, and (2) any response received from the Host Community in connection with such request, and if no response is received, an attestation to that effect.

Accordingly, please accept this correspondence as Sanctuary's formal request to the Town to produce the records of any cost, whether anticipated or actual, resulting from Sanctuary's operation within the Town. Please note that a copy of this correspondence along with any response received by the Town, or barring receipt of any response, an attestation to that effect shall be submitted by Sanctuary to the Commission. As the Town is aware, in accordance with M.G.L. c. 94G, § 3(d), any cost to the Town imposed by the operation of a ME shall be documented and considered a public record as defined by M.G.L. c. 4, § 7, cl. 26.

Sanctuary respectfully requests that the Town respond to this request as soon as possible so that we can timely comply with the conditions of our license renewal.

If we can provide additional information, please do not hesitate to ask.

Sincerely,

Jason Sidman - CEO
Sanctuary Medicinals, Inc.



Sanctuary Medicinals

234 Taylor Street
Littleton, MA 01460
www.sanctuarymed.com

Please be advised that we are waiting on a response from the Town of Brookline in connection with the formal "Request for Records of Costs Related to Operations". We will update the Commission upon receipt. Thank you.

Plan to Positively Impact Areas of Disproportionate Impact

Overview

Sanctuary Medicinals, Inc. (“Sanctuary”) is dedicated to serving and supporting the areas around it, particularly those that are classified as areas of disproportionate impact. Marijuana businesses have an obligation to the health and well-being of their customers as well as the communities that have had historically high rates of arrest, conviction, and incarceration related to marijuana crimes. It is Sanctuary's intention to be a contributing, positive force in areas of disproportionate impact and to assist in changing the perception of those associated with marijuana use.

Sanctuary’s Team

Sanctuary intends to employ individuals, including executives and board members, who reside in areas of disproportionate impact, including Boston. Sanctuary’s team consists of individuals who have previously held positions in organizations that primarily serve areas of disproportionate impact or where primary responsibilities included economic education, resource provision, or empowerment to disproportionately impacted individuals or communities.

As Sanctuary expands, Sanctuary’s goal will be to maintain 20% of individuals that currently reside in an area of disproportionate impact or have lived for five of the preceding ten years in an area of disproportionate impact and will identify individuals who live in Boston. Sanctuary will also strive to maintain a staff comprised of at least 10% of individuals that have a drug-related CORI but are otherwise legally employable in a cannabis-related enterprise. In alignment with Sanctuary’s Diversity Plan, Sanctuary will focus hiring and education efforts on diverse populations including individuals from Black, African American, Hispanic or Latino descent.

Continuing Efforts

To provide continuing service and reinvestment into areas of disproportionate impact, Sanctuary is committed to programming, restorative justice, jail diversion, workforce development, industry-specific technical assistance, and mentoring services in areas of disproportionate impact. Sanctuary is committed to hosting and participating in events that will support areas of disproportionate impact such as community service days, charity events, and educational seminars. Sanctuary will require all executives, managers, and employees to participate quarterly in a community service day. Each community service day will be organized with a charitable or local organization in an area of disproportionate impact. Further plans to positively affect areas of disproportionate impact may include the following:

- Conducting industry-specific educational seminars in one or more of the following: marijuana cultivation, marijuana product manufacturing, marijuana retailing, or marijuana business training;
- Donations to the Social Equity Training and Technical Assistance Fund;

- Providing financial mentoring services or hosting organizations that provide these services (FinLab <http://finlab.cfsinnovation.com/>, Citi Foundation <http://www.citigroup.com/citi/foundation/>, etc.);
- Holding monthly informational sessions regarding the process for sealing and expunging criminal records;
- Partnering with and supporting organizations that provide jail diversion and restorative justice programs;
- Providing transportation support for employees in these areas;
- Instituting hiring practices that prioritize the hiring of individuals from these areas;
- Offering any necessary accommodations to individuals coming from areas of disproportionate impact;
- Having in-store donation drives, including direct giving and ongoing food and clothing drives; and
- Placing donation jars in Sanctuary's facilities where customers can donate directly to the Social Equity Training and Technical Assistance Fund.

Plan Administration

The Chief Operating Officer will administer the Plan to Positively Impact Areas of Disproportionate Impact (the "Plan"). The COO will be responsible for developing measurable outcomes and ensure Sanctuary continues to meet its commitment to the community. The COO will also be responsible for forming philanthropic partnerships in the community to implement and enhance the Plan. The COO will perform quarterly staffing audits to ensure that Sanctuary is meeting its staffing goals for individuals who reside in areas of disproportionate impact located in Boston. In the event that a staffing audit by the COO reveals that Sanctuary has not yet met its objectives, Sanctuary will immediately amend its hiring practices and also make a donation to the Social Equity Training and Technical Assistance Fund to offset any difference.

Furthermore, the Chief Financial Officer will monitor Sanctuary's budget to ensure that there are sufficient funds necessary for the initiatives proposed in Sanctuary's Plan, while also carefully monitoring any and all commitments and donations made to the Social Equity Training and Technical Assistance Fund.



mass.gov/dor

CERTIFICATE OF GOOD STANDING AND/OR TAX COMPLIANCE



SANCTUARY MEDICINALS, INC.
1400 HANCOCK ST FL 3
QUINCY MA 02169-5233

Why did I receive this notice?

The Commissioner of Revenue certifies that, as of the date of this certificate, SANCTUARY MEDICINALS, INC. is in compliance with its tax obligations under Chapter 62C of the Massachusetts General Laws.

This certificate doesn't certify that the taxpayer is compliant in taxes such as unemployment insurance administered by agencies other than the Department of Revenue, or taxes under any other provisions of law.

This is not a waiver of lien issued under Chapter 62C, section 52 of the Massachusetts General Laws.

What if I have questions?

If you have questions, call us at (617) 887-6367 or toll-free in Massachusetts at (800) 392-6089, Monday through Friday, 8:30 a.m. to 4:30 p.m..

Visit us online!

Visit mass.gov/dor to learn more about Massachusetts tax laws and DOR policies and procedures, including your Taxpayer Bill of Rights, and MassTaxConnect for easy access to your account:

- Review or update your account
- Contact us using e-message
- Sign up for e-billing to save paper
- Make payments or set up autopay

Edward W. Coyle, Jr., Chief
Collections Bureau

D

The Commonwealth of Massachusetts

William Francis Galvin
Secretary of the Commonwealth
One Ashburton Place, Boston, Massachusetts 02108-1512

Articles of Entity Conversion of a Domestic Non-Profit with a Pending Provisional or Final Certification to Dispense Medical Use Marijuana to a Domestic Business Corporation (General Laws Chapter 156D, Section 9.53; 950 CMR 113.30)

Sanctuary Medicinals, Inc. is a registrant
with the Department of Public Health
in accordance with 105 CMR 725.100(C)
as of June 27, 2018.

[Signature]
Elizabeth Chen, PhD
Interim Director
Bureau of Health Care Safety and Quality
Massachusetts Department of Public Health

- (1) Exact name of the non-profit: Sanctuary Medicinals, Inc. 001191104
- (2) A corporate name that satisfies the requirements of G.L. Chapter 156D, Section 4.01:
Sanctuary Medicinals, Inc.
- (3) The plan of entity conversion was duly approved in accordance with the law.
- (4) The following information is required to be included in the articles of organization pursuant to G.L. Chapter 156D, Section 2.02(a) or permitted to be included in the articles pursuant to G.L. Chapter 156D, Section 2.02(b):

ARTICLE I

The exact name of the corporation upon conversion is:

Sanctuary Medicinals, Inc.

ARTICLE II

Unless the articles of organization otherwise provide, all corporations formed pursuant to G.L. Chapter 156D have the purpose of engaging in any lawful business. Please specify if you want a more limited purpose:

The general character of the corporation's business is the manufacture of agricultural products, including medicinal Marijuana and any and all products, services and activities related thereto and to engage in any lawful act or activity for which a corporation may be organized under MA General Laws, Chapter 156D. *and sale*

ARTICLE III

State the total number of shares and par value, * if any, of each class of stock that the corporation is authorized to issue. All corporations must authorize stock. If only one class or series is authorized, it is not necessary to specify any particular designation.

WITHOUT PAR VALUE		WITH PAR VALUE		
TYPE	NUMBER OF SHARES	TYPE	NUMBER OF SHARES	PAR VALUE
		Common	275,000	\$0.001

ARTICLE IV

Prior to the issuance of shares of any class or series, the articles of organization must set forth the preferences, limitations and relative rights of that class or series. The articles may also limit the type or specify the minimum amount of consideration for which shares of any class or series may be issued. Please set forth the preferences, limitations and relative rights of each class or series and, if desired, the required type and minimum amount of consideration to be received.

None.

ARTICLE V

The restrictions, if any, imposed by the articles or organization upon the transfer of shares of any class or series of stock are:

None.

ARTICLE VI

Other lawful provisions, and if there are no such provisions, this article may be left blank.

See attached Addendum.

Note: The preceding six (6) articles are considered to be permanent and may be changed only by filing appropriate articles of amendment.

ADDENDUM TO
ARTICLES OF ENTITY CONVERSION
OF
SANCTUARY MEDICINALS, INC.

ARTICLE VI

1. Authority of directors to create new classes and series of shares. The board of directors, acting without the shareholders, may (a) reclassify any unissued shares of any authorized class or series into one or more existing or new classes or series, and (b) create one or more new classes or series of shares, specifying the number of shares to be included therein, the distinguishing designation thereof and the preferences, limitations and relative rights applicable thereto, provided that the board of directors may not approve an aggregate number of authorized shares of all classes and series which exceeds the total number of authorized shares specified in the Articles of Organization.

2. Minimum number of directors. The board of directors may consist of one or more individuals, notwithstanding the number of shareholders.

3. Personal liability of directors to corporation. No director shall have personal liability to the corporation for monetary damages for breach of his or her fiduciary duty as a director notwithstanding any provision of law imposing such liability, provided that this provision shall not eliminate or limit the liability of a director (a) for any breach of the director's duty of loyalty to the corporation or its shareholders, (b) for acts or omissions not in good faith or which involve intentional misconduct or a knowing violation of law, (c) for improper distributions under Section 6.40 of Chapter 156D of the Massachusetts General Laws, or (d) for any transaction from which the director derived an improper personal benefit.

4. Shareholder vote required to approve matters acted on by shareholders. The affirmative vote of a majority of all the shares in a voting group eligible to vote on a matter shall be sufficient for the approval of the matter, notwithstanding any greater vote on the matter otherwise required by any provision of Chapter 156D of the Massachusetts General Laws.

5. Shareholder action without a meeting by less than unanimous consent. Action required or permitted by Chapter 156D of the Massachusetts General Laws to be taken at a shareholders' meeting may be taken without a meeting by shareholders having not less than the minimum number of votes necessary to take the action at a meeting at which all shareholders entitled to vote on the action are present and voting.

6. Authorization of directors to make, amend or repeal bylaws. The board of directors may make, amend or repeal the bylaws in whole or in part, except with respect to any provision thereof which by virtue of an express provision in Chapter 156D of the Massachusetts General Laws, the Articles of Organization or the bylaws requires action by the shareholders.

ARTICLE VII

The effective date of organization of the corporation is the date and time the articles were received for filing if the articles are not rejected within the time prescribed by law. If a later effective date is desired, specify such date, which may not be later than the 90th day after the articles are received for filing:

ARTICLE VIII

The information contained in this article is not a permanent part of the articles of organization.

- a. The street address of the initial registered office of the corporation in the commonwealth:
c/o Vicente Sederberg LLC, 2 Seaport Lane, Boston, MA 02210
- b. The name of its initial registered agent at its registered office:
Brandon Kurtzman, Esq.
- c. The names and addresses of the individuals who will serve as the initial directors, president, treasurer and secretary of the corporation (an address need not be specified if the business address of the officer or director is the same as the principal office location):

President: Jason Sidman

Treasurer: Jason Sidman

Secretary: Michael Wilmoth

Director(s): David Syrek, Gail Perry Borden, Jason Sidman and Michael Wilmoth

- d. The fiscal year end of the corporation:
December 31
- e. A brief description of the type of business in which the corporation intends to engage:
Manufacture and sale of agricultural products, including medicinal marijuana
- f. The street address of the principal office of the corporation:
234 Taylor Street, Littleton, MA 01460
- g. The street address where the records of the corporation required to be kept in the commonwealth are located is:

234 Taylor Street, Littleton, MA 01460 which is
(number, street, city or town, state, zip code)

- its principal office;
- an office of its transfer agent;
- an office of its secretary/assistant secretary;
- its registered office

Signed by:  (signature of authorized individual)

- Chairman of the board of directors.
- President,
- Other officer,
- Court-appointed fiduciary.

on this 9 day of June, 2018

COMMONWEALTH OF MASSACHUSETTS

3/721257

William Francis Galvin
Secretary of the Commonwealth
One Ashburton Place, Boston, Massachusetts 02108-1512

Articles of Entity Conversion of a
Domestic Non-Profit with a Pending Provisional or
Final Certification to Dispense Medical Use Marijuana
to a Domestic Business Corporation
(General Laws Chapter 156D, Section 9.53; 950 CMR 113.30)

I hereby certify that upon examination of these articles of conversion, duly submitted to me, it appears that the provisions of the General Laws relative thereto have been complied with, and I hereby approve said articles; and the filing fee in the amount of \$ 475 having been paid, said articles are deemed to have been filed with me this 3 day of July, 20 18, at 3:55 a.m./p.m.
time

Effective date: _____
(must be within 90 days of date submitted)

WILLIAM FRANCIS GALVIN
Secretary of the Commonwealth

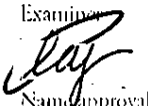

Examiner

Name Approval

Filing fee: Minimum \$250

TO BE FILLED IN BY CORPORATION
Contact Information:

C

M

Michael L. Cifelli c/o Burns & Levinson LLP

125 Summer Street

Boston, MA 02110

Telephone: 617-345-3366

Email: mcifelli@burnslev.com

1313613

Upon filing, a copy of this filing will be available at www.sec.state.ma.us/cor. If the document is rejected, a copy of the rejection sheet and rejected document will be available in the rejected queue.

SECRETARY OF THE COMMONWEALTH
CORPORATIONS DIVISION
2018 JUL -3 PM 3:55

SECOND AMENDED AND RESTATED

BY-LAWS

OF

SANCTUARY MEDICINALS, INC.

(the "Corporation")

ARTICLE I

SHAREHOLDERS

Section 1. Annual Meeting. The Corporation shall hold an annual meeting of shareholders at a time fixed by the Directors. The purposes for which the annual meeting is to be held, in addition to those prescribed by the Articles of Organization, shall be for electing directors and for such other purposes as shall be specified in the notice for the meeting, and only business within such purposes may be conducted at the meeting. In the event an annual meeting is not held at the time fixed in accordance with these By-laws or the time for an annual meeting is not fixed in accordance with these By-laws to be held within 13 months after the last annual meeting was held, the Corporation may designate a special meeting held thereafter as a special meeting in lieu of the annual meeting, and the meeting shall have all of the effect of an annual meeting.

Section 2. Special Meetings. Special meetings of the shareholders may be called by the President or by the Directors, and shall be called by the Secretary, or in case of the death, absence, incapacity or refusal of the Secretary, by another officer, if the holders of at least 10 per cent, or such lesser percentage as the Articles of Organization permit, of all the votes entitled to be cast on any issue to be considered at the proposed special meeting sign, date, and deliver to the Secretary one or more written demands for the meeting describing the purpose for which it is to be held. Only business within the purpose or purposes described in the meeting notice may be conducted at a special shareholders' meeting.

Section 3. Place of Meetings. All meetings of shareholders shall be held at the principal office of the Corporation unless a different place is specified in the notice of the meeting or the meeting is held solely by means of remote communication in accordance with Section 11 of this Article.

Section 4. Requirement of Notice. A written notice of the date, time, and place of each annual and special shareholders' meeting describing the purposes of the meeting shall be given to shareholders entitled to vote at the meeting (and, to the extent required by law or the Articles of Organization, to shareholders not entitled to vote at the meeting) no fewer than seven nor more than 60 days before the meeting date. If an annual or special meeting of shareholders is adjourned to a different date, time or place, notice need not be given of the new date, time or place if the new

date, time or place, if any, is announced at the meeting before adjournment. If a new record date for the adjourned meeting is fixed, however, notice of the adjourned meeting shall be given under this Section to persons who are shareholders as of the new record date. All notices to shareholders shall conform to the requirements of Article III.

Section 5. Waiver of Notice. A shareholder may waive any notice required by law, the Articles of Organization, or these By-laws before or after the date and time stated in the notice. The waiver shall be in writing, be signed by the shareholder entitled to the notice, and be delivered to the Corporation for inclusion with the records of the meeting. A shareholder's attendance at a meeting: (a) waives objection to lack of notice or defective notice of the meeting, unless the shareholder at the beginning of the meeting objects to holding the meeting or transacting business at the meeting; and (b) waives objection to consideration of a particular matter at the meeting that is not within the purpose or purposes described in the meeting notice, unless the shareholder objects to considering the matter when it is presented.

Section 6. Quorum.

(a) Unless otherwise provided by law, or in the Articles of Organization, these By-laws or a resolution of the Directors requiring satisfaction of a greater quorum requirement for any voting group, a majority of the votes entitled to be cast on the matter by a voting group constitutes a quorum of that voting group for action on that matter. As used in these By-laws, a voting group includes all shares of one or more classes or series that, under the Articles of Organization or the Massachusetts Business Corporation Act, as in effect from time to time (the "MBCA"), are entitled to vote and to be counted together collectively on a matter at a meeting of shareholders.

(b) A share once represented for any purpose at a meeting is deemed present for quorum purposes for the remainder of the meeting and for any adjournment of that meeting unless (1) the shareholder attends solely to object to lack of notice, defective notice or the conduct of the meeting on other grounds and does not vote the shares or otherwise consent that they are to be deemed present, or (2) in the case of an adjournment, a new record date is or shall be set for that adjourned meeting.

Section 7. Voting and Proxies. Unless the Articles of Organization provide otherwise, each outstanding share, regardless of class, is entitled to one vote on each matter voted on at a shareholders' meeting. A shareholder may vote his or her shares in person or may appoint a proxy to vote or otherwise act for him or her by signing an appointment form, either personally or by his or her attorney-in-fact. An appointment of a proxy is effective when received by the Secretary or other officer or agent authorized to tabulate votes. Unless otherwise provided in the appointment form, an appointment is valid for a period of 11 months from the date the shareholder signed the form or, if it is undated, from the date of its receipt by the officer or agent. An appointment of a proxy is revocable by the shareholder unless the appointment form conspicuously states that it is irrevocable and the appointment is coupled with an interest, as defined in the MBCA. An appointment made irrevocable is revoked when the interest with which it is coupled is extinguished. The death or incapacity of the shareholder appointing a proxy shall not affect the right of the Corporation to accept the proxy's authority unless notice of the death or incapacity is received by the Secretary or other officer or agent authorized to tabulate votes before the proxy exercises his or her authority under the appointment. A transferee for value of shares subject to

an irrevocable appointment may revoke the appointment if he or she did not know of its existence when he or she acquired the shares and the existence of the irrevocable appointment was not noted conspicuously on the certificate representing the shares or on the information statement for shares without certificates. Subject to the provisions of Section 7.24 of the MBCA and to any express limitation on the proxy's authority appearing on the face of the appointment form, the Corporation is entitled to accept the proxy's vote or other action as that of the shareholder making the appointment.

Section 8. Action at Meeting. If a quorum of a voting group exists, favorable action on a matter, other than the election of Directors, is taken by a voting group if the votes cast within the group favoring the action exceed the votes cast opposing the action, unless a greater number of affirmative votes is required by law, or the Articles of Organization, these By-laws or a resolution of the Board of Directors requiring receipt of a greater affirmative vote of the shareholders, including more separate voting groups. Directors are elected by a plurality of the votes cast by the shares entitled to vote in the election at a meeting at which a quorum is present. No ballot shall be required for such election unless requested by a shareholder present or represented at the meeting and entitled to vote in the election.

Section 9. Action without Meeting by Written Consent.

(a) Action taken at a shareholders' meeting may be taken without a meeting if the action is taken either: (1) by all shareholders entitled to vote on the action; or (2) to the extent permitted by the Articles of Organization, by shareholders having not less than the minimum number of votes necessary to take the action at a meeting at which all shareholders entitled to vote on the action are present and voting. The action shall be evidenced by one or more written consents that describe the action taken, are signed by shareholders having the requisite votes, bear the date of the signatures of such shareholders, and are delivered to the Corporation for inclusion with the records of meetings within 60 days of the earliest dated consent delivered to the Corporation as required by this Section. A consent signed under this Section has the effect of a vote at a meeting.

(b) If action is to be taken pursuant to the consent of voting shareholders without a meeting, the Corporation, at least seven days before the action pursuant to the consent is taken, shall give notice, which complies in form with the requirements of Article III, of the action (1) to nonvoting shareholders in any case where such notice would be required by law if the action were to be taken pursuant to a vote by voting shareholders at a meeting, and (2) if the action is to be taken pursuant to the consent of less than all the shareholders entitled to vote on the matter, to all shareholders entitled to vote who did not consent to the action. The notice shall contain, or be accompanied by, the same material that would have been required by law to be sent to shareholders in or with the notice of a meeting at which the action would have been submitted to the shareholders for approval.

Section 10. Record Date. The Directors may fix the record date in order to determine the shareholders entitled to notice of a shareholders' meeting, to demand a special meeting, to vote, or to take any other action. If a record date for a specific action is not fixed by the Board of Directors, and is not supplied by law, the record date shall be the close of business either on the day before the first notice is sent to shareholders, or, if no notice is sent, on the day before the meeting or, in the case of action without a meeting by written consent, the date the first shareholder signs the

consent. A record date fixed under this Section may not be more than 70 days before the meeting or action requiring a determination of shareholders. A determination of shareholders entitled to notice of or to vote at a shareholders' meeting is effective for any adjournment of the meeting unless the Board of Directors fixes a new record date, which it shall do if the meeting is adjourned to a date more than 120 days after the date fixed for the original meeting.

Section 11. Meetings by Remote Communications. Unless otherwise provided in the Articles of Organization, if authorized by the Directors: any annual or special meeting of shareholders need not be held at any place but may instead be held solely by means of remote communication; and subject to such guidelines and procedures as the Board of Directors may adopt, shareholders and proxyholders not physically present at a meeting of shareholders may, by means of remote communications: (a) participate in a meeting of shareholders; and (b) be deemed present in person and vote at a meeting of shareholders whether such meeting is to be held at a designated place or solely by means of remote communication, provided that: (1) the Corporation shall implement reasonable measures to verify that each person deemed present and permitted to vote at the meeting by means of remote communication is a shareholder or proxyholder; (2) the Corporation shall implement reasonable measures to provide such shareholders and proxyholders a reasonable opportunity to participate in the meeting and to vote on matters submitted to the shareholders, including an opportunity to read or hear the proceedings of the meeting substantially concurrently with such proceedings; and (3) if any shareholder or proxyholder votes or takes other action at the meeting by means of remote communication, a record of such vote or other action shall be maintained by the Corporation.

Section 12. Form of Shareholder Action.

(a) Any vote, consent, waiver, proxy appointment or other action by a shareholder or by the proxy or other agent of any shareholder shall be considered given in writing, dated and signed, if, in lieu of any other means permitted by law, it consists of an electronic transmission that sets forth or is delivered with information from which the Corporation can determine (i) that the electronic transmission was transmitted by the shareholder, proxy or agent or by a person authorized to act for the shareholder, proxy or agent; and (ii) the date on which such shareholder, proxy, agent or authorized person transmitted the electronic transmission. The date on which the electronic transmission is transmitted shall be considered to be the date on which it was signed. The electronic transmission shall be considered received by the Corporation if it has been sent to any address specified by the Corporation for the purpose or, if no address has been specified, to the principal office of the Corporation, addressed to the Secretary or other officer or agent having custody of the records of proceedings of shareholders.

(b) Any copy, facsimile or other reliable reproduction of a vote, consent, waiver, proxy appointment or other action by a shareholder or by the proxy or other agent of any shareholder may be substituted or used in lieu of the original writing for any purpose for which the original writing could be used, but the copy, facsimile or other reproduction shall be a complete reproduction of the entire original writing.

ARTICLE II
DIRECTORS

Section 1. Powers. All corporate power shall be exercised by or under the authority of, and the business and affairs of the Corporation shall be managed under the direction of, its Board of Directors.

Section 2. Number and Election. The Board of Directors shall consist of one or more individuals, with the number fixed by the shareholders at the annual meeting or by the Board of Directors, but, unless otherwise provided in the Articles of Organization, if the Corporation has more than one shareholder, the number of Directors shall not be less than three, except that whenever there shall be only two shareholders, the number of Directors shall not be less than two. Except as otherwise provided in these By-laws or the Articles of Organization, the Directors shall be elected by the shareholders at the annual meeting.

Section 3. Vacancies. If a vacancy occurs on the Board of Directors, including a vacancy resulting from an increase in the number of Directors the Board of Directors may fill the vacancy by the affirmative vote of a majority of all the Directors remaining in office. A vacancy that will occur at a specific later date may be filled before the vacancy occurs but the new Director may not take office until the vacancy occurs.

Section 4. Change in Size of the Board of Directors. The number of Directors may be fixed or changed from time to time by the Board of Directors.

Section 5. Tenure. The terms of all Directors shall expire at the next annual shareholders' meeting following their election. A decrease in the number of Directors does not shorten an incumbent Director's term. The term of a Director elected to fill a vacancy shall expire at the next shareholders' meeting at which Directors are elected. Despite the expiration of a Director's term, he or she shall continue to serve until his or her successor is elected and qualified or until there is a decrease in the number of Directors.

Section 6. Resignation. A Director may resign at any time by delivering written notice of resignation to the Board of Directors, its chairman, or to the Corporation. A resignation is effective when the notice is delivered unless the notice specifies a later effective date.

Section 7. Removal. A Director may be removed from office with or without cause by vote of a majority of the Board then in office. A Director may be removed for cause only after reasonable notice and opportunity to be heard before the Board of Directors.

Section 8. Regular Meetings. Regular meetings of the Board of Directors may be held at such times and places as shall from time to time be fixed by the Board of Directors without notice of the date, time, place or purpose of the meeting.

Section 9. Special Meetings. Special meetings of the Board of Directors may be called by the President, by the Secretary, by any two Directors, or by one Director in the event that there is only one Director.

Section 10. Notice. Special meetings of the Board must be preceded by at least two days' notice of the date, time and place of the meeting. The notice need not describe the purpose of the special meeting. All notices to directors shall conform to the requirements of Article III.

Section 11. Waiver of Notice. A Director may waive any notice before or after the date and time of the meeting. The waiver shall be in writing, signed by the Director entitled to the notice, or in the form of an electronic transmission by the Director to the Corporation, and filed with the minutes or corporate records. A Director's attendance at or participation in a meeting waives any required notice to him or her of the meeting unless the Director at the beginning of the meeting, or promptly upon his or her arrival, objects to holding the meeting or transacting business at the meeting and does not thereafter vote for or assent to action taken at the meeting.

Section 12. Quorum. A quorum of the Board of Directors consists of a majority of the Directors then in office, provided always that any number of Directors (whether one or more and whether or not constituting a quorum) constituting a majority of Directors present at any meeting or at any adjourned meeting may make any reasonable adjournment thereof.

Section 13. Action at Meeting. If a quorum is present when a vote is taken, the affirmative vote of a majority of Directors present is the act of the Board of Directors. A Director who is present at a meeting of the Board of Directors or a committee of the Board of Directors when corporate action is taken is considered to have assented to the action taken unless: (a) he or she objects at the beginning of the meeting, or promptly upon his or her arrival, to holding it or transacting business at the meeting; (b) his or her dissent or abstention from the action taken is entered in the minutes of the meeting; or (c) he or she delivers written notice of his or her dissent or abstention to the presiding officer of the meeting before its adjournment or to the Corporation immediately after adjournment of the meeting. The right of dissent or abstention is not available to a Director who votes in favor of the action taken.

Section 14. Action Without Meeting. Any action required or permitted to be taken by the Directors may be taken without a meeting if the action is taken by the unanimous consent of the members of the Board of Directors. The action must be evidenced by one or more consents describing the action taken, in writing, signed by each Director, or delivered to the Corporation by electronic transmission, to the address specified by the Corporation for the purpose or, if no address has been specified, to the principal office of the Corporation, addressed to the Secretary or other officer or agent having custody of the records of proceedings of Directors, and included in the minutes or filed with the corporate records reflecting the action taken. Action taken under this Section is effective when the last Director signs or delivers the consent, unless the consent specifies a different effective date. A consent signed or delivered under this Section has the effect of a meeting vote and may be described as such in any document.

Section 15. Telephone Conference Meetings. The Board of Directors may permit any or all Directors to participate in a regular or special meeting by, or conduct the meeting through the use of, any means of communication by which all Directors participating may simultaneously hear each other during the meeting. A Director participating in a meeting by this means is considered to be present in person at the meeting.

Section 16. Committees. The Board of Directors may create one or more committees and appoint members of the Board of Directors to serve on them. Each committee may have one or more members, who serve at the pleasure of the Board of Directors. The creation of a committee and appointment of members to it must be approved by a majority of all the Directors in office when the action is taken. Article III and Sections 10 through 15 of this Article shall apply to committees and their members. To the extent specified by the Board of Directors, each committee may exercise the authority of the Board of Directors. A committee may not, however: (a) authorize distributions; (b) approve or propose to shareholders action that the MBCA requires be approved by shareholders; (c) change the number of the Board of Directors, remove Directors from office or fill vacancies on the Board of Directors; (d) amend the Articles of Organization; (e) adopt, amend or repeal By-laws; or (f) authorize or approve reacquisition of shares, except according to a formula or method prescribed by the Board of Directors. The creation of, delegation of authority to, or action by a committee does not alone constitute compliance by a Director with the standards of conduct described in Section 18 of this Article.

Section 17. Compensation. The Board of Directors may fix the compensation of Directors.

Section 18. Standard of Conduct for Directors.

(a) A Director shall discharge his or her duties as a Director, including his or her duties as a member of a committee: (1) in good faith; (2) with the care that a person in a like position would reasonably believe appropriate under similar circumstances; and (3) in a manner the Director reasonably believes to be in the best interests of the Corporation. In determining what the Director reasonably believes to be in the best interests of the Corporation, a Director may consider the interests of the Corporation's employees, suppliers, creditors and customers, the economy of the state, the region and the nation, community and societal considerations, and the long-term and short-term interests of the Corporation and its shareholders, including the possibility that these interests may be best served by the continued independence of the Corporation.

(b) In discharging his or her duties, a Director who does not have knowledge that makes reliance unwarranted is entitled to rely on information, opinions, reports, or statements, including financial statements and other financial data, if prepared or presented by: (1) one or more officers or employees of the Corporation whom the Director reasonably believes to be reliable and competent with respect to the information, opinions, reports or statements presented; (2) legal counsel, public accountants, or other persons retained by the Corporation, as to matters involving skills or expertise the Director reasonably believes are matters (i) within the particular person's professional or expert competence or (ii) as to which the particular person merits confidence; or (3) a committee of the Board of Directors of which the Director is not a member if the Director reasonably believes the committee merits confidence.

(c) A Director is not liable for any action taken as a Director, or any failure to take any action, if he or she performed the duties of his or her office in compliance with this Section.

Section 19. Conflict of Interest.

(a) A conflict of interest transaction is a transaction with the Corporation in which a Director of the Corporation has a material direct or indirect interest. A conflict of interest

transaction is not voidable by the Corporation solely because of the Director's interest in the transaction if any one of the following is true:

(i) the material facts of the transaction and the Director's interest were disclosed or known to the Board of Directors or a committee of the Board of Directors and the Board of Directors or committee authorized, approved, or ratified the transaction;

(ii) the material facts of the transaction and the Director's interest were disclosed or known to the shareholders entitled to vote and they authorized, approved, or ratified the transaction; or

(iii) the transaction was fair to the Corporation.

(b) For purposes of this Section, and without limiting the interests that may create conflict of interest transactions, a Director of the Corporation has an indirect interest in a transaction if: (1) another entity in which he or she has a material financial interest or in which he or she is a general partner is a party to the transaction; or (2) another entity of which he or she is a director, officer, or trustee or in which he or she holds another position is a party to the transaction and the transaction is or should be considered by the Board of Directors of the Corporation.

(c) For purposes of clause (1) of subsection (a), a conflict of interest transaction is authorized, approved, or ratified if it receives the affirmative vote of a majority of the Directors on the Board of Directors (or on the committee) who have no direct or indirect interest in the transaction, but a transaction may not be authorized, approved, or ratified under this Section by a single Director. If a majority of the Directors who have no direct or indirect interest in the transaction vote to authorize, approve, or ratify the transaction, a quorum is present for the purpose of taking action under this Section. The presence of, or a vote cast by, a Director with a direct or indirect interest in the transaction does not affect the validity of any action taken under clause (1) of subsection (a) if the transaction is otherwise authorized, approved, or ratified as provided in that subsection.

(d) For purposes of clause (2) of subsection (a), a conflict of interest transaction is authorized, approved, or ratified if it receives the vote of a majority of the shares entitled to be counted under this subsection. Shares owned by or voted under the control of a Director who has a direct or indirect interest in the transaction, and shares owned by or voted under the control of an entity described in clause (1) of subsection (b), may not be counted in a vote of shareholders to determine whether to authorize, approve, or ratify a conflict of interest transaction under clause (2) of subsection (a). The vote of those shares, however, is counted in determining whether the transaction is approved under other Sections of these By-laws. A majority of the shares, whether or not present, that are entitled to be counted in a vote on the transaction under this subsection constitutes a quorum for the purpose of taking action under this Section.

Section 20. Loans to Directors. The Corporation may not lend money to, or guarantee the obligation of a Director of, the Corporation unless: (a) the specific loan or guarantee is approved by a majority of the votes represented by the outstanding voting shares of all classes, voting as a single voting group, except the votes of shares owned by or voted under the control of the benefited Director; or (b) the Corporation's Board of Directors determines that the loan or guarantee benefits

the Corporation and either approves the specific loan or guarantee or a general plan authorizing loans and guarantees. The fact that a loan or guarantee is made in violation of this Section shall not affect the borrower's liability on the loan.

ARTICLE III

MANNER OF NOTICE

All notices hereunder shall conform to the following requirements:

(a) Notice shall be in writing unless oral notice is reasonable under the circumstances. Notice by electronic transmission is written notice.

(b) Notice may be communicated in person; by telephone, voice mail, telegraph, teletype, or other electronic means; by mail; by electronic transmission; or by messenger or delivery service. If these forms of personal notice are impracticable, notice may be communicated by a newspaper of general circulation in the area where published; or by radio, television, or other form of public broadcast communication.

(c) Written notice, other than notice by electronic transmission, if in a comprehensible form, is effective upon deposit in the United States mail, if mailed postpaid and correctly addressed to the shareholder's address shown in the Corporation's current record of shareholders.

(d) Written notice by electronic transmission, if in comprehensible form, is effective: (1) if by facsimile telecommunication, when directed to a number furnished by the shareholder for the purpose; (2) if by electronic mail, when directed to an electronic mail address furnished by the shareholder for the purpose; (3) if by a posting on an electronic network together with separate notice to the shareholder of such specific posting, directed to an electronic mail address furnished by the shareholder for the purpose, upon the later of (i) such posting and (ii) the giving of such separate notice; and (4) if by any other form of electronic transmission, when directed to the shareholder in such manner as the shareholder shall have specified to the Corporation. An affidavit of the Secretary or an Assistant Secretary of the Corporation, the transfer agent or other agent of the Corporation that the notice has been given by a form of electronic transmission shall, in the absence of fraud, be prima facie evidence of the facts stated therein.

(e) Except as provided in subsection (c), written notice, other than notice by electronic transmission, if in a comprehensible form, is effective at the earliest of the following: (1) when received; (2) five days after its deposit in the United States mail, if mailed postpaid and correctly addressed; (3) on the date shown on the return receipt, if sent by registered or certified mail, return receipt requested; or if sent by messenger or delivery service, on the date shown on the return receipt signed by or on behalf of the addressee; or (4) on the date of publication if notice by publication is permitted.

(f) Oral notice is effective when communicated if communicated in a comprehensible manner.

ARTICLE IV

OFFICERS

Section 1. Enumeration. The Corporation shall have a President, a Treasurer, a Secretary and such other officers as may be appointed by the Board of Directors from time to time in accordance with these By-laws. The Board may appoint one of its members to the office of Chairman of the Board and from time to time define the powers and duties of that office notwithstanding any other provisions of these By-laws.

Section 2. Appointment. The officers shall be appointed by the Board of Directors. A duly appointed officer may appoint one or more officers or assistant officers if authorized by the Board of Directors. Each officer has the authority and shall perform the duties set forth in these By-laws or, to the extent consistent with these By-laws, the duties prescribed by the Board of Directors or by direction of an officer authorized by the Board of Directors to prescribe the duties of other officers.

Section 3. Qualification. The same individual may simultaneously hold more than one office in the Corporation.

Section 4. Tenure. Officers shall hold office until the first meeting of the Directors following the next annual meeting of shareholders after their appointment and until their respective successors are duly appointed, unless a shorter or longer term is specified in the vote appointing them.

Section 5. Resignation. An officer may resign at any time by delivering notice of the resignation to the Corporation. A resignation is effective when the notice is delivered unless the notice specifies a later effective date. If a resignation is made effective at a later date and the Corporation accepts the future effective date, the Board of Directors may fill the pending vacancy before the effective date if the Board of Directors provides that the successor shall not take office until the effective date. An officer's resignation shall not affect the Corporation's contract rights, if any, with the officer.

Section 6. Removal. The Board of Directors may remove any officer at any time with or without cause. The appointment of an officer shall not itself create contract rights. An officer's removal shall not affect the officer's contract rights, if any, with the Corporation.

Section 7. President. The President when present shall preside at all meetings of the shareholders and, if there is no Chairman of the Board of Directors, of the Directors. He or she shall be the chief executive officer of the Corporation except as the Board of Directors may otherwise provide. The President shall perform such duties and have such powers additional to the foregoing as the Directors shall designate.

Section 8. Treasurer. The Treasurer shall, subject to the direction of the Directors, have general charge of the financial affairs of the Corporation and shall cause to be kept accurate books of accounts. He or she shall have custody of all funds, securities, and valuable documents of the Corporation, except as the Directors may otherwise provide. The Treasurer shall perform such duties and have such powers additional to the foregoing as the Directors may designate.

Section 9. Secretary. The Secretary shall have responsibility for preparing minutes of the Directors' and shareholders' meetings and for authenticating records of the Corporation. The Secretary shall perform such duties and have such powers additional to the foregoing as the Directors shall designate.

Section 10. Standards Of Conduct For Officers. An officer shall discharge his or her duties: (a) in good faith; (b) with the care that a person in a like position would reasonably exercise under similar circumstances; and (c) in a manner the officer reasonably believes to be in the best interests of the Corporation. In discharging his or her duties, an officer, who does not have knowledge that makes reliance unwarranted, is entitled to rely on information, opinions, reports, or statements, including financial statements and other financial data, if prepared or presented by: (1) one or more officers or employees of the Corporation whom the officer reasonably believes to be reliable and competent with respect to the information, opinions, reports or statements presented; or (2) legal counsel, public accountants, or other persons retained by the Corporation as to matters involving skills or expertise the officer reasonably believes are matters (i) within the particular person's professional or expert competence or (ii) as to which the particular person merits confidence. An officer shall not be liable to the Corporation or its shareholders for any decision to take or not to take any action taken, or any failure to take any action, as an officer, if the duties of the officer are performed in compliance with this Section.

ARTICLE V

PROVISIONS RELATING TO SHARES

Section 1. Issuance and Consideration. The Board of Directors may issue the number of shares of each class or series authorized by the Articles of Organization. The Board of Directors may authorize shares to be issued for consideration consisting of any tangible or intangible property or benefit to the Corporation, including cash, promissory notes, services performed, contracts for services to be performed, or other securities of the Corporation. Before the Corporation issues shares, the Board of Directors shall determine that the consideration received or to be received for shares to be issued is adequate. The Board of Directors shall determine the terms upon which the rights, options, or warrants for the purchase of shares or other securities of the Corporation are issued and the terms, including the consideration, for which the shares or other securities are to be issued.

Section 2. Share Certificates. If shares are represented by certificates, at a minimum each share certificate shall state on its face: (a) the name of the Corporation and that it is organized under the laws of The Commonwealth of Massachusetts; (b) the name of the person to whom issued; and (c) the number and class of shares and the designation of the series, if any, the certificate represents. If different classes of shares or different series within a class are authorized, then the variations in rights, preferences and limitations applicable to each class and series, and the authority of the Board of Directors to determine variations for any future class or series, must be summarized on the front or back of each certificate. Alternatively, each certificate may state conspicuously on its front or back that the Corporation will furnish the shareholder this information on request in writing and without charge. Each share certificate shall be signed, either manually or in facsimile, by the President or a Vice President and by the Treasurer or an Assistant Treasurer, or any two officers designated by the Board of Directors, and shall bear the corporate seal or its

facsimile. If the person who signed, either manually or in facsimile, a share certificate no longer holds office when the certificate is issued, the certificate shall be nevertheless valid.

Section 3. Uncertificated Shares. The Board of Directors may authorize the issue of some or all of the shares of any or all of the Corporation's classes or series without certificates. The authorization shall not affect shares already represented by certificates until they are surrendered to the Corporation. Within a reasonable time after the issue or transfer of shares without certificates, the Corporation shall send the shareholder a written statement of the information required by the MBCA to be on certificates.

Section 4. Record and Beneficial Owners. The Corporation shall be entitled to treat as the shareholder the person in whose name shares are registered in the records of the Corporation or, if the Board of Directors has established a procedure by which the beneficial owner of shares that are registered in the name of a nominee will be recognized by the Corporation as a shareholder, the beneficial owner of shares to the extent of the rights granted by a nominee certificate on file with the Corporation.

Section 5. Lost or Destroyed Certificates. The Board of Directors of the Corporation may, subject to Massachusetts General Laws, Chapter 106, Section 8-405, determine the conditions upon which a new share certificate may be issued in place of any certificate alleged to have been lost, destroyed, or wrongfully taken. The Board of Directors may, in its discretion, require the owner of such share certificate, or his or her legal representative, to give a bond, sufficient in its opinion, with or without surety, to indemnify the Corporation against any loss or claim which may arise by reason of the issue of the new certificate.

Section 6. Restrictions on Transfer.

(a) The shares of the Corporation shall be transferable, so as to affect the rights of the Corporation, only by transfer recorded on the books of the Corporation, in person or by duly authorized attorney, and upon the surrender of the certificate or certificates properly endorsed or assigned.

(b) Except as may be otherwise required by law, the Corporation shall be entitled to treat the record holder of stock as shown on its books as the owner of such stock for all purposes, including the payment of dividends and the right to vote with respect thereto, regardless of any transfer, pledge or other disposition of such stock, until the shares have been transferred on the books of the Corporation in accordance with the requirements of these By-laws. It shall be the duty of each shareholder to notify the Corporation of his or her post office address.

ARTICLE VI

CORPORATE RECORDS

Section 1. Records to be Kept.

(a) The Corporation shall keep as permanent records minutes of all meetings of its shareholders and Board of Directors, a record of all actions taken by the shareholders or Board of

Directors without a meeting, and a record of all actions taken by a committee of the Board of Directors in place of the Board of Directors on behalf of the Corporation. The Corporation shall maintain appropriate accounting records. The Corporation or its agent shall maintain a record of its shareholders, in a form that permits preparation of a list of the names and addresses of all shareholders, in alphabetical order by class of shares showing the number and class of shares held by each. The Corporation shall maintain its records in written form or in another form capable of conversion into written form within a reasonable time.

(b) The Corporation shall keep within The Commonwealth of Massachusetts a copy of the following records at its principal office or an office of its transfer agent or of its Secretary or Assistant Secretary or of its registered agent:

- (i) its Articles of Organization and all amendments to them currently in effect;
- (ii) its By-laws or restated By-laws and all amendments to them currently in effect;
- (iii) resolutions adopted by its Board of Directors creating one or more classes or series of shares, and fixing their relative rights, preferences, and limitations, if shares issued pursuant to those resolutions are outstanding;
- (iv) the minutes of all shareholders' meetings, and records of all action taken by shareholders without a meeting, for the past three years;
- (v) all written communications to shareholders generally within the past three years, including the financial statements furnished under Section 16.20 of the MBCA for the past three years;
- (vi) a list of the names and business addresses of its current Directors and officers; and
- (vii) its most recent annual report delivered to the Massachusetts Secretary of State.

Section 2. Inspection of Records by Shareholders.

(a) A shareholder is entitled to inspect and copy, during regular business hours at the office where they are maintained pursuant to Section 1(b) of this Article, copies of any of the records of the Corporation described in said Section if he or she gives the Corporation written notice of his or her demand at least five business days before the date on which he or she wishes to inspect and copy.

(b) A shareholder is entitled to inspect and copy, during regular business hours at a reasonable location specified by the Corporation, any of the following records of the Corporation if the shareholder meets the requirements of subsection (c) and gives the Corporation written notice of his or her demand at least five business days before the date on which he or she wishes to inspect and copy:

(i) excerpts from minutes reflecting action taken at any meeting of the Board of Directors, records of any action of a committee of the Board of Directors while acting in place of the Board of Directors on behalf of the Corporation, minutes of any meeting of the shareholders, and records of action taken by the shareholders or Board of Directors without a meeting, to the extent not subject to inspection under subsection (a) of this Section;

(ii) accounting records of the Corporation, but if the financial statements of the Corporation are audited by a certified public accountant, inspection shall be limited to the financial statements and the supporting schedules reasonably necessary to verify any line item on those statements; and

(iii) the record of shareholders described in Section 1(a) of this Article.

(c) A shareholder may inspect and copy the records described in subsection (b) only if:

(i) his or her demand is made in good faith and for a proper purpose;

(ii) he or she describes with reasonable particularity his or her purpose and the records he or she desires to inspect;

(iii) the records are directly connected with his or her purpose; and

(iv) the Corporation shall not have determined in good faith that disclosure of the records sought would adversely affect the Corporation in the conduct of its business.

(d) For purposes of this Section, "shareholder" includes a beneficial owner whose shares are held in a voting trust or by a nominee on his or her behalf.

Section 3. Scope of Inspection Right.

(a) A shareholder's agent or attorney has the same inspection and copying rights as the shareholder represented.

(b) The Corporation may, if reasonable, satisfy the right of a shareholder to copy records under Section 2 of this Article by furnishing to the shareholder copies by photocopy or other means chosen by the Corporation including copies furnished through an electronic transmission.

(c) The Corporation may impose a reasonable charge, covering the costs of labor, material, transmission and delivery, for copies of any documents provided to the shareholder. The charge may not exceed the estimated cost of production, reproduction, transmission or delivery of the records.

(d) The Corporation may comply at its expense, with a shareholder's demand to inspect the record of shareholders under Section 2(b)(3) of this Article by providing the shareholder with a list of shareholders that was compiled no earlier than the date of the shareholder's demand.

(e) The Corporation may impose reasonable restrictions on the use or distribution of records by the demanding shareholder.

Section 4. Inspection of Records by Directors. A Director is entitled to inspect and copy the books, records and documents of the Corporation at any reasonable time to the extent reasonably related to the performance of the Director's duties as a Director, including duties as a member of a committee, but not for any other purpose or in any manner that would violate any duty to the Corporation.

ARTICLE VII

INDEMNIFICATION

Section 1. Definitions. In this Article the following words shall have the following meanings unless the context requires otherwise:

"Corporation", includes any domestic or foreign predecessor entity of the Corporation in a merger.

"Director" or "officer", an individual who is or was a Director or officer, respectively, of the Corporation or who, while a Director or officer of the Corporation, is or was serving at the Corporation's request as a director, officer, partner, trustee, employee, or agent of another domestic or foreign corporation, partnership, joint venture, trust, employee benefit plan, or other entity. A Director or officer is considered to be serving an employee benefit plan at the Corporation's request if his or her duties to the Corporation also impose duties on, or otherwise involve services by, him or her to the plan or to participants in or beneficiaries of the plan. "Director" or "officer" includes, unless the context requires otherwise, the estate or personal representative of a Director or officer.

"Disinterested Director", a Director who, at the time of a vote or selection referred to in Section 4 of this Article, is not (i) a party to the proceeding, or (ii) an individual having a familial, financial, professional, or employment relationship with the Director whose indemnification or advance for expenses is the subject of the decision being made, which relationship would, in the circumstances, reasonably be expected to exert an influence on the Director's judgment when voting on the decision being made.

"Expenses", includes counsel fees.

"Liability", the obligation to pay a judgment, settlement, penalty, fine including an excise tax assessed with respect to an employee benefit plan, or reasonable expenses incurred with respect to a proceeding.

"Party", an individual who was, is, or is threatened to be made, a defendant or respondent in a proceeding.

"Proceeding", any threatened, pending, or completed action, suit, or proceeding, whether civil, criminal, administrative, arbitative, or investigative and whether formal or informal.

Section 2. Indemnification of Directors and Officers.

(a) Except as otherwise provided in this Section, the Corporation shall indemnify to the fullest extent permitted by law an individual who is a party to a proceeding because he or she is a Director or officer against liability incurred in the proceeding if: (1) (i) he or she conducted himself or herself in good faith; and (ii) he or she reasonably believed that his or her conduct was in the best interests of the Corporation or that his or her conduct was at least not opposed to the best interests of the Corporation; and (iii) in the case of any criminal proceeding, he or she had no reasonable cause to believe his or her conduct was unlawful; or (2) he or she engaged in conduct for which he or she shall not be liable under a provision of the Articles of Organization authorized by Section 2.02(b)(4) of the MBCA or any successor provision to such Section.

(b) A Director's or officer's conduct with respect to an employee benefit plan for a purpose he or she reasonably believed to be in the interests of the participants in, and the beneficiaries of, the plan is conduct that satisfies the requirement that his or her conduct was at least not opposed to the best interests of the Corporation.

(c) The termination of a proceeding by judgment, order, settlement, or conviction, or upon a plea of nolo contendere or its equivalent, is not, of itself, determinative that the Director or officer did not meet the relevant standard of conduct described in this Section.

(d) Unless ordered by a court, the Corporation may not indemnify a Director or officer under this Section if his or her conduct did not satisfy the standards set forth in subsection (a) or subsection (b).

Section 3. Advance for Expenses. The Corporation shall, before final disposition of a proceeding, advance funds to pay for or reimburse the reasonable expenses incurred by a Director or officer who is a party to a proceeding because he or she is a Director or officer if he or she delivers to the Corporation:

(a) a written affirmation of his or her good faith belief that he or she has met the relevant standard of conduct described in Section 2 of this Article or that the proceeding involves conduct for which liability has been eliminated under a provision of the Articles of Organization as authorized by Section 2.02(b)(4) of the MBCA or any successor provision to such Section; and

(b) his or her written undertaking to repay any funds advanced if he or she is not wholly successful, on the merits or otherwise, in the defense of such proceeding and it is ultimately determined pursuant to Section 4 of this Article or by a court of competent jurisdiction that he or she has not met the relevant standard of conduct described in Section 2 of this Article. Such undertaking must be an unlimited general obligation of the Director or officer but need not be secured and shall be accepted without reference to the financial ability of the Director or officer to make repayment.

Section 4. Determination of Indemnification. The determination of whether a Director officer has met the relevant standard of conduct set forth in Section 2 shall be made:

(a) if there are two or more disinterested Directors, by the Board of Directors by a majority vote of all the disinterested Directors, a majority of whom shall for such purpose constitute a quorum, or by a majority of the members of a committee of two or more disinterested Directors appointed by vote;

(b) by special legal counsel (1) selected in the manner prescribed in clause (a); or (2) if there are fewer than two disinterested Directors, selected by the Board of Directors, in which selection Directors who do not qualify as disinterested Directors may participate; or

(c) by the shareholders, but shares owned by or voted under the control of a Director who at the time does not qualify as a disinterested Director may not be voted on the determination.

Section 5. Notification and Defense of Claim; Settlements.

(a) In addition to and without limiting the foregoing provisions of this Article and except to the extent otherwise required by law, it shall be a condition of the Corporation's obligation to indemnify under Section 2 of this Article (in addition to any other condition provide in these By-laws or by law) that the person asserting, or proposing to assert, the right to be indemnified, must notify the Corporation in writing as soon as practicable of any action, suit, proceeding or investigation involving such person for which indemnity will or could be sought, but the failure to so notify shall not affect the Corporation's objection to indemnify except to the extent the Corporation is adversely affected thereby. With respect to any proceeding of which the Corporation is so notified, the Corporation will be entitled to participate therein at its own expense and/or to assume the defense thereof at its own expense, with legal counsel reasonably acceptable to such person. After notice from the Corporation to such person of its election so to assume such defense, the Corporation shall not be liable to such person for any legal or other expenses subsequently incurred by such person in connection with such action, suit, proceeding or investigation other than as provided below in this subsection (a). Such person shall have the right to employ his or her own counsel in connection with such action, suit, proceeding or investigation, but the fees and expenses of such counsel incurred after notice from the Corporation of its assumption of the defense thereof shall be at the expense of such person unless (1) the employment of counsel by such person has been authorized by the Corporation, (2) counsel to such person shall have reasonably concluded that there may be a conflict of interest or position on any significant issue between the Corporation and such person in the conduct of the defense of such action, suit, proceeding or investigation or (3) the Corporation shall not in fact have employed counsel to assume the defense of such action, suit, proceeding or investigation, in each of which cases the fees and expenses of counsel for such person shall be at the expense of the Corporation, except as otherwise expressly provided by this Article. The Corporation shall not be entitled, without the consent of such person, to assume the defense of any claim brought by or in the right of the Corporation or as to which counsel for such person shall have reasonably made the conclusion provided for in clause (2) above.

(b) The Corporation shall not be required to indemnify such person under this Article for any amounts paid in settlement of any proceeding unless authorized in the same manner as the determination that indemnification is permissible under Section 4 of this Article, except that if there are fewer than two disinterested Directors, authorization of indemnification shall be made by the Board of Directors, in which authorization Directors who do not qualify as disinterested Directors may participate. The Corporation shall not settle any action, suit, proceeding or investigation in any manner which would impose any penalty or limitation on such person without such person's written consent. Neither the Corporation nor such person will unreasonably withhold their consent to any proposed settlement.

Section 6. Insurance. The Corporation may purchase and maintain insurance on behalf of an individual who is a Director or officer of the Corporation, or who, while a Director or officer of the Corporation, serves at the Corporation's request as a director, officer, partner, trustee, employee, or agent of another domestic or foreign corporation, partnership, joint venture, trust, employee benefit plan, or other entity, against liability asserted against or incurred by him or her in that capacity or arising from his or her status as a Director or officer, whether or not the Corporation would have power to indemnify or advance expenses to him or her against the same liability under this Article.

Section 7. Application of this Article.

(a) The Corporation shall not be obligated to indemnify or advance expenses to a Director or officer of a predecessor of the Corporation, pertaining to conduct with respect to the predecessor, unless otherwise specifically provided.

(b) This Article shall not limit the Corporation's power to (1) pay or reimburse expenses incurred by a Director or an officer in connection with his or her appearance as a witness in a proceeding at a time when he or she is not a party or (2) indemnify, advance expenses to or provide or maintain insurance on behalf of an employee or agent.

(c) The indemnification and advancement of expenses provided by, or granted pursuant to, this Article shall not be considered exclusive of any other rights to which those seeking indemnification or advancement of expenses may be entitled.

(d) Each person who is or becomes a Director or officer shall be deemed to have served or to have continued to serve in such capacity in reliance upon the indemnity provided for in this Article. All rights to indemnification under this Article shall be deemed to be provided by a contract between the Corporation and the person who serves as a Director or officer of the Corporation at any time while these By-laws and the relevant provisions of the MBCA are in effect. Any repeal or modification thereof shall not affect any rights or obligations then existing.

(e) If the laws of the Commonwealth of Massachusetts are hereafter amended from time to time to increase the scope of permitted indemnification, indemnification hereunder shall be provided to the fullest extent permitted or required by any such amendment.

ARTICLE VIII

FISCAL YEAR

The fiscal year of the Corporation shall end on December 31 in each year.

ARTICLE IX

AMENDMENTS

(a) The Board of Directors may make, amend or repeal these By-laws in whole or in part, except with respect to any provision thereof which by virtue of an express provision in the MBCA, the Articles of Organization, or these By-laws, requires action by the shareholders.

(b) Not later than the time of giving notice of the meeting of shareholders next following the making, amending or repealing by the Board of Directors of any By-Law, notice stating the substance of the action taken by the Board of Directors shall be given to all shareholders entitled to vote on amending the By-laws. Any action taken by the Board of Directors with respect to the By-laws may be amended or repealed by the shareholders.

(c) Approval of an amendment to the By-laws that changes or deletes a quorum or voting requirement for action by shareholders must satisfy both the applicable quorum and voting requirements for action by shareholders with respect to amendment of these By-laws and also the particular quorum and voting requirements sought to be changed or deleted.

(d) A By-Law dealing with quorum or voting requirements for shareholders, including additional voting groups, may not be adopted, amended or repealed by the Board of Directors.

(e) A By-Law that fixes a greater or lesser quorum requirement for action by the Board of Directors, or a greater voting requirement, than provided for by the MBCA may be amended or repealed by the shareholders, or by the Board of Directors if authorized pursuant to subsection (a).

(f) If the Board of Directors is authorized to amend the By-laws, approval by the Board of Directors of an amendment to the By-laws that changes or deletes a quorum or voting requirement for action by the Board of Directors must satisfy both the applicable quorum and voting requirements for action by the Board of Directors with respect to amendment of the By-laws, and also the particular quorum and voting requirements sought to be changed or deleted.

4830-3670-2060.1

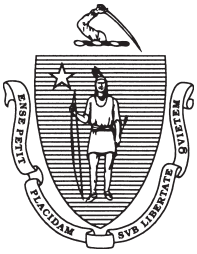

The Commonwealth of Massachusetts
Secretary of the Commonwealth
State House, Boston, Massachusetts 02133

William Francis Galvin
Secretary of the
Commonwealth

Date: July 05, 2018

To Whom It May Concern :

I hereby certify that according to the records of this office,

SANCTUARY MEDICINALS, INC.

is a domestic corporation organized on **July 03, 2018** , under the General Laws of the Commonwealth of Massachusetts. I further certify that there are no proceedings presently pending under the Massachusetts General Laws Chapter 156D section 14.21 for said corporation's dissolution; that articles of dissolution have not been filed by said corporation; that, said corporation has filed all annual reports, and paid all fees with respect to such reports, and so far as appears of record said corporation has legal existence and is in good standing with this office.



In testimony of which,

I have hereunto affixed the

Great Seal of the Commonwealth

on the date first above written.

A handwritten signature in black ink that reads "William Francis Galvin".

Secretary of the Commonwealth

Certificate Number: 18070076120

Verify this Certificate at: <http://corp.sec.state.ma.us/CorpWeb/Certificates/Verify.aspx>

Processed by:

Plan for Obtaining Liability Insurance

Sanctuary Medicinals, LLC (“Sanctuary”) plans to contract with Next Wave to maintain general liability insurance coverage for no less than \$1,000,000 per occurrence and \$2,000,000 in aggregate annually and product liability coverage for no less than \$1,000,000 per occurrence & \$2,000,000 in aggregate annually. The policy deductible will be no higher than \$5,000 per occurrence. Sanctuary will consider additional coverage based on availability & cost-benefit analysis. If adequate coverage is unavailable at a reasonable rate, Sanctuary will place in escrow at least \$250,000 to be expended for liabilities coverage. Any withdrawal from such escrow replenished within 10 business days. Sanctuary will keep reports documenting compliance with 935 CMR 500.105(10).

WELCOME TO SANCTUARY MEDICINALS

Our mission is simple:

To provide the highest quality organic medicine, service, education and experience to qualified Massachusetts registered marijuana patients and adult-use consumers.

We are a compassionate group who believe that this goal can only be accomplished through a caring, trusting and knowledgeable approach focused on a patient's specific medical condition and financial availability.

...A true sanctuary, free from harm, judgment and prejudice.

COMPANY SUMMARY

Sanctuary Medicinals LLC was formed to run both licensed Registered Marijuana Dispensary (RMD) and Licensed Marijuana Establishments in the State of Massachusetts.

Our executive team bring expertise and backgrounds in licensed marijuana dispensing / cultivating, business management, capital markets, organic farming, law enforcement, litigation/lobbying, and medical expertise. The unique combination of medical professionals, law enforcement, business management, and experience with horticulture and organic marijuana cultivating makes our team an ideal fit for the Massachusetts medical marijuana program.

As a licensed Registered Marijuana Dispensary and Licensed Marijuana Establishment, we will bring the Massachusetts's medical marijuana community and adult-use consumers a variety of medical marijuana products and services. This includes marijuana flower, concentrates, edibles, topics, and educational literature. The extended experience of our management team along with our previous licensed marijuana dispensing / cultivating facilities gives us an extensive familiarity in the cultivation, processing, and distribution of medical marijuana products. We are very familiar with all products and processes, and look forward to having the opportunity to bring this experience and knowledge to Massachusetts's medical marijuana program.

Having offered the services presented in New Hampshire, we understand the multitude of risks associated with running a successful medical marijuana organization. These include security risks, cultivation risks related to crop failures and failing test results, financing risk due to the capital intensive nature of these operations, and regulatory risk pending future regulations at the State and Federal level.

As an organization, we will be heavily focused on charitable activities that help support our cause to bring quality alternative medicine to patients in the State of Massachusetts. These include patient assistance programs, community outreach programs, and various charitable donations. All will be in the interest of educating and supporting Massachusetts's medical marijuana community.

EXECUTIVE TEAM

CEO – JASON A. SIDMAN

COO- JAMES ALEX

CFO – JOSH WEAVER

Jason A. Sidman, CEO

Mr. Sidman earned his bachelor of science from the Whittemore School of Business at the University of New Hampshire in 2001 while graduating in the top of the class. His senior year he participated in a pilot program at Fidelity Investments, which he continued through graduation. This enabled Mr. Sidman to receive extensive training in regulatory compliance, taxation and capital markets. This experience provided the foundation to start PTG Capital in March of 2002, a self-funded equity firm where he assumed the position of CEO. PTG Capital started with five traders executing a million shares daily on the NYSE. His extensive insight of capital markets and strong leadership provided the underpinning for explosive growth. Within three years of operations PTG Capital grew to five offices with over seventy traders, trading funds in excess of one hundred million while executing five million shares daily.

Jason Sidman is a founding member of Sanctuary ATC and Sanctuary Medicinals, Inc. He currently steers both organizations as the chief executive officer. Mr. Sidman has direct experience providing services for medicinal marijuana facilities and has navigated the Sanctuary ATC team of New Hampshire into the selection of both locations for the cultivation/processing facility and the dispensing facility. Their 15,000 square feet grow center and laboratory is located in Rochester, NH at a hydroelectric facility while the dispensing location is in Plymouth, NH in a building that was once awarded the "Greenest Home in America" designation. These decisions as well as the design and choice of equipment was all the result of a deep developed expertise from intense research and study. Having visited over 25 production, retail and processing facilities in states with approved medical cannabis programs, Mr. Sidman has garnered tremendous insight into what it takes to run a successful medical marijuana organization. Their development of work flow optimization, security system design, facility layouts, hiring and staffing models, organic/pesticide free growing, as well as retail best practices have been instrumental throughout the program process.

Mr. Sidman is a general partner at WelCan Capital (www.WelCancap.com). WelCan Capital brings a unique, diversified approach to investing in the cannabis industry. With operating expertise and access to strategic relationships, WelCan strives to unlock value in foundational businesses across the cannabis ecosystem – all while supporting education,

research, and charitable causes aligned with this emerging industry. Additionally, Jason is a managing partner at Planet Green LLC, joining the team in January of 2014. Planet Green (www.planetgreenpower.com) located in Meredith, NH is a full service renewable energy company that provides a full range of design, installation and equipment for residential, commercial and municipal applications.

As for how this experience will ensure the success of Sanctuary, Mr. Sidman's experience will foster a team environment focused on helping those in need and providing them with the best possible organic products, education and value. In witnessing illness and suffering in his own family, he understands the significance of proper medicine, research and compassion. Mr. Sidman's experiences, coupled with his integrity, have made him a successful business owner and he looks forward to serving the medical marijuana industry in Massachusetts with the same sense of skill, knowledge and pride.

James Alex, COO/President

James Alex is a commercial real estate professional of notable status. With 27 years of experience working with some of the nation's largest retailers, Mr. Alex implemented and executed on growth strategies for retailers including: Target, Stop & Shop, CVS, Best Buy, Petco, Bed, Bath and Beyond, Staples and many others. For 17 years, 10 of which as acting President, Mr. Alex lead a team of Brokers at Atlantic Retail Properties. With offices in Boston, Florida and North Carolina, Mr. Alex negotiated more than 650 lease/sale transactions with an aggregate value of over a billion dollars. The strong tenant relationships that Mr. Alex built resulted in site acquisition assignments from some of the nation's top retailers highlighted by Target's entry into the New England market in 1995. Since then, Mr. Alex and his team successfully transacted 77 retail locations on their behalf. By developing a network of strategic partners, Mr. Alex successfully directed and coordinated leasing efforts, acquisition of land and disposition of large parcels along the eastern seaboard for many Fortune 500 Companies.

Alternative energy is of great interest to Mr. Alex and resulted in his role as a Board of Directors member and an early on investor at Wing Power Energy. As a Board Member, Mr. Alex's leadership has allowed Wing Power to continue to deliver high performance, durable, scalable wind powered microgrid solutions ensuring local, reliable, efficient and affordable energy while minimizing environmental impact. Mr. Alex is also a serial entrepreneur and investor in a variety of industries.

In conjunction with his business interests, Mr. Alex has spent considerable time pursuing charitable endeavors. He has been a Board Member at Melmark of New England since 2006. Melmark is a private, not for profit, community based organization dedicated to serving children and adolescents with autism spectrum disorders. Mr. Alex is the founder and sponsor of "The *fore* Melmark New England Golf Benefit for Children with Autism". In the last 10 years, the golf tournament has raised over \$2 million dollars that goes directly to the school. Additionally, Mr. Alex has been a Board Member since 2005 with Challenge Unlimited at Ironstone Farm, a provider of beneficial therapy for people with a wide range of physical, emotional and cognitive disabilities. Mr. Alex also serves as a Board Member and Fund Raising Committee at the Andover Youth Service (AYS), which provides young people a network of affordable, safe and challenging youth programs that promote healthy growth and development.

Mr. Alex has continued his philanthropic mission as a volunteer at Sanctuary ATC. Mr. Alex has used his business experience to assist the non-profit in marketing, advertising and branding their organic products to the medical cannabis community. By invoking a targeted message strategy, educating patients based on individual qualifying conditions has become more streamlined in process. Furthermore, Mr. Alex has worked with the cultivation team to increase efficiencies through better regulation of inventory management and logistical coordination between facilities. By focusing on quality control and product consistency, Mr. Alex has provided policy and procedural know how that has allowed for improved internal structure.

In addition to volunteering on the corporate side, Mr. Alex has provided expertise and knowledge to patients at the dispensary regarding therapeutic cannabis products, strains, administration methods, effects and uses. Aside from patient consulting, educating physicians has also been a significant role of his with Sanctuary ATC. Mr. Alex's experience and work with Sanctuary ATC has helped further the non-profit mission as well as its altruistic pursuits.

Josh Weaver, CFO

Josh Weaver was born and raised in a small town in central Pennsylvania: Lewistown, PA. In 1996, Mr. Weaver earned a Finance degree from the Pennsylvania State University graduating with Distinction while working part-time in the College of Health and Human Development as a work/study research assistant.

In 1996, Mr. Weaver started his career in New York City working for the audit team of Price Waterhouse. His main clients were several Fortune 500 Companies that included: The Interpublic Group, Sony Entertainment and International Flavors and Fragrances. In 1998, Mr. Weaver continued his career by accepting a position at Merrill Lynch in their investment banking division. He worked as a financial analyst on debt/equity and merger & acquisition deals with a wide range of clients.

From 2002 through 2010, Mr. Weaver, along with Jason Sidman, was an owner, founder and managing partner of PTG Capital LLC and PTG Trading LLC, equity trading firms with over 70 traders in 5 branches throughout the Northeast. Headquartered in New York City, they hired, trained and supervised the firm's traders, established the marketing and human resources divisions implemented automated risk management controls and procedures, maintained and insured the firm's legal compliance with internal control procedures. They also worked with software developers to create the firm's high frequency trading quant division. Under the leadership of Mr. Weaver, PTG Capital grew to trading in excess of \$100 million while executing 5 million shares daily.

Mr. Weaver was the founding partner and owner of Castaway Capital LLC from 2010 through 2015 where he developed automated trading applications for futures, equities, options and forex programs. Mr. Weaver and his team of programmers specialized in developing algorithms for commodity contracts of gold, silver, oil, corn and soybeans.

More recently, Mr. Weaver is a founding member of Sanctuary ATC. He was the co-author of Sanctuary ATC's successful application for the State of New Hampshire's Therapeutic Cannabis Program and has run the organization in strict compliance with New Hampshire and the Department of Health and Human Services regulations, guidance and nonprofit practices. Sanctuary ATC, was awarded the largest territory in New Hampshire with a vertically integrated license to cultivate, dispense and process cannabis. Mr. Weaver propelled Sanctuary ATC to be the first alternative treatment center to be registered, licensed and operational in the State of New Hampshire. At Sanctuary ATC, Mr. Weaver has many responsibilities, which include: CFO, Head of Human Resources and Chief of Compliance.

Although, he has gained some material success, Mr. Weaver still feels fortunate to have had the opportunities he has been afforded. Growing up in rural Pennsylvania with two blue collar parents, what his family did not have materially was more than made up for with the attributes of hard work, character, integrity and charity. Knowing that people are never defined only by financial success, he has carried these traits onward to his own family life. Having seen members of his own family suffering at different stages in their lives, makes it more vital than ever for him wanting to help to enact change and improve people's quality of life. Mr. Weaver resides with his wife of five years, Marzena, and their daughters, Tatiana, Vienna and Vera.

INVESTMENT RETURNS				
	2018	2019	2020	2021
Net Income (Medical)	\$ 2,330,492	\$ 6,384,854	\$ 7,997,971	\$ 9,832,223
Net Income (Adult-Use)	\$ 5,269,476	\$ 8,264,615	\$ 8,253,336	\$ 8,253,336
Net Income (Wholesale)	\$ 816,915	\$ 7,246,555	\$ 5,732,168	\$ 4,376,031
	\$ 8,416,882	\$ 21,896,025	\$ 21,983,475	\$ 22,461,591
Distributions				
Invested Capital				
Return of Invested Capital	\$ 8,416,882	\$ 2,583,118	\$ -	\$ -
Net Distributions to ALL LTD	\$ -	\$ 19,312,907	\$ 21,983,475	\$ 22,461,591
Investor Share (M)	\$ -	\$ 2,252,648	\$ 3,199,188	\$ 3,932,889
Investor Share (A)	\$ -	\$ 4,104,386	\$ 4,195,651	\$ 3,788,810
Total Distribution to Invest	\$ 8,416,882	\$ 6,357,034	\$ 7,394,840	\$ 7,721,700
Return of Investment Capit	56%	73%		
ROI		42%	49%	51%
IRR	56%	51%	50%	50%

PRODUCTION ANALYSIS

	2 ROOMS	8 ROOMS
Flower Rooms Operating	2	8
Levels	3	3
Lights per Level	70	70
Lights Running	420	1,680
Pounds per Light Average*	1.5	1.5
Harvests Year per Room	6	6
Total Pounds Produced	3,780	15,120
Average Price/Pound (DISPENSARY SALES)	\$ 5,600	\$ 5,600
Total Revenue (IF ALL SOLD AT DISPENSARY)	\$ 21,168,000	\$ 84,672,000
Average Price/Pound (WHOLESALE)**	\$ 2,500	\$ 2,500
Total Revenue (IF ALL SOLD WHOLESALE)	\$ 9,450,000	\$ 37,800,000

*Sanctuary averages 1.75+ pounds per Light

**Current MA Wholesale price is \$2800+

Adult-Use Site Analysis

	Brookline	MARKET STUDY	
	2019	2020	2021
Adult Use: For-Profit			
Serviceable Market	100,248	100,248	100,248
Consumer Population****	7.1%	7.2%	7.3%
Total Consumers	5,338	7,218	7,318
Oz per Month/Consumer	0.5	0.5	0.5
Active Consumer Percent	85%	85%	85%
Total Active Customers	4,537	6,135	6,220
Total Ounces Purchased	27,225	36,811	37,322
Total Pounds Purchased	1,702	2,301	2,333
Cultivation Avg Production Cost per \$/lb	\$ 1,200	\$ 1,200	\$ 1,200
Cultivation Avg Production Cost per \$/oz	\$ 75.00	\$ 75.00	\$ 75.00
Dispensary Avg \$/lb	\$ 4,800.00	\$ 4,800.00	\$ 4,800.00
Dispensary Avg Selling \$/oz	\$ 300.00	\$ 300.00	\$ 300.00
Paraphernalia Margin	50%	50%	50%
Paraphernalia Sales	5%	5%	5%
Sales Tax	20.00%	20.00%	20.00%
Corporate Tax***	21.00%	21.00%	21.00%
Cannabis Sales	\$ 8,167,455	\$ 11,043,320	\$ 11,196,699
Other Sales (paraphernalia, etc)	\$ 408,373	\$ 552,166	\$ 559,835
Total Revenue	\$ 8,575,828	\$ 11,595,486	\$ 11,756,534
Cultivation Charge (COGS)	\$ 2,246,050	\$ 3,036,913	\$ 3,079,092
Gross Profit	\$ 6,329,778	\$ 8,558,573	\$ 8,677,442
Operating Expenses (30% of Gross Profit)**	\$ 1,898,933	\$ 2,567,572	\$ 2,603,233
HCA	\$ 267,275	\$ 357,865	\$ 362,696
Operating Income	\$ 4,163,570	\$ 5,633,136	\$ 5,711,513
Income Taxes*	\$ 874,350	\$ 1,182,959	\$ 1,199,418
280E Tax	\$ 64,860	\$ 87,647	\$ 88,862
Net Income	\$ 2,957,085	\$ 4,004,667	\$ 4,060,538

Wholesale Forecast				
20,000lb+ per year capacity				
1680 Light Facility				
	2018	2019	2020	2021
Flower Rooms Used	4	8	8	8
Lights Running	840	1680	1680	1680
Pounds per Light Average*	1.5	1.5	1.5	1.5
Harvests Year per Room	6	6	6	6
Total Pounds Produced	3,780	15,120	15,120	15,120
Retail Pounds Sold	2,971	6,999	7,727	8,472
Wholesale Pounds	809	8,121	7,393	6,648
Wholesale Price	\$ 2,500	\$ 2,250	\$ 2,000	\$ 1,750
Total Revenue	\$ 2,023,348	\$ 18,272,107	\$ 14,786,967	\$ 11,633,607
Sanctuary Cost Per Pound**	\$ 1,200	\$ 1,100	\$ 1,000	\$ 900
Sanctuary Total Cost of Production	\$ 971,207	\$ 8,933,030	\$ 7,393,483	\$ 5,982,998
Operating Income	\$ 1,052,141	\$ 9,339,077	\$ 7,393,483	\$ 5,650,609
Corporate Tax Rate***	21%	21%	21%	21%
Income Taxes	\$ 220,950	\$ 1,961,206	\$ 1,552,632	\$ 1,186,628
280E Tax	\$ 14,277	\$ 131,316	\$ 108,684	\$ 87,950
Net Income	\$ 816,915	\$ 7,246,555	\$ 5,732,168	\$ 4,376,031
Accounting for partial year production in 2018				
Not inclusive of wholesale MIP (which traditionally yields 2-5x profit margin)				
*Sanctuary averages 1.75+ pounds per Light				
**Sanctuary has the ability to cultivate for \$400/lb				
***Corporate Tax Rate expected to be closer to a blended 18.5% all in rate				

MA Adult-Use Revenue by County								
County	Population	Consumers	Oz Purchased	Estimated Revenue				
Barnstable	214,914	15,044	144,422	\$ 50,547,773				
Berkshire	128,715	9,010	86,496	\$ 30,273,768				
Bristol	554,194	38,794	372,418	\$ 130,346,429				
Dukes	17,356	1,215	11,663	\$ 4,082,131				
Essex	769,091	53,836	516,829	\$ 180,890,203				
Franklin	70,862	4,960	47,619	\$ 16,666,742				
Hampden	468,161	32,771	314,604	\$ 110,111,467				
Hampshire	160,939	11,266	108,151	\$ 37,852,853				
Middlesex	1,570,315	109,922	1,055,252	\$ 369,338,088				
Nantucket	10,856	760	7,295	\$ 2,553,331				
Norfolk	692,254	48,458	465,195	\$ 162,818,141				
Plymouth	507,022	35,492	340,719	\$ 119,251,574				
Suffolk	767,254	53,708	515,595	\$ 180,458,141				
Worcester	813,475	56,943	546,655	\$ 191,329,320				
Totals	6,745,408	472,179	4,532,914	\$ 1,586,519,962				
http://www.thecannabist.co/2015/06/15/colorado-marijuana-use-state-survey/36136/ http://www.masslive.com/marijuana/index.ssf/2017/09/legal_recreational_marijuana_w.html								
<table border="1"> <tr> <td>Key</td> </tr> <tr> <td>Adult-Use Percentage</td> </tr> <tr> <td>Avg purchase month in OZ</td> </tr> <tr> <td>Price OZ*</td> </tr> </table>					Key	Adult-Use Percentage	Avg purchase month in OZ	Price OZ*
Key								
Adult-Use Percentage								
Avg purchase month in OZ								
Price OZ*								
*Inclusive of MIP (2-5x margin)								

Qualifications and Training

Sanctuary will ensure that all employees hired to work at a Sanctuary facility will be qualified to work as a marijuana establishment agent and properly trained to serve in their respective roles in a compliant manner.

Qualifications

In accordance with 935 CMR 500.030, a candidate for employment as a marijuana establishment agent must be 21 years of age or older. In addition, the candidate cannot have been convicted of a criminal offense in the Commonwealth involving the distribution of controlled substances to minors, or a like violation of the laws of another state, the United States, or foreign jurisdiction, or a military, territorial, or Native American tribal authority.

Sanctuary will also ensure that its employees are suitable for registration consistent with the provisions of 935 CMR 500.802. In the event that Sanctuary discovers any of its agents are not suitable for registration as a marijuana establishment agent, the agent's employment will be terminated, and Sanctuary will notify the Commission within one (1) business day that the agent is no longer associated with the establishment.

Training

As required by 935 CMR 500.105(2), and prior to performing job functions, each of Sanctuary's agents will successfully complete a comprehensive training program that is tailored to the roles and responsibilities of the agent's job function. Agent training will at least include the Responsible Vendor Program and eight (8) hours of on-going training annually.

On or after July 1, 2019, all of Sanctuary's current owners, managers, and employees will have attended and successfully completed a Responsible Vendor Program operated by an education provider accredited by the Commission to provide the annual minimum of two hours of responsible vendor training to marijuana establishment agents. Sanctuary's new, non-administrative employees will complete the Responsible Vendor Program within 90 days of the date they are hired. Sanctuary's owners, managers, and employees will then successfully complete the program once every year thereafter. Sanctuary will also encourage administrative employees who do not handle or sell marijuana to take the responsible vendor program on a voluntary basis to help ensure compliance. Sanctuary's records of responsible vendor training program compliance will be maintained for at least four (4) years and made available during normal business hours for inspection by the Commission and any other state licensing authority upon request.

As part of the Responsible Vendor program, Sanctuary's agents will receive training on a variety of topics relevant to marijuana establishment operations, including but not limited to the following:

1. Marijuana's effect on the human body, including physical effects based on different types of marijuana products and methods of administration, and recognizing the visible signs of impairment;
2. Best practices for diversion prevention and prevention of sales to minors;
3. Compliance with tracking requirements;
4. Acceptable forms of identification, including verification of valid photo identification and medical marijuana registration and confiscation of fraudulent identifications;
5. Such other areas of training determined by the Commission to be included; and
6. Other significant state laws and rules affecting operators, such as:
 - Local and state licensing and enforcement;
 - Incident and notification requirements;
 - Administrative and criminal liability and license sanctions and court sanctions;
 - Waste disposal and health and safety standards;
 - Patrons prohibited from bringing marijuana onto licensed premises;
 - Permitted hours of sale and conduct of establishment;
 - Permitting inspections by state and local licensing and enforcement authorities;
 - Licensee responsibilities for activities occurring within licensed premises;
 - Maintenance of records and privacy issues; and
 - Prohibited purchases and practices.

Diversity Plan

Sanctuary Medicinals, LLC (“Sanctuary”) believes in creating and sustaining a robust policy of inclusivity and diversity. Sanctuary recognizes that diversity in the workforce is key to the integrity of a company’s commitment to its community. Sanctuary is dedicated to creating a diverse culture with a commitment to equal employment opportunity for all individuals. Sanctuary’s diversity plan is designed to promote equity among minorities, women, veterans, people with disabilities, and people of all gender identities and sexual orientations. Sanctuary will make every effort to employ and advance in employment qualified and diverse people at all levels within the company.

Sanctuary’s executives and leadership are committed to successful implementation of Sanctuary’s Diversity Plan. Sanctuary’s executive management team believes that increased diversity will provide Sanctuary with a richer perspective and approach to its business.

Sanctuary believes in creating and sustaining a robust policy of inclusivity and diversity because Sanctuary recognizes that diversity in the workforce is key to the integrity of a company’s commitment to the community where it is established. Coupled with that vision, Sanctuary also wants to ensure that its customers see themselves in the makeup of Sanctuary’s employees.

Sanctuary’s comprehensive diversity empowerment plan is a pillar of its purpose-driven company. To better serve Sanctuary’s customers, Sanctuary aims to create an environment where personal identities, race, military service, sexual orientation, and heritage are utilized, celebrated, and valued. Sanctuary’s diversity initiatives and strategies are designed to attract, develop, and advance the most talented individuals regardless of their race, sexual orientation, religion, age, gender, disability status, or any other dimension of diversity.

Diversity Recruitment and Sourcing

Sanctuary will establish and maintain an inclusive and diverse workforce to serve its customers through innovative corporate recruitment of underrepresented and minority communities.

Sanctuary has developed strategic corporate initiatives to ensure a diverse and qualified staff stands ready to serve Sanctuary customers’ needs. These strategic corporate initiatives include:

- Hosting career fairs in underrepresented and minority communities;
- Provide cultural training on cultural sensitivity and recognizing unconscious bias; and
- Using suppliers who are also committed to diversity and inclusion.

Sanctuary’s recruitment efforts are designed to maintain a steady flow of qualified diverse applicants and includes the following steps:

- Developing relationships with organizations serving minorities, women, people of all gender identities and sexual orientations, veterans, and persons with disabilities for employment referrals;
- Providing briefings to representatives from recruitment sources concerning current and future job openings;
- Encouraging employees from diverse groups to refer applicants for employment;
- Participating in career day programs and encouraging Sanctuary's diverse employees to participate whenever possible;
- Establishing recruitment efforts at higher learning institutions, and institutions with special programs that reach diverse people;
- Developing relationships with community child care, housing, transportation, and other programs designed to improve employment opportunities for diverse persons;
- Ensuring that job openings are sent to community partners; and
- Utilizing Zip Recruiter to reach over 100 online career and job websites, as well as social media.

Employee Retention, Training and Development

Sanctuary will offer promotions, career counseling, and training to provide all employees with equal opportunity for growth and to decrease turnover. Sanctuary will ensure that all employees are given equal opportunities for promotion by communicating opportunities, training programs, and clearly-defined job descriptions. Sanctuary will ensure that all employees receive equal opportunity for career counseling, counsel employees on advancement opportunities, and provide training programs to assist them in career development. Sanctuary will instruct managers and supervisors to refer employees seeking career counseling to the Human Resources Manager.

Sanctuary's diversity awareness training emphasizes Sanctuary's zero-tolerance commitment of harassment and discrimination and Sanctuary's strict adherence to take corrective action should any issues, concerns, or complaints arise. All Sanctuary employees are required to complete the diversity awareness training program during employee orientation. Training will begin immediately upon hiring, and all new employees will be required to participate in an orientation program that will introduce and stress the importance of the Diversity Plan.

Upon completion of the orientation program, new hires will be equipped to describe, discuss, and implement the Diversity Plan. Following successful completion of the general orientation program, employees will undergo additional diversity training that will be tailored to the employee's specific job function. All employees will also be required to undergo ongoing diversity training to ensure knowledge of newly determined best practices and policies and continued familiarity and compliance with the Diversity Plan.

Awareness of Diversity Plan goals and Sanctuary's efforts to create an open culture with zero tolerance for discrimination, harassment, or retaliation, is crucial to Sanctuary's success. Management, staff, associates, vendors, contractors, and the general public all benefit from being informed of the Diversity Plan objectives and procedures. Dissemination of information of the Diversity Plan includes the following:

- Inclusion of Sanctuary's Equal Employment Opportunity and Reasonable Accommodation statement in the Employee Handbook;
- Inclusion of Sanctuary's zero-tolerance policies for harassment, discrimination, bullying, and other actions which oppose Sanctuary's goal for a diverse workforce;
- Postings in suitable areas for employee communication;
- Diversity training programs for all employees;
- Quarterly progress evaluation meetings with appropriate personnel; and
- Formal presentations made to management and employees on diversity initiatives.

Strategic Partnerships, Suppliers and Vendors

Sanctuary will partner with local organizations focused on inclusion and opportunity for minorities, women, veterans, groups concerned with persons with disabilities, and people of all gender identities and sexual orientations.

Sanctuary will promote diversity and support the local economy through purchasing goods and services from vendors, contractors, and professional service providers that are owned and operated by individuals that have cultural and ethnically diverse characteristics. In selecting potential contractors, subcontractors, vendors and suppliers, Sanctuary will first contract with small and diverse businesses. Sanctuary's goal is to maintain diverse organization, vendor, and contractor spending at or above 20% of total related expenses.

External communication efforts that align with Sanctuary's Diversity Plan will include:

- Advertising in employment and business sections of appropriate types of media;
- Participating in employment and business notification programs; and
- Distribution of literature to organizations actively supportive of minorities, women, disabled persons, the LGBTQ community, and veterans.

Measuring Progress

Sanctuary has established a Diversity Committee (the "Committee") to assist the executive management team with the implementation and growth of the Diversity Plan. The initial members of the Committee were selected based on their diverse status and their personal commitments to diversity. Additional members of the Committee may be added at the discretion of Sanctuary's executive management team.

The Committee will be responsible for:

- Developing Equal Employment Opportunity (EEO) statements, policies, programs, and internal and external communication procedures in support of the goals of the Diversity Plan;
- Assisting in the identification of problematic areas for EEO, including receiving, reviewing, and resolving any complaints of discrimination or other non-compliance with regards to equal opportunity and fair treatment of all employees;
- Assisting management in arriving at effective solutions to problems regarding issues of diversity and inclusion;
- Designing and implementing internal reporting systems that measure the effectiveness of programs designed to support a company culture that fosters diversity;
- Keeping the company informed of equal opportunity progress through quarterly reports;
- Reviewing the Diversity Plan with management at all levels of Sanctuary to ensure that the Diversity Plan is understood; and
- Auditing Sanctuary's internal and external job postings to ensure information is in compliance with Sanctuary's diversity policies and procedures.

The CEO at Sanctuary will be responsible for auditing the Diversity Plan. The audit report setting forth the Company's performance in fulfilling the goals of the Plan will contain:

- Employment data, including information on minority, women, disabled, and veteran representation in the workforce in all job classifications; average salary ranges; recruitment and training information (all job categories); and retention and outreach efforts;
- The total number and value of all contracts and/or subcontractors awarded for goods and services;
- An identification of each subcontract actually awarded to a member of a diverse group and the actual value of such subcontract;
- A comprehensive description of all efforts made by Sanctuary to monitor and enforce the Diversity Plan;
- Information on diverse group investment, equity ownership, and other ownership or employment opportunities initiated or promoted by Sanctuary;
- Other information deemed necessary or desirable by the Commission to ensure compliance with the rules and regulations governing marijuana establishments in Massachusetts; and
- When available, a workforce utilization report including the following information for each job category at Sanctuary:
 - The total number of persons employed
 - The total number of men employed
 - The total number of women employed
 - The total number of veterans
 - The total number of service-disabled veterans

- The total number of members of each racial minority employed

Maintaining of Financial Records

Sanctuary Medicinals, LLC's ("Sanctuary") operating policies and procedures ensure financial records are accurate and maintained in compliance with the Commission's Adult Use of Marijuana regulations (935 CMR 500). Financial records maintenance measures include policies and procedures requiring that:

- Confidential information will be maintained in a secure location, kept separate from all other records, and will not be disclosed without the written consent of the individual to whom the information applies, or as required under law or pursuant to an order from a court of competent jurisdiction; provided however, the Commission may access this information to carry out its official duties.
- All recordkeeping requirements under 935 CMR 500.105(9) are followed, including:
 - Keeping written business records, available for inspection, and in accordance with generally accepted accounting principles, which will include manual or computerized records of:
 - Assets and liabilities;
 - Monetary transactions;
 - Books of accounts, which will include journals, ledgers, and supporting documents, agreements, checks, invoices, and vouchers;
 - Sales records including the quantity, form, and cost of marijuana products; and
 - Salary and wages paid to each employee and any executive compensation, bonus, benefit, or item of value paid to any individual affiliated with a marijuana establishment, including members, if any.
- All sales recording requirements under 935 CMR 500.140(6) are followed, including:
 - Utilizing a point-of-sale (POS) system approved by the Commission, in consultation with the DOR, and a sales recording module approved by DOR;
 - Conducting a monthly analysis of its equipment and sales date, and maintaining records, available to the Commission upon request, that the monthly analysis has been performed;
 - Complying with 830 CMR 62C.25.1: *Record Retention* and DOR Directive 16-1 regarding recordkeeping requirements;
 - Adopting separate accounting practices at the point-of-sale for marijuana and marijuana product sales, and non-marijuana sales;
 - Maintaining such records that would allow for the Commission and the DOR to audit and examine the point-of-sale system used in order to ensure compliance with Massachusetts tax laws and 935 CMR 500; and
 - If colocated with a medical marijuana treatment center, maintaining and providing the Commission on a biannual basis accurate sales data collected by the licensee during the six months immediately preceding this application for the purpose of

ensuring an adequate supply of marijuana and marijuana products under 935 CMR 500.140(10).

- Additional written business records will be kept, including, but not limited to, records of:
 - Compliance with liability insurance coverage or maintenance of escrow requirements under 935 CMR 500.105(10) and all bond or escrow requirements under 935 CMR 500.105(16);
 - Fees paid under 935 CMR 500.005 or any other section of the Commission's regulations; and
 - Fines or penalties, if any, paid under 935 CMR 500.550 or any other section of the Commission's regulations.

Recordkeeping Procedures

General Overview

Sanctuary Medicinals, LLC (“Sanctuary”) has established policies regarding recordkeeping and record-retention in order to ensure the maintenance, safe keeping, and accessibility of critical documents. Electronic and wet signatures are accepted forms of execution of Sanctuary documents. Records will be stored at Sanctuary in a locked room designated for record retention. All written records will be available for inspection by the Commission upon request.

Recordkeeping

To ensure that Sanctuary is keeping and retaining all records as noted in this policy, reviewing Corporate Records, Business Records, and Personnel Records to ensure completeness, accuracy, and timeliness of such documents will occur as part of Sanctuary’s quarter-end closing procedures. In addition, Sanctuary’s operating procedures will be updated on an ongoing basis as needed and undergo a review by the executive management team on an annual basis.

- **Corporate Records**: are defined as those records that require, at a minimum, annual reviews, updates, and renewals, including:
 - Insurance Coverage:
 - Directors & Officers Policy
 - Product Liability Policy
 - General Liability Policy
 - Umbrella Policy
 - Workers Compensation Policy
 - Employer Professional Liability Policy
 - Third-Party Laboratory Contracts
 - Commission Requirements:
 - Annual Agent Registration
 - Annual Marijuana Establishment Registration
 - Local Compliance:
 - Certificate of Occupancy
 - Special Permits
 - Variances
 - Site Plan Approvals
 - As-Built Drawings
 - Corporate Governance:
 - Annual Report
 - Secretary of State Filings
- **Business Records**: Records that require ongoing maintenance and updates. These records can be electronic or hard copy (preferably electronic) and at minimum include:
 - Assets and liabilities;

- Monetary transactions;
- Books of accounts, which will include journals, ledgers, and supporting documents, agreements, checks, invoices, and vouchers;
- Sales records including the quantity, form, and cost of marijuana products;
- Salary and wages paid to each agent, and any executive compensation, bonus, benefit, or item of value paid to any individual affiliated with Sanctuary, including members, if any.
- Personnel Records: At a minimum will include:
 - Job descriptions for each agent and volunteer position, as well as organizational charts consistent with the job descriptions;
 - A personnel record for each marijuana establishment agent. Such records will be maintained for at least twelve (12) months after termination of the agent's affiliation with Sanctuary and will include, at a minimum, the following:
 - All materials submitted to the Commission pursuant to 935 CMR 500.030(2);
 - Documentation of verification of references;
 - The job description or employment contract that includes duties, authority, responsibilities, qualifications, and supervision;
 - Documentation of all required training, including training regarding privacy and confidentiality requirements, and the signed statement of the individual indicating the date, time, and place he or she received said training and the topics discussed, including the name and title of presenters;
 - Documentation of periodic performance evaluations; and
 - A record of any disciplinary action taken.
 - Notice of completed responsible vendor and eight-hour related duty training.
 - A staffing plan that will demonstrate accessible business hours and safe cultivation conditions;
 - Personnel policies and procedures; and
 - All background check reports obtained in accordance with 935 CMR 500.030.
- Handling and Testing of Marijuana Records
 - Sanctuary will maintain the results of all testing for a minimum of one (1) year.
- Inventory Records
 - The record of each inventory will include, at a minimum, the date of the inventory, a summary of the inventory findings, and the names, signatures, and titles of the agents who conducted the inventory.
- Seed-to-Sale Tracking Records
 - Sanctuary will use BioTrack THC to maintain real-time inventory. BioTrack THC inventory reporting meets the requirements specified by the Commission and 935

CMR 500.105(8)(c) and (d), including, at a minimum, an inventory of marijuana plants; marijuana plant-seeds and clones in any phase of development such as propagation, vegetation, flowering; marijuana ready for dispensing; all marijuana products; and all damaged, defective, expired, or contaminated marijuana and marijuana products awaiting disposal.

- Inventory records will include, at a minimum, the date of the inventory, a summary of the inventory findings, and the names, signatures, and titles of the individuals who conducted the inventory.
- Incident Reporting Records
 - Within ten (10) calendar days, Sanctuary will provide written notice to the Commission of any incident described in 935 CMR 500.110(7)(a), by submitting an incident report, detailing the incident, the investigation, the findings, resolution (if any), confirmation that the Police Department and Commission were notified within twenty-four (24) hours of discovering the breach, and any other relevant information. Reports and supporting documents, including photos and surveillance video related to a reportable incident, will be maintained by Sanctuary for no less than one year or the duration of an open investigation, whichever is longer, and made available to the Commission and law enforcement authorities upon request.
- Visitor Records
 - A visitor sign-in and sign-out record will be maintained at the security office. The record will include the visitor's name, address, organization or firm, date, time in and out, and the name of the authorized agent who will be escorting the visitor.
- Waste Disposal Records
 - When marijuana or marijuana products are disposed of, Sanctuary will create and maintain a written record of the date, the type and quantity disposed of or handled, the manner of disposal or other handling, the location of disposal or other handling, and the names of the two Sanctuary agents present during the disposal or handling, with their signatures. Sanctuary will keep disposal records for at least three (3) years. This period will automatically be extended for the duration of any enforcement action and may be extended by an order of the Commission.
- Security Records
 - A current list of authorized agents and service personnel that have access to the surveillance room will be available to the Commission upon request.
 - Twenty-four (24) hour recordings from all video cameras that are available for immediate viewing by the Commission upon request and that are retained for at least ninety (90) calendar days.
- Transportation Records

- Sanctuary will retain all shipping manifests for a minimum of one (1) year and make them available to the Commission upon request.
- Agent Training Records
 - Documentation of all required training, including training regarding privacy and confidentiality requirements, and a signed statement of the individual indicating the date, time, and place he or she received the training, the topics discussed and the name and title of the presenter(s).
- Closure
 - In the event Sanctuary closes, all records will be kept for at least two (2) years at Sanctuary's expense in a form (electronic, hard copies, etc.) and location acceptable to the Commission. In addition, Sanctuary will communicate with the Commission during the closure process and accommodate any additional requests the Commission or other agencies may have.
- Written Operating Policies and Procedures: Policies and Procedures related to Sanctuary's operations will be updated on an ongoing basis as needed and undergo a review by the executive management team on an annual basis. Policies and Procedures will include the following:
 - Security measures in compliance with 935 CMR 500.110;
 - Agent security policies, including personal safety and crime prevention techniques;
 - A description of Sanctuary's hours of operation and after-hours contact information, which will be provided to the Commission, made available to law enforcement officials upon request, and updated pursuant to 935 CMR 500.000.
 - Storage of marijuana in compliance with 935 CMR 500.105(11);
 - Description of the various strains of marijuana to be cultivated, processed or sold, as applicable, and the form(s) in which marijuana will be dispensed;
 - Procedures to ensure accurate recordkeeping, including inventory protocols in compliance with 935 CMR 500.160;
 - Plans for quality control, including product testing for contaminants in compliance with 935 CMR 500.160;
 - A staffing plan and staffing records in compliance with 935 CMR 500.105(9);
 - Emergency procedures, including a disaster plan with procedures to be followed in case of fire or other emergencies;
 - Alcohol, smoke, and drug-free workplace policies;
 - A plan describing how confidential information will be maintained;
 - Policy for the immediate dismissal of any dispensary agent who has:
 - Diverted marijuana, which will be reported the Police Department and to the Commission;
 - Engaged in unsafe practices with regard to Sanctuary operations, which will be reported to the Commission; or

- Been convicted or entered a guilty plea, plea of *nolo contendere*, or admission to sufficient facts of a felony drug offense involving distribution to a minor in the Commonwealth, or a like violation of the laws of another state, the United States or a foreign jurisdiction, or a military, territorial, or Native American tribal authority.
- A list of all executives of Sanctuary, and members, if any, of the licensee must be made available upon request by any individual. 935 CMR 500.105(1)(m) requirement may be fulfilled by placing this information on Sanctuary's website.
- Policies and procedures for the handling of cash on Sanctuary premises including but not limited to storage, collection frequency and transport to financial institution(s).
- Policies and procedures to prevent the diversion of marijuana to individuals younger than 21 years old.
- Policies and procedures for energy efficiency and conservation that will include:
 - Identification of potential energy use reduction opportunities (including but not limited to natural lighting, heat recovery ventilation and energy efficiency measures), and a plan for implementation of such opportunities;
 - Consideration of opportunities for renewable energy generation, including, where applicable, submission of building plans showing where energy generators could be placed on site, and an explanation of why the identified opportunities were not pursued, if applicable;
 - Strategies to reduce electric demand (such as lighting schedules, active load management and energy storage); and
 - Engagement with energy efficiency programs offered pursuant to M.G.L. c. 25 § 21, or through municipal lighting plants.

Record-Retention

Sanctuary will meet Commission recordkeeping requirements and retain a copy of all records for two (2) years, unless otherwise specified in the regulations.

Quality Control and Testing

Quality Control

Sanctuary Medicinals, LLC (“Sanctuary”) will comply with the following sanitary requirements:

1. Any Sanctuary agent whose job includes contact with marijuana or nonedible marijuana products, including cultivation, production, or packaging, is subject to the requirements for food handlers specified in 105 CMR 300.000, and all edible marijuana products will be prepared, handled, and stored in compliance with the sanitation requirements in 105 CMR 500.000, and with the requirements for food handlers specified in 105 CMR 300.000.
2. Any Sanctuary agent working in direct contact with preparation of marijuana or nonedible marijuana products will conform to sanitary practices while on duty, including:
 - a. Maintaining adequate personal cleanliness; and
 - b. Washing hands thoroughly in an adequate hand-washing area before starting work, and at any other time when hands may have become soiled or contaminated.
3. Sanctuary’s hand-washing facilities will be adequate and convenient and will be furnished with running water at a suitable temperature. Hand-washing facilities will be located in Sanctuary’s production areas and where good sanitary practices require employees to wash and sanitize their hands, and will provide effective hand-cleaning and sanitizing preparations and sanitary towel service or suitable drying devices;
4. Sanctuary’s facility will have sufficient space for placement of equipment and storage of materials as is necessary for the maintenance of sanitary operations;
5. Sanctuary will ensure that litter and waste is properly removed and disposed of so as to minimize the development of odor and minimize the potential for the waste attracting and harboring pests. The operating systems for waste disposal will be maintained in an adequate manner pursuant to 935 CMR 500.105(12);
6. Sanctuary’s floors, walls, and ceilings will be constructed in such a manner that they may be adequately kept clean and in good repair;
7. Sanctuary’s facility will have adequate safety lighting in all processing and storage areas, as well as areas where equipment or utensils are cleaned;
8. Sanctuary’s buildings, fixtures, and other physical facilities will be maintained in a sanitary condition;
9. Sanctuary will ensure that all contact surfaces, including utensils and equipment, will be maintained in a clean and sanitary condition. Such surfaces will be cleaned and sanitized as frequently as necessary to protect against contamination, using a sanitizing agent registered by the US Environmental Protection Agency (EPA), in accordance with labeled instructions. Equipment and utensils will be so designed and of such material and workmanship as to be adequately cleanable;

10. All toxic items will be identified, held, and stored in a manner that protects against contamination of marijuana products;
11. Sanctuary will ensure that its water supply is sufficient for necessary operations, and that such water supply is safe and potable;
12. Sanctuary's plumbing will be of adequate size and design, and adequately installed and maintained to carry sufficient quantities of water to required locations throughout the marijuana establishment. Plumbing will properly convey sewage and liquid disposable waste from the marijuana establishment. There will be no cross-connections between the potable and waste water lines;
13. Sanctuary will provide its employees with adequate, readily accessible toilet facilities that are maintained in a sanitary condition and in good repair;
14. Sanctuary will hold all products that can support the rapid growth of undesirable microorganisms in a manner that prevents the growth of these microorganisms; and
15. Sanctuary will store and transport finished products under conditions that will protect them against physical, chemical, and microbial contamination, as well as against deterioration of finished products or their containers.

Sanctuary's vehicles and transportation equipment used in the transportation of marijuana products or edibles requiring temperature control for safety will be designed, maintained, and equipped as necessary to provide adequate temperature control to prevent the marijuana products or edibles from becoming unsafe during transportation, consistent with applicable requirements pursuant to 21 CFR 1.908(c).

Sanctuary will ensure that Sanctuary's facility is always maintained in a sanitary fashion and will comply with all applicable sanitary requirements.

Sanctuary will follow established policies and procedures for handling voluntary and mandatory recalls of marijuana products. Such procedures are sufficient to deal with recalls due to any action initiated at the request or order of the Commission, and any voluntary action by Sanctuary to remove defective or potentially defective marijuana products from the market, as well as any action undertaken to promote public health and safety.

Any inventory that becomes outdated, spoiled, damaged, deteriorated, mislabeled, or contaminated will be disposed of in accordance with the provisions of 935 CMR 500.105(12), and any such waste will be stored, secured, and managed in accordance with applicable state and local statutes, ordinances, and regulations.

Sanctuary will process marijuana in a safe and sanitary manner. Sanctuary will process the leaves and flowers of the female marijuana plant only, which will be:

- Well-cured and generally free of seeds and stems;

- Free of dirt, sand, debris, and other foreign matter;
- Free of contamination by mold, rot, other fungus, and bacterial diseases;
- Prepared and handled on food-grade stainless steel tables; and
- Packaged in a secure area.

All edible products will be prepared, handled, and stored in compliance with the sanitation requirements in 105 CMR 590.000: Minimum Sanitation Standards for Food Establishments.

Testing

Sanctuary will not sell or otherwise market marijuana or marijuana products that are not capable of being tested by Independent Testing Laboratories, except as allowed under 935 CMR 500.000. No marijuana product will be sold or otherwise marketed for adult use that has not first been tested by an Independent Testing Laboratory and deemed to comply with the standards required under 935 CMR 500.160. Testing of Sanctuary's marijuana products will be performed by an Independent Testing Laboratory in compliance with the Protocol for Sampling and Analysis of Finished Medical Marijuana Products and Marijuana-infused Products, as amended in November 2016, published by the DPH. Testing of Sanctuary's environmental media will be performed in compliance with the Protocol for Sampling and Analysis of Environmental Media for Massachusetts Registered Medical Marijuana Dispensaries published by the DPH.

Sanctuary's policy of responding to laboratory results that indicate contaminant levels are above acceptable limits established in the DPH protocols identified in 935 CMR 500.160(1) include notifying the Commission within 72 hours of any laboratory testing results indicating that the contamination cannot be remediated and disposing of the production batch. Such notification will describe a proposed plan of action for both the destruction of the contaminated product and the assessment of the source of contamination.

Sanctuary will maintain testing results in compliance with 935 CMR 500.000 *et seq* and the record keeping policies described herein, and will maintain the results of all testing for no less than one year.

All transportation of marijuana to and from Independent Testing Laboratories providing marijuana testing services will comply with 935 CMR 500.105(13). All storage of Sanctuary's marijuana at a laboratory providing marijuana testing services will comply with 935 CMR 500.105(11). All excess marijuana will be disposed in compliance with 935 CMR 500.105(12), either by the Independent Testing Laboratory returning excess marijuana to Sanctuary for disposal or by the Independent Testing Laboratory disposing of it directly.

Plan for Restricting Access to Age 21 and Older

Pursuant to 935 CMR 500.050(5)(b), Sanctuary Medicinals, LLC (“Sanctuary”) will only be accessible to consumers 21 years of age or older with a verified and valid, government-issued photo ID or in possession of a Program ID Card demonstrating the individual is a registered qualifying patient with the Medical Use of Marijuana Program. Upon entry into the premises of the marijuana establishment by an individual, a Sanctuary agent will immediately inspect the individual’s proof of identification and determine the individual’s age, in accordance with 935 CMR 500.140(2).

In the event Sanctuary discovers any of its agents intentionally or negligently sold marijuana to an individual under the age of 21, the agent will be immediately terminated and the Commission will be promptly notified, pursuant to 935 CMR 500.105(1)(l). Sanctuary will not hire any individuals who are under the age of 21 or who have been convicted of distribution of controlled substances to minors, pursuant to 935 CMR 500.030(1).

Pursuant to 935 CMR 500.105(4), Sanctuary will not engage in any marketing, advertising or branding practices that are targeted to, deemed to appeal to or portray minors under the age of 21. Sanctuary will not engage in any advertising, marketing and branding by means of television, radio, internet, mobile applications, social media, or other electronic communication, billboard or other outdoor advertising, including charitable, sporting or similar events, unless at least 85% of the audience is reasonably expected to be 21 years of age or older as determined by reliable and current audience composition data. Sanctuary will not manufacture or sell any edible products that resemble a realistic or fictional human, animal or fruit, including artistic, caricature or cartoon renderings, pursuant to 935 CMR 500.150(1)(b). In accordance with 935 CMR 500.105(4)(a)(5), any marketing, advertising and branding materials for public viewing will include a warning stating, **“For use only by adults 21 years of age or older. Keep out of the reach of children. Marijuana can impair concentration, coordination and judgment. Do not operate a vehicle or machinery under the influence of marijuana.”** Pursuant to 935 CMR 500.105(6)(b), Sanctuary packaging for any marijuana or marijuana products will not use bright colors, resemble existing branded products, feature cartoons or celebrities commonly used to market products to minors, feature images of minors or other words that refer to products commonly associated with minors or otherwise be attractive to minors. Sanctuary’s website will require all online visitors to verify they are 21 years of age or older prior to accessing the website, in accordance with 935 CMR 500.105(4)(b)(13).

Personnel Policies Including Background Checks

Overview

Sanctuary Medicinals, LLC (“Sanctuary”) will maintain personnel records as a separate category of records due to the sensitivity and importance of information concerning agents, including registration status and background check records. Sanctuary will keep, at a minimum, the following personnel records:

- Job descriptions for each employee and volunteer position, as well as organizational charts consistent with the job descriptions;
- A personnel record for each marijuana establishment agent;
- A staffing plan that will demonstrate accessible business hours and safe conditions;
- Personnel policies and procedures; and
- All background check reports obtained in accordance with 935 CMR 500.030.

Job Descriptions

Director of Security: Under the supervision of the Chief Executive Officer, the Director of Security is responsible for the development and overall management of the Security Policies and Procedures for Sanctuary, while implementing, administering, and revising the policies as needed. In addition, the Director of Security will perform the following duties:

- Provide general training to Sanctuary agents during new hire orientation or re-current trainings throughout the year;
- Provide training specific for Security Agents prior to the Security Agent commencing job functions;
- Review and approve incident reports and other reports written by Security Agents prior to submitting to the executive management team—follow up with security agent if needed;
- Maintain lists of agents authorized to access designated areas of the Sanctuary facility, including cash and product storage vaults, the surveillance and network equipment room, and other highly sensitive areas of the Sanctuary facility;
- Lead a working group comprised of the Chief Executive Officer, Chief Operating Officer, and any other designated advisors to ensure the current policies and procedures are properly implemented, integrated, effective, and relevant to ensure the safety of Sanctuary agents and assets;
- Ensure that all required background checks have been completed and documented prior to an agent performing job functions; ensure agent is granted appropriate level of access to the facility necessary to complete his/her job functions;
- Maintain all security-related records, incident reports and other reports written by security agents;
- Evaluate and determine the number of security agents assigned to each shift and proper shift change times; and
- Maintain frequent contact with local law enforcement authorities.

Security Agent: Security Agents monitor Sanctuary’s security systems including alarms, video surveillance, and motion detectors. Security Agents are responsible for ensuring that only authorized individuals are permitted access to the Sanctuary facility by verifying appropriate ID

cards and other forms of identification. In addition, Security Agents perform the following duties and other duties upon request:

- Investigate, communicate, and provide leadership in the event of an emergency such as an intrusion, fire, or other threat that jeopardizes customers, authorized visitors, and Sanctuary agents;
- Respond and investigate security situations and alarm calls; clearly document the incident and details surrounding the incident in a written report for the Director of Security;
- Oversee the entrance to the facility and verify credentials of each person seeking access to the Sanctuary facility;
- Answer routine inquiries;
- Log entries, and maintain visitor log;
- Escort authorized visitors in restricted access areas; and
- Escort Sanctuary agents from the facility during non-business hours and perform security checks at designated intervals.

Inventory Manager: The Inventory Manager is responsible for inventory on a day-to-day basis as well as the weekly and monthly inventory counts and waste disposal requirements. The inventory manager will perform the comprehensive annual inventory in conjunction with the executive management team. Additional duties include, but are not limited to:

- Implementing inventory controls to track and account for all dispensary inventory;
- Implementing procedures and notification policies for proper disposal;
- Maintaining records, including operating procedures, inventory records, audit records, storage and transfer records;
- Maintaining documents with each day's beginning, acquisitions, sales, disposal, and ending inventory; and
- Proper storing, labeling, tracking, and reporting of inventory.

Inventory Associate: Inventory Associates support the Inventory Manager during day-to-day operations. Responsibilities include, but are not limited to:

- Maintaining records, including operating procedures, inventory records, audit records, storage and transfer records;
- Maintaining documents with each day's beginning, acquisitions, sales, disposal and ending inventory;
- Ensuring products are properly stored, labeled, and recorded in the BioTrack THC system;
- Ensuring waste is properly stored; and
- Coordinating the waste disposal schedule and ensuring Sanctuary's policies and procedures for waste disposal are adhered to.

Human Resources Manager: The Human Resources Manager at Sanctuary will support the executive management team on a day-to-day basis to effectively implement all personnel policies and procedures for Sanctuary, including hiring processes. The Human Resources Manager will:

- Oversee hiring and release of Sanctuary agents;
- Review and revise Sanctuary personnel policies and procedures in consultation with the executive management team and department managers;

- Develop training schedules and policies for Sanctuary agents under the supervision of the executive management team and department managers;
- Handle any and all agent discipline as necessary;
- Ensure compliance with any and all workplace policy laws and requirements; and
- Be responsible for such additional human resources tasks as determined by the executive management team.

Director of Cultivation: The Director of Cultivation is responsible for all daily operations and maintenance of the Cultivation Facility. The Director of Cultivation will:

- Be responsible for implementing policies with the Cultivation Facility;
- Coordinate space assignments;
- Receive and review work requests;
- Coordinate repairs and maintenance;
- Supervise and train agents in an ongoing capacity;
- Provide mandatory training for new agents;
- Maintain a record of space allocations;
- Work with Cultivation Technicians to promote successful operations in the Cultivation Facility;
- Program and monitor the Direct Digital Control (DDC).
- Maintain a database of environmental controls and conditions;
- Adjust DDC for optimum efficiency of operation;
- Provide pesticide recommendations and ensure IPM Program is sufficient.

Cultivation Manager: The Cultivation Manager supervises and participates in all aspects of daily Cultivation Facility tasks. The Cultivation Manager operates under the supervision of the Director of Cultivation and will:

- Instruct Cultivation Technicians on operation procedures;
- Train and supervise Cultivation Technicians;
- Assist with the activities performed by all Cultivation Technicians;
- Instruct agents or apply pesticides with guidance from the Director of Cultivation;
- Perform routine maintenance;
- Maintain inventory of all cultivation supplies and order such supplies;
- Report daily to Director of Cultivation; and
- Coordinate with relevant staff regarding harvest schedules.

Cultivation Technician: Cultivation Technicians are responsible for all daily tasks in their assigned areas within the Cultivation Facility. Cultivation Technicians report directly to Cultivation Manager and/or Director of Cultivation. Responsibilities include, but are not limited to:

- Irrigation;
- Pruning;
- Pesticide application;
- Potting/Re-potting;
- Propagation;
- Light construction; and
- Janitorial duties (i.e. cleaning, disinfecting, sterilizing).

Production Manager: The Production Manager is responsible for all post-harvest handling of marijuana. The Production Manager coordinates directly with the Cultivation Manager regarding harvest schedules. Production Manager reports directly to the Director of Cultivation and is responsible for the following:

- Transitioning harvested plant material from cultivation rooms to the Trim Room where marijuana is trimmed via machine and manually;
- Overseeing Trim Technicians and delegates daily tasks to production agents;
- Ensuring quality control of finished marijuana flowers;
- Monitoring the status of the Dry Room and of marijuana flowers that are in the process of drying;
- Entering wet and dry weights of all product including flowers and trim into BioTrack THC;
- Working with Cultivation Technicians to ensure prompt transfer of marijuana trim to relevant room within the Cultivation Facility;
- Overseeing bulk packaging and storing in dedicated vault; and
- Relaying information to the Inventory Manager for sales purposes.

Trim Technicians: Trim Technicians are responsible for post-harvest trimming of marijuana plants, both mechanical and manual. Trim Technicians report directly to the Production Manager and are responsible for:

- Receiving daily tasks from the Production Manager;
- Assisting in the harvest of marijuana;
- Trimming marijuana plants;
- Maintaining a sterile environment in the Trim Room; and
- Cleaning and maintaining scissors and trim machines.

Production Manager: Responsible for production of all concentrates and marijuana products created by Sanctuary. This includes, but is not limited to:

- Managing inventory and par-levels of all concentrate and marijuana products, including integration into the BioTrack THC;
- Creating raw Super Critical CO₂ (SCCO₂) concentrate;
- Creating distilled, high-purity concentrate for use in marijuana products and vaporizer cartridges;
- Creating all marijuana products;
- Organizing extraction schedule based on availability of cultivated material;
- Maintaining a rigid cleaning schedule that all lab agents must adhere to;
- Ensuring safety pursuant to established safety protocols;
- Coordinating facility repairs and maintenance;
- Supervising and training agents in an ongoing manner; and
- Providing mandatory training for new agents.

Lab/Production Assistant: Responsible for supporting the Production Manager during day-to-day operations. This includes, but is not limited to:

- Drying and grinding cultivated material in preparation for SCCO₂ extraction;

- Unpacking and cleaning the SCCO2 extractor;
- Cleaning and sanitization of all lab glassware;
- Cleaning and sanitization of all kitchen cookware and utensils;
- Cleaning and sanitization of the distillation still;
- Routine scheduled maintenance of all equipment; and
- Assisting with packaging of all concentrate and marijuana products to be sold.

Retail Manager: Responsible for overseeing all Member Services Agents and managing day-to-day operations of the retail facility. This includes, but is not limited to:

- Implementing inventory tracking;
- Training retail staff;
- Ensuring customer satisfaction through feedback tools;
- Reporting all incidents and complaints to the executive team; and
- Working with bookkeeping to ensure precise data flow.

Member Services Agent: Member Services Agents ensure that each customer is treated with respect while at a Sanctuary facility and that each customer receives the appropriate amount of individualized attention in order to address his/her specific needs and questions. Member Services Agent responsibilities include, but are not limited to:

- Maintaining a clean, safe, healthy, and productive environment ensuring that customers have a positive experience at a Sanctuary facility;
- Answering customer questions regarding products including but not limited to flowers, concentrates, tinctures, and edibles;
- Being knowledgeable of strains and various types of products offered by Sanctuary;
- Properly setting up product displays pursuant to Sanctuary policies and procedures;
- Executing and enforcing compliance with Commission regulations and Sanctuary policies and procedures;
- Understanding sales transactions using BioTrack THC;
- Understanding individual customer goals;
- Reconciling cash from sales transactions, sales reports, and other forms of task management daily; and
- Participating in ongoing education and professional development as required.

Agent Personnel Records

Personnel records for each agent will be maintained for at least twelve (12) months after termination of the agent's affiliation with Sanctuary and will include, at a minimum, the following:

- All materials submitted to the Commission pursuant to 935 CMR 500.030(2);
- Documentation of verification of references;
- The job description or employment contract that includes duties, authority, responsibilities, qualifications, and supervision;
- Documentation of all required training, including training regarding privacy and confidentiality requirements, and the signed statement of the individual indicating the date, time, and place he or she received said training and the topics discussed, including the name and title of presenters;

- Documentation of periodic performance evaluations;
- A record of any disciplinary action taken;
- Notice of completed responsible vendor and eight-hour related duty training;
- Results of initial background investigation, including CORI reports; and
- Documentation of all security related events (including violations) and the results of any investigations and description of remedial actions, restrictions, or additional training required as a result of an incident.

Personnel records will be kept in a secure location to maintain confidentiality and be only accessible to the agent's manager or members of the executive management team.

Staffing Plan and Business Hours

Hiring and Recruitment

Sanctuary's Human Resource Manager will engage the executive management team and management staff on a regular basis to determine if vacancies are anticipated or whether specific positions need to be created in response to company needs. Sanctuary's hiring practices will include but are not limited to the following and apply to all types of working situations including hiring, firing, promotions, harassment, training, wages and benefits:

- Equal Employment Opportunity Commission (EEOC) Compliance;
- Sanctuary's Diversity Plan and Community Initiatives;
- Sanctuary's Plan to Positively Impact Areas of Disproportionate Impact;
- Background Checks and References;
- Mandatory reporting of criminal convictions (and termination if necessary);
- State and Federal Family Leave Act;
- Workplace Safety Laws;
- State and Federal Minimum Wage Requirements; and
- Non-Disclosure and Non-Complete Agreements

Standards of Conduct

Sanctuary is committed to maintaining an environment conducive to the health and wellbeing of customers and employees. It is Sanctuary's mission to provide a professional workplace free from harassment and discrimination for employees. Sanctuary will not tolerate harassment or discrimination on the basis of sex, race, color, national origin, age, religion, disability, sexual orientation, gender identity, gender expression, or any other trait or characteristic protected by any applicable federal, state, or local law or ordinance. Harassment or discrimination on the basis of any protected trait or characteristic is contrary to Sanctuary's values and is a violation of the Company Code of Conduct. Harassment is a form of discrimination. There is a broad range of behavior that could constitute harassment. In general, harassment is any verbal or physical conduct that:

- Has the purpose or effect of creating an intimidating, hostile, or offensive working environment;
- Has the purpose or effect of unreasonably interfering with an individual's work performance; or
- Adversely affects an individual's employment opportunities.

Employees are expected to maintain the highest degree of professional behavior. All harassment or discrimination by employees is strictly prohibited. Further, harassing or discriminatory behavior of non-employees directed at Sanctuary employees or customers also is condemned and will be promptly addressed.

Violence and Weapons in the Workplace

Any and all acts of violence in the workplace will result in immediate dismissal of the employee, customer, or parties involved. Law enforcement will be contacted immediately in the case of a violent event. Weapons are not permitted on site by employees, customers, or other parties. Employees found carrying weapons on Sanctuary facilities will be immediately terminated. Customers found carrying weapons on the premises will be asked to leave and/or the police will be notified accordingly.

At-Will Employment

In the state of Massachusetts, employment is assumed to be at-will unless otherwise stated. At-will employment implies that employer and employee alike may terminate the work relationship at any given moment and for any legitimate purpose. Wrongful termination may be more difficult to prove in an at-will arrangement because of the freedom that each party has to end the employment. However, there are still many instances wherein a termination or discharge can be called wrongful, even in an at-will employment.

Workplace Attire

The required attire for registered agents at Sanctuary varies based upon required duties. New hire training and the onboarding process will go over the workplace attire specific to each role and the department manager will be responsible for ensuring compliance with all requirements is met.

Overview of Personnel Policies and Procedures

Standard Employment Practices

Sanctuary values the contributions of its management and staff positions. Sanctuary will strive to be the industry leader in workplace satisfaction by offering highly competitive wage and benefits packages and developing a culture that values a proper work-life balance, boasts a transparent and accessible executive management team, and fosters a work ethic that focuses on the mission of the company and spirit of the adult-use marijuana program in Massachusetts.

Advancement

The organization will be structured in a relatively flat manner, with promotional opportunities within each department. Participation in training and bi-annual performance evaluations will be critical for any promotions or pay increases.

Written Policies

Sanctuary's written policies will address, inter alia, the Family and Medical Leave Act (FMLA), the Consolidated Omnibus Budget Reconciliation Act (COBRA), equal employment opportunity, discrimination, harassment, the Employee Retirement Income Security Act (ERISA), disabilities, maintenance of personnel files, privacy, email policy, 935 CMR 500.000 et. seq., holidays, hours, sick time, personal time, overtime, performance reviews, disciplinary procedures, working hours, pay rates, overtime, bonuses, veteran preferences, drug testing, personnel policies, military leaves of absence, bereavement leave, jury duty, CORI checks, smoking, HIPAA, patient confidentiality, and compliance hotline.

Investigations

Sanctuary will set forth policies and procedures to investigate any complaints or concerns identified or raised internally or externally in order to stay in compliance with 935 CMR 500.000 et. seq.

Designated Outside Counsel

Sanctuary may retain counsel specializing in employment law to assist the Human Resources Manager with any issues and questions.

Job Status

Job Classifications

Positions at Sanctuary are categorized by rank and by department. The executive management team oversees the overall success of mission of the company; the CEO is responsible for implementation of the mission and the executive management team as a whole is responsible for ensuring that all departments are properly executing their functions and responsibilities. Job classification is comprised of three rank tiers: Executive Management, Management, and Non-Management Employee.

Work Schedules

Work schedules will be either part-time, full-time, or salaried, depending of the specific position. Schedules will be set according to the needs of each department as determined by the department manager and the executive manager they report to. It is the department manager's responsibility to develop and implement a work schedule that provides necessary duty and personnel coverage but does not exceed what is required for full implementation of operations. It is also the department manager's responsibility to ensure that adequate coverage occurs on a daily basis and does not lead to unnecessary utilization of overtime coverage.

Mandatory Meetings and Community Service Days

There will be a mandatory reoccurring company-wide meeting on a monthly basis. All required personnel will be notified of their required attendance. Certain personnel, such as house-keeping staff, may not be required to attend. Each department will have a mandatory weekly meeting schedule by the department manager. The department managers will provide agendas for all meeting and will report to their executive manager.

Breaks

Daily breaks, including lunch breaks, will comply with the laws of the Commonwealth.

Performance Reviews

Performance reviews will be conducted by executive or department managers. Reviews will be conducted at three-month intervals for new employees during the first year and at 6-month intervals thereafter. A written synopsis must be provided to, and signed by, the employee under review. Reviews must be retained in each employee's employment file. Performance reviews must take into account positive performance factors and areas requiring improvement. Scoring systems may be utilized to help reflect the employee's overall performance.

Leave Policies

Sanctuary leave policies will comport with all state and federal statutes.

All full-time employees will receive two 40-hour weeks of paid vacation per annum. Additional leave must be requested at least 2 weeks in advance and approved by the employee's department manager. Sanctuary will determine which holidays will be observed and which departments will not be required to work. Sanctuary will offer paid maternity leave. Additional leave will not be paid and must be approved by the department manager.

Sanctuary anticipates observing the following holidays:

- New Year's Day;
- Martin Luther King Day;
- Presidents' Day;
- Memorial Day;
- Independence Day;
- Labor Day;
- Thanksgiving; and
- Christmas Day.

Disciplinary Policies

Purpose

Sanctuary's discipline policy and procedure is designed to provide a structured corrective action process to improve and prevent a recurrence of undesirable behavior and/or performance issues. The steps outlined below of Sanctuary's discipline policy and procedure have been designed consistent with Sanctuary's organizational values, best practices, and employment laws.

Sanctuary reserves the right to combine or skip steps depending upon facts of each situation and the nature of the offense. The level of disciplinary intervention may also vary. Some of the factors that will be considered depend upon whether the offense is repeated despite coaching,

counseling, and/or training; the employee's work record; and the impact the conduct and performance issues have on Sanctuary's organization.

Procedure

Step 1: Counseling and Verbal Warning

Step 1 creates an opportunity for the immediate supervisor to schedule a meeting with an employee to bring attention to the existing performance, conduct, or attendance issue. The supervisor should discuss with the employee the nature of the problem or violation of company policies and procedures. The supervisor is expected to clearly outline expectations and steps the employee must take to improve performance or resolve the problem.

Within five business days, the supervisor will prepare written documentation of a Step 1 meeting. The employee will be asked to sign the written documentation. The employee's signature is needed to demonstrate the employee's understanding of the issues and the corrective action needed.

Step 2: Written Warning

While it is hoped that the performance, conduct, or attendance issues that were identified in Step 1 have been corrected, Sanctuary recognizes that this may not always be the case. A written warning involves a more formal documentation of the performance, conduct, or attendance issues and consequences.

During Step 2, the immediate supervisor and a department manager or director will meet with the employee and review any additional incidents or information about the performance, conduct, or attendance issues as well as any prior relevant corrective action plans. Management will outline the consequences for the employee of his or her continued failure to meet performance and/or conduct expectations. A formal performance improvement plan (PIP) requiring the employee's immediate and sustained corrective action will be issued within five business days of a Step 2 meeting. A warning outlining that the employee may be subject to additional discipline up to and including termination if immediate and sustained corrective action is not taken may also be included in the written warning.

Step 3: Suspension and Final Written Warning

There may be performance, conduct, or safety incidents so problematic and harmful that the most effective action may be the temporary removal of the employee from the workplace. When immediate action is necessary to ensure the safety of the employee or others, the immediate supervisor may suspend the employee pending the results of an investigation.

Suspensions that are recommended as part of the normal progression of this progressive discipline policy and procedure are subject to approval from a next-level manager and the Human Resources Manager.

Depending upon the seriousness of the infraction, the employee may be suspended without pay in full-day increments consistent with federal, state and local wage-and-hour employment laws. Nonexempt/hourly employees may not substitute or use an accrued paid vacation or sick day in lieu of the unpaid suspension. Due to Fair Labor Standards Act (FLSA) compliance issues, unpaid suspension of salaried/exempt employees is reserved for serious workplace safety or conduct issues. The Human Resources Manager will provide guidance so that the discipline is administered without jeopardizing the FLSA exemption status.

Pay may be restored to the employee if an investigation of the incident or infraction absolves the employee.

Step 4: Recommendation for Termination of Employment

The last and most serious step in the progressive discipline procedure is a recommendation to terminate employment. Generally, Sanctuary will try to exercise the progressive nature of this policy by first providing warnings, a final written warning, and/or suspension from the workplace before proceeding to a recommendation to terminate employment. However, Sanctuary reserves the right to combine and skip steps depending upon the circumstances of each situation and the nature of the offense. Furthermore, employees may be terminated without prior notice or disciplinary action.

Management's recommendation to terminate employment must be approved by the Human Resources Manager and department manager or designee. Final approval may be required from the CEO or designee.

Nothing in this policy provides any contractual rights regarding employee discipline or counseling nor should anything in this policy be read or construed as modifying or altering the employment-at-will relationship between Sanctuary and its employees.

Appeal Process

Employees will have the opportunity to present information that may challenge information management has used to issue disciplinary action. The purpose of this process is to provide insight into extenuating circumstances that may have contributed to the employee performance and/or conduct issues while allowing for an equitable solution.

If the employee does not present this information during any of the step meetings, he or she will have five business days after that meeting to present information.

Performance and Conduct Issues Not Subject to Progressive Discipline

Behavior that is illegal is not subject to progressive discipline and may be reported to local law enforcement. Theft, intoxication at work, fighting and other acts of violence are also not subject to progressive discipline and may be grounds for immediate termination.

Documentation

The employee will be provided copies of all progressive discipline documentation, including all performance improvement plans. The employee will be asked to sign copies of this documentation attesting to their receipt and understanding of the corrective action outlined in these documents. Copies of these documents will be placed in the employee's official personnel file.

Separation of Employment

Separation of employment within an organization can occur for several different reasons. Employment may end as a result of resignation, retirement, release (end of season or assignment), reduction in workforce, or termination. When an employee separates from Sanctuary, his or her supervisor must contact the Human Resources Manager to schedule an exit interview, typically to take place on employee's last workday.

Types of Separation

1. Resignation

Resignation is a voluntary act initiated by the employee to end employment with Sanctuary. The employee must provide a minimum of two (2) weeks' notice prior to resignation. If an employee does not provide advance notice or fails to actually work the remaining two weeks, the employee will be ineligible for rehire and will not receive accrued benefits. The resignation date must not fall on the day after a holiday.

2. Retirement

An employee who wishes to retire is required to notify his or her department director and the Human Resources Manager in writing at least one (1) month before planned retirement date. It is the practice of Sanctuary to give special recognition to employees at the time of their retirement.

3. Job Abandonment

An employee who fails to report to work or contact his or her supervisor for two (2) consecutive workdays will be considered to have abandoned the job without notice effective at the end of the employee's normal shift on the second day. The department manager will notify the Human Resources Manager at the expiration of the second workday and initiate the paperwork to terminate the employee. Employees who are separated due to job abandonment are ineligible to receive accrued benefits and are ineligible for rehire.

4. Termination

Employees of Sanctuary are employed on an at-will basis, and the company retains the right to terminate an employee at any time.

5. Reduction in Workforce

An employee may be laid off due to changes in duties, organizational changes, lack of funds, or lack of work. Employees who are laid off may not appeal the layoff decision through the appeal process.

6. Release

Release is the end of temporary or seasonal employment. The Human Resources Manager, in consultation with the department manager, will inform the temporary or seasonal worker of their release according to the terms of the individual's temporary employment.

Exit Interview

The separating employee will contact the HR department as soon as notice is given to schedule an exit interview. The interview will be on the employee's last day of work or other day, as mutually agreed upon.

Return of Property

The separating employee must return all company property at the time of separation, including but not limited to uniforms, cell phones, keys, computers, and identification cards. Failure to return some items may result in deductions from final paycheck. An employee will be required to sign the Wage Deduction Authorization Agreement to deduct the costs of such items from the final paycheck.

Termination of Benefits

An employee separating from Sanctuary is eligible to receive benefits as long as the appropriate procedures are followed as stated above. Two weeks' notice must be given, and the employee must work the full two work weeks. Accrued vacation leave will be paid in the last paycheck. Accrued sick leave will be paid in the last paycheck.

Health Insurance

Health insurance terminates on the last day of the month of employment, unless employee requests immediate termination of benefits. Information about the Consolidated Omnibus Budget Reconciliation Act (COBRA) continued health coverage will be provided. Employees will be required to pay their share of the dependent health and dental premiums through the end of the month.

Rehire

Former employees who left in good standing and were classified as eligible for rehire may be considered for reemployment. An application must be submitted to the Human Resources Manager, and the applicant must meet all minimum qualifications and requirements of the position, including any qualifying exam, when required.

Department managers must obtain approval from the Human Resources Manager or designee prior to rehiring a former employee. Rehired employees begin benefits just as any other new employee. Previous tenure will not be considered in calculating longevity, leave accruals, or any other benefits.

An applicant or employee who is terminated for violating policy or who resigned in lieu of termination from employment due to a policy violation will be ineligible for rehire.

Compensation

As an employer, Sanctuary believes that it is in the best interest of both the organization and Sanctuary's employees to fairly compensate its workforce for the value of the work provided. It is Sanctuary's intention to use a compensation system that will determine the current market value of a position based on the skills, knowledge, and behaviors required of a fully-competent incumbent. The system used for determining compensation will be objective and non-discriminatory in theory, application and practice. The company has determined that this can best be accomplished by using a professional compensation consultant, as needed, and a system recommended and approved by the executive management team.

Selection Criteria

1. The compensation system will price positions to market by using local, national, and industry specific survey data.
2. The market data will primarily include marijuana-related businesses and will include survey data for more specialized positions and will address significant market differences due to geographical location.
3. The system will evaluate external equity, which is the relative marketplace job worth of every marijuana industry job directly comparable to similar jobs at Sanctuary, factored for general economic variances, and adjusted to reflect the local economic marketplace.
4. The system will evaluate internal equity, which is the relative worth of each job in the organization when comparing the required level of job competencies, formal training and experience, responsibility and accountability of one job to another, and arranging all jobs in a formal job-grading structure.
5. Professional support and consultation will be available to evaluate the compensation system and provide on-going assistance in the administration of the program.
6. The compensation system must be flexible enough to ensure that the company is able to recruit and retain a highly-qualified workforce, while providing the structure necessary to effectively manage the overall compensation program.

Responsibilities

The executive management team and will give final approval for the compensation system that will be used by Sanctuary.

1. On an annual basis the executive management team will review and approve, as appropriate, recommended changes to position-range movement as determined through the vendor's market analysis process.
2. As part of the annual budgeting process, the executive management team will review and approve, as appropriate, funds to be allocated for total compensation, which would include base salaries, bonus, variable based or incentive-based pay, and all other related expenses, including benefit plans.

Management Responsibility

1. The CEO is charged with ensuring that Sanctuary is staffed with highly-qualified, fully-competent employees and that all programs are administered within appropriate guidelines and within the approved budget.
2. The salary budget will include a gross figure for the following budget adjustments, but the individual determinations for each employee's salary adjustment will be the exclusive domain of the CEO: determining the appropriate head count, titles, position levels, merit

and promotional increases and compensation consisting of salary, incentive, bonus, and other discretionary pay for all positions.

3. The CEO will ensure that salary ranges are updated at least annually, that all individual jobs are market priced at least once every two years, and that pay equity adjustments are administered in a fair and equitable manner.

Agent Background Checks

- In addition to completing the Commission's agent registration process, all agents hired to work for Sanctuary will undergo a detailed background investigation prior to being granted access to a Sanctuary facility or beginning work duties.
- Background checks will be conducted on all agents in their capacity as employees or volunteers for Sanctuary pursuant to 935 CMR 500.100 and will be used by the Director of Security, who will be registered with the Department of Criminal Justice Information Systems pursuant to 803 CMR 2.04: iCORI Registration and the Commission for purposes of determining the suitability of individuals for registration as a marijuana establishment agent with the licensee.
- For purposes of determining suitability based on background checks performed in accordance with 935 CMR 500.101(1), Sanctuary will consider:
 - a. All conditions, offenses, and violations are construed to include Massachusetts law or like or similar law(s) of another state, the United States or foreign jurisdiction, a military, territorial or Native American tribal authority, or any other jurisdiction.
 - b. All criminal disqualifying conditions, offenses, and violations include the crimes of attempt, accessory, conspiracy, and solicitation. Juvenile dispositions will not be considered as a factor for determining suitability.
 - c. Where applicable, all look back periods for criminal conditions, offenses, and violations included in 935 CMR 500.802 commence upon the date of disposition; provided, however, that if disposition results in incarceration in any institution, the look back period will commence upon release from incarceration.
- Suitability determinations will be made in accordance with the procedures set forth in 935 CMR 500.800. In addition to the requirements established in 935 CMR 500.800, Sanctuary will:
 - a. Comply with all guidance provided by the Commission and 935 CMR 500.802: Tables B through D to determine if the results of the background are grounds for Mandatory Disqualification or Presumptive Negative Suitability Determination.
 - b. Consider whether offense(s) or information that would result in a Presumptive Negative Suitability Determination under 935 CMR 500.802. In the event a Presumptive Negative Suitability Determination is made, Sanctuary will consider the following factors:
 - i. Time since the offense or incident;
 - ii. Age of the subject at the time of the offense or incident;
 - iii. Nature and specific circumstances of the offense or incident;
 - iv. Sentence imposed and length, if any, of incarceration, if criminal;
 - v. Penalty or discipline imposed, including damages awarded, if civil or administrative;

- vi. Relationship of offense or incident to nature of work to be performed;
 - vii. Number of offenses or incidents;
 - viii. Whether offenses or incidents were committed in association with dependence on drugs or alcohol from which the subject has since recovered;
 - ix. If criminal, any relevant evidence of rehabilitation or lack thereof, such as information about compliance with conditions of parole or probation, including orders of no contact with victims and witnesses, and the subject's conduct and experience since the time of the offense including, but not limited to, professional or educational certifications obtained; and
 - x. Any other relevant information, including information submitted by the subject.
 - c. Consider appeals of determinations of unsuitability based on claims of erroneous information received as part of the background check during the application process in accordance with 803 CMR 2.17: Requirement to Maintain a Secondary Dissemination Log and 2.18: Adverse Employment Decision Based on CORI or Other Types of Criminal History Information Received from a Source Other than the DCJIS.
- Upon adverse determination, Sanctuary will provide the applicant a copy of their background screening report and a pre-adverse determination letter providing the applicant with a copy of their right to dispute the contents of the report, who to contact to do so and the opportunity to provide a supplemental statement.
 - After 10 business days, if the applicant is not disputing the contents of the report and any provided statement does not alter the suitability determination, an adverse action letter will be issued providing the applicant information on the final determination made by Sanctuary along with any legal notices required.
- All suitability determinations will be documented in compliance with all requirements set forth in 935 CMR 500 et seq. and guidance provided by the Commission.
- Background screening will be conducted by an investigative firm holding the National Association of Professional Background Screeners (NAPBS®) Background Screening Credentialing Council (BSCC) accreditation and capable of performing the searches required by the regulations and guidance provided by the Commission.
- References provided by the agent will be verified at the time of hire.
- As deemed necessary, individuals in key positions with unique and sensitive access (e.g. members of the executive management team) will undergo additional screening, which may include interviews with prior employers or colleagues.
- As a condition of their continued employment, agents, volunteers, contractors, and subcontractors are required to renew their Program ID cards annually and submit to other background screening as may be required by Sanctuary or the Commission.

Plan for Separating Recreational from Medical Operations

Currently, Sanctuary Medicinals, Inc. does not intend to co-locate medical and adult-use operations at its proposed Brookline retail facility. Should this change in the future, SM will update the Commission accordingly and receive any such approvals necessary to co-locate its medical and adult-use operations in Brookline. At such a time, Sanctuary will separate its medical and adult-use operations in Brookline according to the following procedures:

Sanctuary Medicinals, Inc. (“Sanctuary”) has developed plans to ensure virtual and physical separation between medical and adult use marijuana operations in accordance with 935 CMR 500.101(2)(e)(4).

Using a sophisticated and customized seed-to-sale and Point of Sale (POS) software system approved by the Commission, Sanctuary will virtually separate medical and adult-use operations by designating at the point of sale whether a particular marijuana product is intended for sale to a registered patient/caregiver or a verified consumer 21 years of age or older. All inventory and sales transactions will be carefully tracked and documented in these software systems.

In compliance with 935 CMR 500.140(10), Sanctuary will ensure that registered patients have access to a sufficient quantity and variety of marijuana and marijuana products to meet their medical needs. For the first 6 months of operations, 35% of Sanctuary’s marijuana product inventory will be marked for medical use and reserved for registered patients. Thereafter, a quantity and variety of marijuana products for patients that is sufficient to meet the demand indicated by an analysis of sales data collected during the preceding 6 months will be marked and reserved for registered patients.

Marijuana products reserved for registered patients will be either: (1) maintained on site in an area separate from marijuana products intended for adult use, or (2) easily accessible at another Sanctuary location and transferable to Sanctuary’s retailer location within 48 hours. Sanctuary may transfer a marijuana product reserved for medical use to adult use within a reasonable period of time prior to the product’s date of expiration.

In addition to virtual separation, Sanctuary will provide for physical separation between the area designated for sales of medical marijuana products to patients/caregivers, and the area designated for sales of adult-use marijuana products to individuals 21 years of age or older. Within the sales area, a temporary or semi-permanent barrier, such as a stanchion or other divider, will be installed to create separate, clearly marked lines for patients/caregivers and adult-use consumers. Trained marijuana establishment agents will verify the age of all individuals, as well the validity of any Medical Use of Marijuana Program ID Cards, upon entry to the facility and direct them to the appropriate queue.

Access to the adult-use marijuana queue will be limited to individuals 21 years of age or older, regardless if the individual is registered as a patient/caregiver. Registered patients under the age of 21 will only have access to the medical marijuana queue. Registered patients/caregivers 21 years of age or older will be permitted to access either queue and will not be limited only to the medical marijuana queue.

Sanctuary will have a private area separate from the sales floor to allow a registered patient/caregiver to meet with a trained marijuana establishment agent for confidential consultations about the medical use of marijuana.

TODAY	101	102	103	104	105	106	107	108	Mom	
Racks	6	7	7	7	6	8	8	8	4	
Tiers	3	3	3	3	3	2	2	3	2	
SF per rack	166	166	166	166	166	166	166	166	4	
Canopy Square Footage per Room	2,988	3,486	3,486	3,486	2,988	2,656	2,656	3,984	1,024	Total Canopy Square Feet
LED (569 Watts MAX)	57	68	68	68	121	80	80	234	0	441544
CMH (630 Watts MAX)	114	138	138	138	55	80	80	0	62	489849
Total Lights	171	206	206	206	176	160	160	234	62	931,393
HLPD										34.8

Notes:
 On average, only first tier of lights are on for the first 14 days of the plants lifecycle, then all tiers are on until trays are harvested
 On average, CMH are dimmed to 354 watts until about Day 14 of plant lifecycle, then lights are full blast until harvest (on average of about 63 days)
 On average, LEDs are ramped from 30% to 100% from day 14 to 21 of the plants lifecycle, prior to this, LEDs are off, as plants are only on first tier under CMH for first 14 days of their life
 Note: Partial of the mother room lights are 315 watt, partial are able to hit 630 watts, however, all lights are set to max 315 watts at all times

BLW ENGINEERS, INC.

MEMORANDUM

DATE: September 8, 2020

TO: Cannabis Control Commission

FROM: Erik M. Gath, PE - BLW Engineers

PROJECT: Sanctuary Medicinals
234 Taylor Street, Littleton, MA

SUBJECT: HVAC & Dehumidification Systems

COPIES TO: Sanctuary Medicinals

BLW has designed the HVAC and dehumidification systems in accordance with Massachusetts Building Code, and the HVAC and dehumidification equipment have been evaluated and sized for the loads of the facility.

The facility utilizes (2) 300-ton high efficiency chillers and (2) 1999 MBH boilers for all heating, cooling, and dehumidification purposes. Piping is distributed throughout the facility to air handling units for each room. Flower rooms utilize energy recovery air handling units for dehumidification.

Attached are the equipment schedules and equipment data.



HVAC SCHEDULES:



BLW Engineers, Inc.

311 Great Road, Post Office Box 1551
Littleton, Massachusetts 01460
T: 978.486.4301 F: 978.428.0067
www.blwengineers.com

HVAC * ELECTRICAL * PLUMBING * FIRE PROTECTION

ENERGY RECOVERY UNIT SCHEDULE																												
TAG	SERVICE	MANUFACTURER	MODEL #	SUPPLY FAN DATA						ENERGY RECOVERY SECTION						DEHUMIDIFICATION COIL						ACCESSORIES/COMMENTS						
				TOTAL CFM	FAN CFM	ESP (" W.C.)	RPM	BRAKE HP	FAN HP	FAN QTY	SUPPLY AIR			RETURN AIR			SUPPLY AIR			COIL DATA								
				TYPE	EAT(°F) DB/WB	LAT(°F) DB/WB	PD (" W.C.)	EAT(°F) DB/WB	LAT(°F) DB/WB	TYPE	EAT(°F) DB/WB	LAT(°F) DB/WB	PD (" W.C.)	TOTAL	SENS.	GPM	EWT/LWT	WPD	ROWS	FPI								
ERU-1A,1B,2A,2B,3A,3B,4A,4B,5A,5B	PLANT ROOMS 101 THRU 105	INNOVENT	LASER-1-OU-PL-12000-CH-WH-460	12000	12000	2.0	2353	9.2	15	2	PLATE	78.0/63.5	58.2/56.4	1.54	46.5/46.5	66.2/55.1	30% GLYCOL	58.2/56.4	46.5/46.5	1.56	308.2	154.8	94	40/47	14.8"	8	11	SECURIAIRE MERV 15 FILTER SECTION OUTDOOR AIR DAMPER SUPPLY FAN PLATE HEAT EXCHANGER DISCONNECT VFD
ERU-6,7,8	PLANT ROOMS 106 THRU 109	INNOVENT	LASER-1-OU-PL-12000-CH-WH-460	12000	12000	2.0	2353	9.2	15	2	PLATE	78.0/63.5	58.2/56.4	1.54	46.5/46.5	66.2/55.1	30% GLYCOL	58.2/56.4	46.5/46.5	1.56	308.2	154.8	94	40/47	14.8"	8	11	

WATER COOLED CHILLER SCHEDULE																	
TAG No.	LOCATION (S)	MANUFACTURER	MODEL	TYPE	EVAPORATOR DATA					ELECTRICAL DATA				WEIGHT (LBS)	REMARKS		
					EWT °F	LWT °F	GPM	WPD (FT)	TOTAL COOLING TONS	VOLTS	PHASE	HZ	MCA			MOCOP	
CH-1,2	OUTDOORS	DAIKIN	AWV020A	AIR COOLED	47	40	1068	24.8	294.0	460	3	60	541	600	20612	PROVIDE WITH PUMP SET PACKAGE, BUFFER TANK, AND PACKAGED CONTROLLER	

AIR HANDLING UNIT SCHEDULE																										
TAG No.	LOCATION	MANUFACTURER	MODEL No./SIZE (AS STANDARD)	TYPE	COOLING DATA						HEATING DATA						FAN DATA				ELECTRICAL DATA				WEIGHT (LBS)	REMARKS
					MBH TOTAL	SENS.	EAT °F DB/WB	WTD EWT/LWT	GPM	WPD (FT)	MBH TOTAL	EAT DEF	LAT DEF	EWT DEF	GPM	WPD (FT)	CFM	OA MINIMUM (W.C.)	ESP (" W.C.)	VOLTS	PHASE	HP				
AHU-1A	GENERAL STORAGE	DAIKIN	HHB	HORIZONTAL BLOWER	36.0	26.0	76/64	40/50	8.0	4.0	60.4	55	95	160	120	4.0	1500	120	0.5	120	1	1	240	PROVIDE WITH ECM MOTOR, CONDENSATE OVERFLOW SWITCH, DISCONNECT, FREEZE STAT		
AHU-1B	GENERAL STORAGE	DAIKIN	HHB	HORIZONTAL BLOWER	36.0	26.0	76/64	40/50	8.0	4.0	32.5	55	75	160	120	4.0	1200	120	0.5	120	1	1/3	181	PROVIDE WITH ECM MOTOR, CONDENSATE OVERFLOW SWITCH, DISCONNECT, FREEZE STAT		
AHU-2A,2B	DRY ROOM	DAIKIN	LAH	HORIZONTAL BLOWER	45.0	35.0	75/63	40/47.8	11.0	5.5	52.0	55	86.7	160	120	3.0	1500	150	0.5	460	3	2	432	PROVIDE WITH HOT WATER COIL SHALL BE IN REHEAT POSITION		
AHU-3	PROCESS/TRAINING	DAIKIN	HHB	HORIZONTAL BLOWER	36.0	26.0	76/64	40/50	8.0	4.0	60.4	55	95	160	120	4.0	1200	120	0.5	120	1	1/3	181	PROVIDE WITH ECM MOTOR, CONDENSATE OVERFLOW SWITCH, DISCONNECT, FREEZE STAT		
AHU-4	LAB	DAIKIN	HHB	HORIZONTAL BLOWER	36.0	26.0	76/64	40/50	8.0	4.0	60.4	55	95	160	120	4.0	1200	120	0.5	120	1	1/3	181	PROVIDE WITH ECM MOTOR, CONDENSATE OVERFLOW SWITCH, DISCONNECT, FREEZE STAT		
AHU-5	KITCHEN	DAIKIN	HHB	HORIZONTAL BLOWER	160.7	75.4	88/74	40/50	32.2	4.0	203.1	55	85	160	120	20.0	2400	2400	0.5	460	3	2.0	589	PROVIDE WITH ECM MOTOR, CONDENSATE OVERFLOW SWITCH, DISCONNECT, FREEZE STAT		
AHU-6	SECURE STORAGE	DAIKIN	HHB	HORIZONTAL BLOWER	36.0	26.0	76/64	40/50	8.0	4.0	60.4	55	95	160	120	4.0	1200	120	0.5	120	1	1/3	181	PROVIDE WITH ECM MOTOR, CONDENSATE OVERFLOW SWITCH, DISCONNECT, FREEZE STAT		
AHU-7	SHIPPING RECEIVING	DAIKIN	HHB	HORIZONTAL BLOWER	60.0	43.2	76/64	40/50	12.0	4.0	69.2	58	90	160	120	7.0	2000	200	0.5	460	3	3	473	PROVIDE WITH ECM MOTOR, CONDENSATE OVERFLOW SWITCH, DISCONNECT, FREEZE STAT		
AHU-8	BUILDING CORE	DAIKIN	OA	HORIZONTAL BLOWER	160.4	102.8	78/67	40/50	33.0	4.0	121.4	55	82.8	160	120	7.0	4000	800	1.0	460	3	3.5	2191	PROVIDE WITH SECURE/FILTRATION SYSTEM HOT WATER COIL SHALL BE IN REHEAT POSITION		
AHU-9	BUILDING CORE	DAIKIN	OA	HORIZONTAL BLOWER	160.4	102.8	78/67	40/50	33.0	4.0	121.4	55	82.8	160	120	7.0	4000	800	1.0	460	3	3.5	2191	PROVIDE WITH SECURE/FILTRATION SYSTEM HOT WATER COIL SHALL BE IN REHEAT POSITION		
AHU-10	MOTHER	DAIKIN	HHB	HORIZONTAL BLOWER	60.0	43.2	76/64	40/50	12.0	4.0	69.2	58	90	160	120	7.0	2000	200	0.50	460	3	3	473	PROVIDE WITH ECM MOTOR, CONDENSATE OVERFLOW SWITCH, DISCONNECT, FREEZE STAT		
AHU-11	MOTHER	DAIKIN	HHB	HORIZONTAL BLOWER	60.0	43.2	76/64	40/50	12.0	4.0	69.2	58	90	160	120	7.0	2000	200	0.50	460	3	3	473	PROVIDE WITH ECM MOTOR, CONDENSATE OVERFLOW SWITCH, DISCONNECT, FREEZE STAT		
AHU-12	CLONE	DAIKIN	HHB	HORIZONTAL BLOWER	36.0	26.0	76/64	40/50	8.0	4.0	60.4	55	95	160	120	4.0	1200	120	0.5	120	1	1/3	181	PROVIDE WITH ECM MOTOR, CONDENSATE OVERFLOW SWITCH, DISCONNECT, FREEZE STAT		

- NOTE: 1. ALL FAN COIL UNITS SHALL BE PROVIDED WITH ECM MOTOR.
- 2. ALL FAN COIL UNITS SHALL BE SINGLE POINT POWER CONNECTION.
- 3. BALANCER TO ADJUST AIRFLOWS ACCORDING TO SUPPLY OUTLET TOTALS ON PLANS.
- 4. PROVIDE LITTLE GIANT CONDENSATE PUMP, HIGH CAPACITY MODEL, 120/1/60.

BOILER SCHEDULE													
TAG No.	LOCATION(S)	MANUFACTURER (AS STANDARD)	MODEL (AS STANDARD)	TYPE	GROSS OUTPUT MBH	NET I=B+R MBH	BURNER INPUT MBH	MIN GAS PRES IN WC	ELECTRICAL DATA			REMARKS	
									VOLTS	PHASE	AMPS		
B-1,2	BOILER ROOM	LOCHNAR	FB2001	CONDENSING	1924	1673	1999	4"	120	1	13.0	PROVIDE CONTROLS, BOILER PUMPS, LOW WATER CUTOFF, DRAIN ACID NEUTRALIZER	

FLUID COOLER SCHEDULE																				
TAG No.	LOCATION (S)	MANUFACTURER	MODEL No.	TYPE	CONDENSING DATA						ELECTRICAL DATA				WEIGHT (LBS)	REMARKS				
					CFM	EAT °F WB	EWT °F	LWT °F	GPM	TOTAL COOLING MBH	VOLTS	PHASE	HZ	TOWER FAN #			H.P.	FLA	MCA	MOCOP
FC-1,2	SITE	CANCOIL	VFCS-16-4C-2	FLUID COOLER	---	30	52	42	690	2863.4	460	3	HZ	16	1	64	80	100	15121	

EXPANSION TANK SCHEDULE								
TAG No.	SYSTEM SERVED	MANUFACTURER (AS STANDARD)	MODEL No. (AS STANDARD)	TYPE	TANK VOLUME GALLONS	ACCEPTANCE VOLUME GALLONS	DIMENSIONS DIAMETER x HEIGHT	WEIGHT LBS
ET-1	CHILLED WATER	TACO	CA300	BLADDER	79	79	24" x 57-3/4"	330
ET-2	HOT WATER	TACO	CA80	BLADDER	211	211	30" x 89-7/8"	590

PUMP SCHEDULE											
TAG No.	SERVICE	MANUFACTURER (AS STANDARD)	MODEL No. (AS STANDARD)	TYPE	PUMP DATA			ELECTRICAL DATA			REMARKS
					GPM	RPM	HEAD(FT)	VOLTS	PHASE	HP	
CP-1A,1B CP-2A,2B	CHILLER PUMPS	TACO	FB090C	END SUCTION	1070	1750	40	460	3	20	PROVIDE DISCONNECT, VARIABLE FREQUENCY DRIVES, 30% PROPYLENE GLYCOL
P-1A,1B	CHILLED WATER	TACO	FB013	END SUCTION	2140	1750	115	460	3	100	PROVIDE DISCONNECT, VARIABLE FREQUENCY DRIVES, 30% PROPYLENE GLYCOL
BP-1BP-2	BOILER PUMPS	TACO	1935	IN-LINE	100	1750	10	460	3	3/4	PROVIDE DISCONNECT
P-2A,2B	HOT WATER	TACO	FD507D	END SUCTION	200	1750	40	460	3	3	PROVIDE DISCONNECT, VARIABLE FREQUENCY DRIVES, 30% PROPYLENE GLYCOL

DRAIN PUMP SCHEDULE											
TAG No.	SERVICE	MANUFACTURER (AS STANDARD)	MODEL No. (AS STANDARD)	TYPE	PUMP DATA			ELECTRICAL DATA			REMARKS
					GPM	RPM	HEAD(FT)	VOLTS	PHASE	HP	
DP-1	AHU DRAINS	LITTLE GIANT	3-ABS	CONDENSATE REMOVAL	1	1750	20'	120	1	1/12	PROVIDE DISCONNECT

ELECTRIC STEAM GENERATOR											
TAG No.	LOCATION(S)	MANUFACTURER (AS STANDARD)	MODEL No. (AS STANDARD)	TYPE	CAPACITY GPM	RECOVERY DEMAND	FLOW TEMPERATURE	VOLTS	PHASE	AMPS	REMARKS
ES-1		PHI-STEAM	ESP-017	ELECTRODE	50	-	400	460	3	20	UNIT TO BE PROVIDED WITH STEAM BLOWER, CONTROLS, CONDENSATE PUMP, DISCONNECT

- NOTE: 1. ANTI-SKID METALL CONDENSATE PUMP (CP-1) MODEL S214, 120/1/60.
- 2. PROVIDE DRAIN KOOLER.

EQUIPMENT TO BE PURCHASED BY OWNER
CONTROLS BY MECHANICAL CONTRACTOR

EXHAUST FAN SCHEDULE											
TAG No.	MANUFACTURER	MODEL	CFM	ESP.	RPM	H.P.	#	VOLT	WEIGHT (LBS)	COMMENTS	
EF-1,2	GREENHECK	CUE-131-VG	1800	0.25	1450	1/2	1	120	73	---	PROVIDE CARBON FILTER BOX
KEF-1	CAPTIVEAIRE	DUSHFA	2400	0.5	1800	3/4	1	120	85	---	PROVIDE WALL MOUNTED SPEED CONTROL

PIPING SCHEDULE				
SERVICE	LOCATION	PIPING	FITTINGS	JOINTS
HYDRONIC HEATING CHILLED WATER 2-1/2" AND SMALLER		TYPE "L" SEAMLESS COPPER TUBING	WROUGHT COPPER	SWEAT SOLDER
3" AND LARGER		SCHEDULE 40 SEAMLESS BLACK STEEL	SCHEDULE 40 SEAMLESS BUTT WELDED	WELDED
DOMESTIC WATER	ABOVE GROUND	TYPE "L" COPPER	WROT COPPER, NO LEAD	95/5 NO-LEAD SOLDER
AHU DRAINS		TYPE "L" COPPER	WROT COPPER, NO LEAD	95/5 NO-LEAD SOLDER
REFRIGERANT PIPING		COPPER - ARC	COPPER, NO LEAD	BRAZED

INSULATION SCHEDULE					
LOCATION	INSULATION TYPE	FITTING INSULATION TYPE	FOR PIPE DIA (INCHES)		
			RUNOUTS	< 1 1/2"	2"-2 1/2"
HOT WATER SUPPLY & RETURN PIPING	FIBERGLASS WITH ALL SERVICE JACKET	ZESTON	1 1/2"	1 1/2"	2"
REFRIGERANT PIPING	ELASTOMERIC	ZESTON	1 1/2"	1 1/2"	---
OUTDOOR SUPPLY, RETURN & OUTSIDE AIR DUCT INSULATION	2" FIBERGLASS DUCT WRAP WITH FSK FACING	WEATHER TIGHT MIN. R-8			
SUPPLY RETURN INSULATION	NONE				
CHILLED WATER SUPPLY & RETURN & DRAIN PIPING	FIBERGLASS WITH ALL SERVICE JACKET	ZESTON	1/2"	1"	1"

OUTDOOR PIPING SHALL BE PROVIDED WITH WEATHERPROOF AND DAMAGE RESISTANT CLADDING

REGISTER, GRILLE & DIFFUSER SCHEDULE									
TAG	SERVICE	CFM	NECK SIZE	FRAME TYPE	MOUNTING	DAMPER	MATERIAL	FINISH	MANUFACTURER & MODEL No.
RCD	SUPPLY	SEE PLANS	SEE PLANS	N/A	SPRAL DUCT	YES	AL	WHITE	PRICE RODE
RR	RETURN	SEE PLANS	SEE PLANS	RECT.	CEILING	NO	AL	WHITE	PRICE 530
ER	EXHAUST	SEE PLANS	SEE PLANS	SQUARE	CEILING	NO	AL	WHITE	PRICE 530

- NOTES:
- 1. PROVIDE FRAME SUITABLE FOR SURFACE MOUNTING, CEILING OR SIDEWALL; COORDINATE MOUNTING AND FINISH REQUIREMENTS WITH ARCHITECTURAL, CEILING PLANS.
- 2. REFER TO DRAWINGS FOR NECK SIZES AND CFM UNLESS NOTED ABOVE; PROVIDE SQUARE TO ROUND TRANSITIONS WHERE REQUIRED.
- 3. AIR VELOCITY TO REGISTER/GRILLE/DIFFUSER TO BE 400 FPM OR BELOW.

Tony Fallon Architecture
501 Barn Door Gap Strafford, New Hampshire 03884-6233
603 269 3206
tonyfallon.com Licensed by New Hampshire, Maine, & Massachusetts
tony@tonyfallon.com

Sanctuary Medicinals, Inc.
Phase 2 VE
12 April 2018
234 Taylor Street
Littleton, Massachusetts

Mechanical Schedules

M0.2



SUBMITTAL DATA

for

ATC Sanctuary Littleton

Sold to

Nominal 300 Ton Air Cooled Chiller

47F to 40F with 30% Prop Glycol

Prepared for

BLW

Job Number: DIN2YS

Customer PO#:

Prepared by

HTS

6/8/2017

Table of Contents

Technical Data Sheet for 300 Ton Air Cooled Screw ...	3
AWV-A Clearance_Drawing for 300 Ton Air Cooled Scr.....	7
AWV-A Close Spacing_Drawing for 300 Ton Air Cooled.....	8
AWV-A Field Wiring Diagram, Single Point Connectio.....	11
Drawings Sheet1 for 300 Ton Air Cooled Screw Chill.....	12
Drawings Sheet2 for 300 Ton Air Cooled Screw Chill.....	13
Drawings Sheet3 for 300 Ton Air Cooled Screw Chill.....	14
Drawings Sheet4 for 300 Ton Air Cooled Screw Chill.....	15

Technical Data Sheet for 300 Ton Air Cooled Screw Chiller June 8

Job Information		Technical Data Sheet
Job Name	ATC Sanctuary Littleton	
Date	6/8/2017	
Submitted By	Derek Annese	
Software Version	07.50	
Unit Tag	300 Ton Air Cooled Screw Chiller June 8	



Unit Overview

Model Number	Capacity ton	IPLV.IP* EER Btu/W.h	Voltage	Unit Starter Type	ASHRAE 90.1	LEED EA Credit 4
AWV020A	294.0	18.10	460 / 60.0 / 3	VFD	'07, '10, '13/'16	Pass

* IPLV reflects AHRI standard rating conditions and may change with user defined conditions due to AWV product optimized configurability.

Unit

Unit Type			Platform			Unit Revision	
Air-Cooled Screw Compressor Chiller			Packaged			00	
Head Pressure			Tubing				
AC Fan Motors / VFD (First Fans / Circuit)			No Liquid Solenoid Valves & No Suction Shut-off Valves				
Display							
On Controller only							
Compressor				Economizer			
JJN				KKN			
Refrigerant Type				Refrigerant Weight			
R134a				463 lb (per unit)			
Approval							
ETL/cETL, AHRI & ASHRAE 90.1							
Evaporator							
Evaporator Modell:	EV6633A1507						
Water Volume:	224.8 gal						
Connection Hand:	Grooved / Left Hand						
Connection Size:	10.0 in						
Insulation:	Single Layer Insulation on Evaporator						
Entering Fluid Temperature	Leaving Fluid Temperature	Fluid Type	Glycol Concentration	Fluid Flow	Fluid Flow (with glycol) Min / Max	Pressure Drop	Fouling Factor
47.00 °F	40.00°F	Water & Propylene	30.0 %	1068 gpm	358.1 / 1415.5 gpm	24.8 ft H ₂ O	0.000100 °F.ft ² .h/Btu
Condenser							
Number of Fans:	20						
Coil Fins:	MicroChannel						
Guards:	Condenser Coil Wire Grilles only						
Design Ambient Air Temperature	Altitude	Fan Diameter	Nominal Fan Motor Horsepower	Minimum Design Ambient Temperature			
95.0 °F	0.000 ft	31.5 in	1.2 hp	0.0 °F			

Technical Data Sheet for 300 Ton Air Cooled Screw Chiller June 8

Unit Performance

Design			
Capacity	Input Power	Efficiency (EER)	IPLV.IP* (EER)
294.0 ton	339.4 kW	10.40 Btu/W.h	18.10 Btu/W.h

Performance Points rated at AHRI Ambient Relief

Point #	% Load	Unit					Evaporator			Condenser		
		Capacity ton	Input Power kW	Efficiency (EER) Btu/W.h	Economizer Status #1; #2	Compressor RPS #1; #2	Fluid Flow gpm	Pressure Drop ft H ₂ O	Entering Fluid Temperature °F	Leaving Fluid Temperature °F	Ambient Air Temperature °F	Altitude ft
1	100.0	294.0	339.4	10.40	On; On	86; 86	1068	24.8	47.00	40.00	95.0	0.000
2	90.0	264.6	269.8	11.80	On; On	78; 78	1068	24.8	46.30	40.00	89.0	0.000
3	80.0	235.2	212.4	13.30	On; On	68; 68	1068	24.8	45.60	40.00	83.0	0.000
4	70.0	205.8	169.7	14.60	Off; Off	62; 62	1068	24.8	44.90	40.00	77.0	0.000
5	60.0	176.4	129.4	16.40	Off; Off	50; 50	1068	24.8	44.20	40.00	71.0	0.000
6	50.0	147.0	96.30	18.30	Off; Off	41; 41	1068	24.8	43.50	40.00	65.0	0.000
7	40.0	117.6	69.30	20.40	Off; Off	33; 33	1068	24.8	42.80	40.00	59.0	0.000
8	30.0	88.20	48.10	22.00	Off; Off	26; 26	1068	24.8	42.10	40.00	55.0	0.000
9	20.0	58.80	34.10	20.70	Off; Off	18; 18	1068	24.8	41.40	40.00	55.0	0.000
10	10.0	29.40	17.10	20.60	Off; Off	18	1068	24.8	40.70	40.00	55.0	0.000

* IPLV reflects AHRI standard rating conditions and may change with user defined conditions due to AWV product optimized configurability.

Technical Data Sheet for 300 Ton Air Cooled Screw Chiller June 8

Sound Data (Internal Discharge Compressor Muffler)

Sound Pressure (at 30 feet)									
% Load	63 Hz db	125 Hz db	250 Hz db	500 Hz db	1 kHz db	2 kHz db	4 kHz db	8 kHz db	Overall dBA
100	80	77	73	71	70	64	57	50	74
90	79	76	72	72	69	62	56	49	73
80	78	75	71	72	69	59	54	47	72
70	78	75	72	69	67	59	54	47	71
60	77	74	70	68	65	57	52	45	69
50	76	73	69	66	63	55	50	44	68
40	75	72	67	65	61	53	48	42	66
30	75	70	65	63	59	51	45	39	64
20	74	69	63	61	57	48	43	37	62
10	71	66	60	58	54	45	40	34	59

Sound Power									
% Load	63 Hz db	125 Hz db	250 Hz db	500 Hz db	1 kHz db	2 kHz db	4 kHz db	8 kHz db	Overall dBA
100	107	104	100	98	97	91	84	77	101
90	106	103	99	99	96	89	83	76	101
80	105	102	98	99	96	86	81	74	99
70	105	102	99	96	94	86	81	74	98
60	104	101	97	95	92	84	79	72	96
50	103	100	96	93	90	82	77	71	95
40	102	99	94	92	88	80	75	69	93
30	102	97	92	90	86	78	72	66	91
20	101	96	90	88	84	75	70	64	89
10	98	93	87	85	81	72	67	61	86

One-third Octave Band Sound Power																								
% Load	50 Hz	63 Hz	80 Hz	100 Hz	125 Hz	160 Hz	200 Hz	250 Hz	315 Hz	400 Hz	500 Hz	630 Hz	800 Hz	1 kHz	1.25 kHz	1.6 kHz	2 kHz	2.5 kHz	3.15 kHz	4 kHz	5 kHz	6.3 kHz	8 kHz	10 kHz
100	103	102	100	99	99	100	95	96	93	95	95	90	90	94	91	89	85	83	81	79	78	76	68	62
90	103	102	99	98	98	99	95	96	93	95	96	89	91	92	91	86	84	82	79	78	77	75	67	61
80	101	100	98	97	97	98	93	94	91	98	92	88	92	90	90	84	81	80	77	76	75	73	65	59
70	101	100	98	97	97	98	94	95	93	94	92	88	89	90	90	83	81	79	77	75	75	73	65	60
60	100	99	97	96	96	96	92	93	93	91	90	88	87	87	87	81	79	77	75	73	73	71	64	58
50	99	99	97	95	95	95	92	93	89	90	89	85	86	86	85	79	77	76	73	72	71	70	62	56
40	99	98	96	94	95	93	89	90	87	88	87	84	84	84	83	77	75	74	71	70	69	68	60	55
30	98	97	95	93	94	90	87	88	86	86	86	82	82	81	80	74	73	71	69	67	67	65	58	52
20	97	96	95	92	93	88	85	86	84	84	84	80	81	79	78	72	70	68	66	65	64	63	55	50
10	94	93	92	89	90	85	82	83	81	81	81	77	78	76	75	69	67	65	63	62	61	60	52	47

Octave band is non 'A' weighted and overall readings are 'A' weighted. Sound data rated in accordance with AHRI Standard-370.

Physical

Unit				
Length*	Height	Width*	Shipping Weight*	Operating Weight*
410 in	100 in	88 in	18692 lb	20612 lb

* Shipping and operating weights do not include the weights of any Options or Accessories. Contact Chiller Applications for additional information.

Technical Data Sheet for 300 Ton Air Cooled Screw Chiller June 8

Electrical

Unit Electrical Data				
Voltage	Starter Type	Fan Motor Quantity	LRA Fan Motor (each)	FLA Fan Motors (each)
460 / 60.0 / 3	VFD	20	10A	3.3A
Power Connection Type:	Single Point Disconnect Switch with Circuit Protection			
Short Circuit Current Rating:	5 kA			
Drive Type(#1;#2):	CIMR-AU4A0250;CIMR-AU4A0250			
Phase Voltage:	Phase & Under/Over Voltage Protection with LED			

Single Point Power Connection	
MCA:	541 A
Fuse Size (recommended):	600 A
Fuse Size (maximum):	700 A
Connector Wire Range:	(2) 3/0-500MCM

Compressor Electrical Data		
Compressor Type	Compressor Quantity	Starter Type
Screw	2	VFD
	Compressor #	
	1	2
RLA:	207 A	207 A
Inrush Current:	207 A	207 A

Note: Power wiring connections to the chiller may be done with either copper or aluminum wiring. Wire should be sized per NEC and/or local codes. Wire sizing and wire count must fit in the power connection lug sizing listed in latest installation manual. Please contact your local sales office for more information.

Options

Control	
Communication:	BACnet IP
Electrical	
Unit Options:	115V Convenience Outlet
Water Flow Indicator:	Thermal Dispersion Type

Warranty

Unit Startup	Domestic
Standard Warranty:	1st Year Entire Unit Parts & Labor
Extended Compressor Warranty:	Compressor Only; extended 4 years parts & labor

AHRI Certification



Certified in accordance with the AHRI Air-Cooled Water-Chilling Packages Using Vapor Compression Cycle Certification Program, which is based on AHRI Standard 550/590 (I-P) and AHRI Standard 551/591 (SI). Unit containing freeze protection fluids in the condenser or in the evaporator with a leaving chilled fluid temperature above 32°F [0°C] is certified when rated per the Standard with water. Certified units may be found in the AHRI Directory at www.ahridirectory.org.

AWV-A Service Clearance

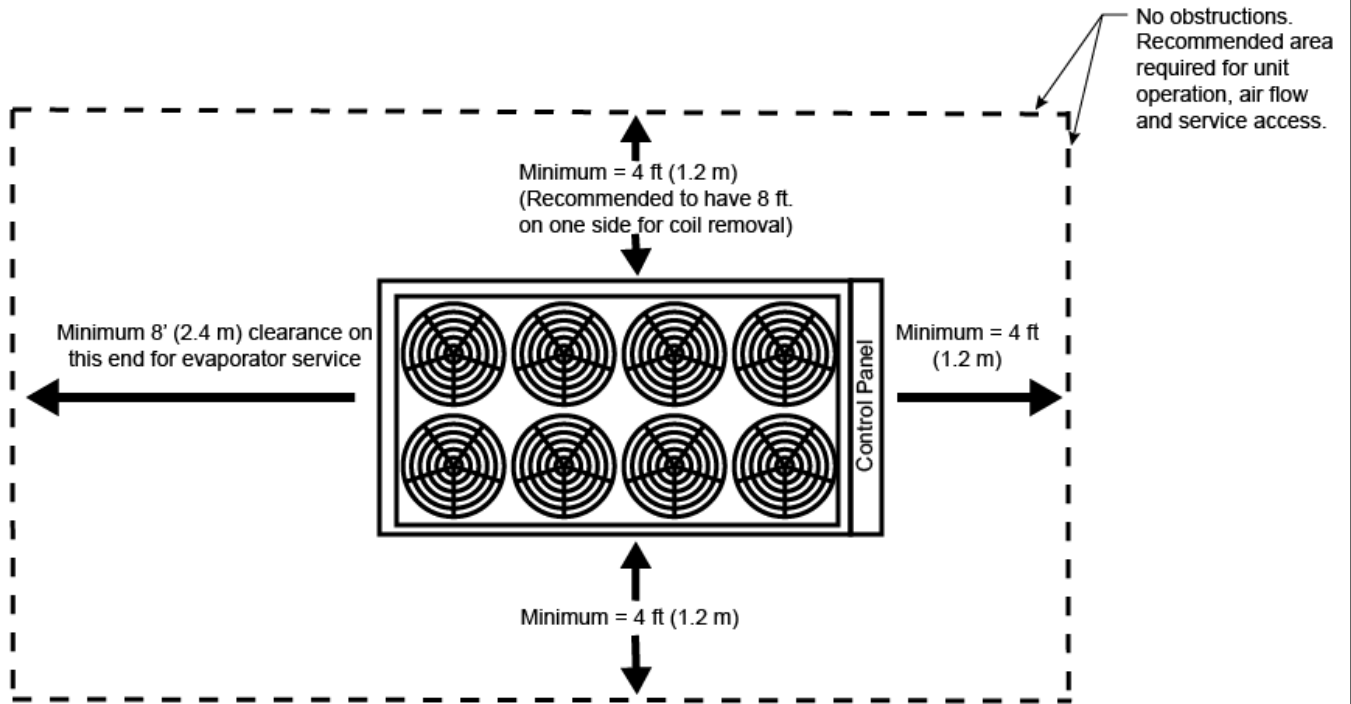

Product Drawing	Unit Tag: 300 Ton Air Cooled Screw			 13600 Industrial Park Blvd. Minneapolis, MN 55441 www.DaikinApplied.com Software Version: 07.50
Product: Air-Cooled Screw Chiller	Project Name: ATC Sanctuary Littleton			
Model: AWV-A	Sales Office: HTS New England (Boston)			Scale: NTS
Sales Engineer: Derek Anneser	June 08, 2017	Ver/Rev:	Sheet 1 of 1	Tolerance: +/-1.0" Dwg Units: in [mm]
No change to this drawing may be made unless approved in writing by Daikin Applied. Purchaser must determine that the equipment is fit and sufficient for the job specifications.				

AWV Close Spacing Performance

Case 1: Building or Wall on One Side of Unit

For all models, maintain a 4 feet minimum from a wall of any height; however, performance may be affected at this distance due to air recirculation and elevated condenser pressure.

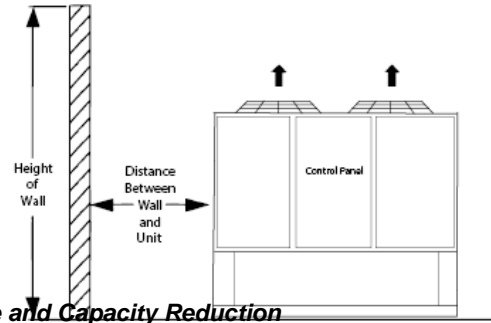

Case 1- Full Load Power Increase and Capacity Reduction

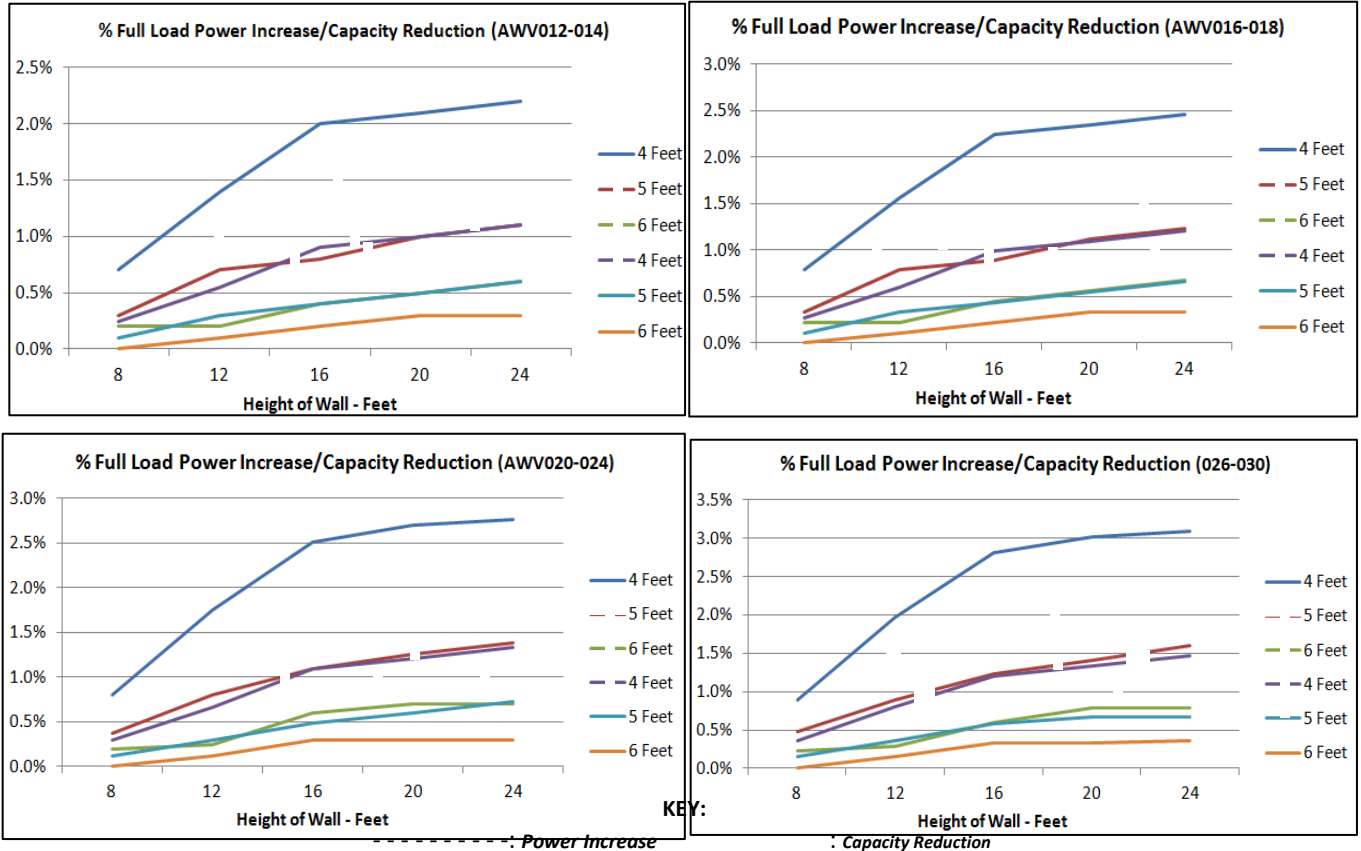

Case 2: Two Units, Side-by-Side

For all models, there must be a minimum of 6 feet between two units placed side-by-side; however, performance may be affected at this distance due to air recirculation and elevated condenser pressure.

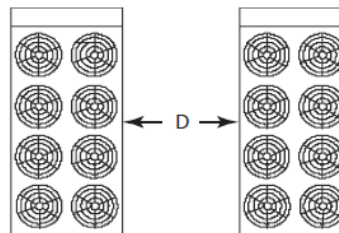

Product Drawing		Unit Tag: 300 Ton Air Cooled Screw			 13600 Industrial Park Blvd. Minneapolis, MN 55441 www.DaikinApplied.com Software Version: 07.50		
Product: Air-Cooled Screw Chiller		Project Name: ATC Sanctuary Littleton					
Model: AWV-A		Sales Office: HTS New England (Boston)			Scale: NTS		
Sales Engineer: Derek Anneser		June 08, 2017	Ver/Rev:	Sheet 1 of 1	Tolerance: +/-1.0" Dwg Units: in [mm]		
No change to this drawing may be made unless approved in writing by Daikin Applied. Purchaser must determine that the equipment is fit and sufficient for the job specifications.							

AWV-A Close Spacing_Drawing for 300 Ton Air Cooled Screw Chiller June 8

Case 2 - Full Load Capacity Reduction and Power Increase

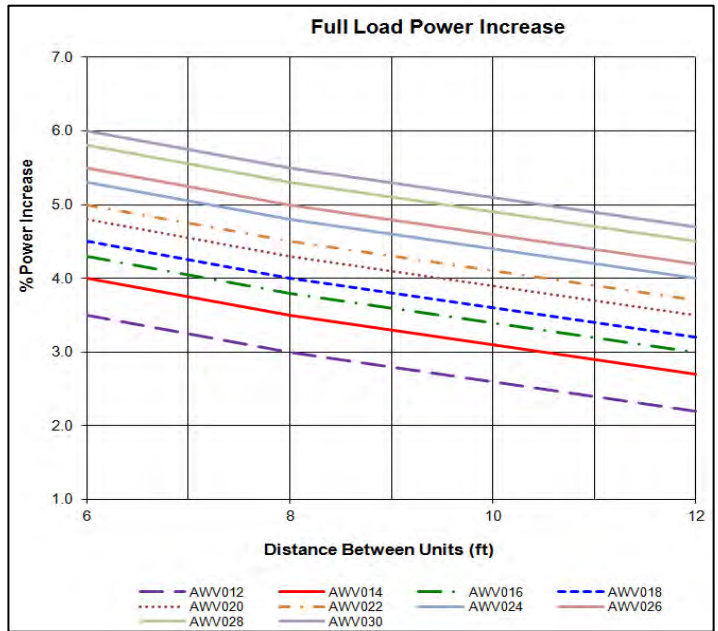
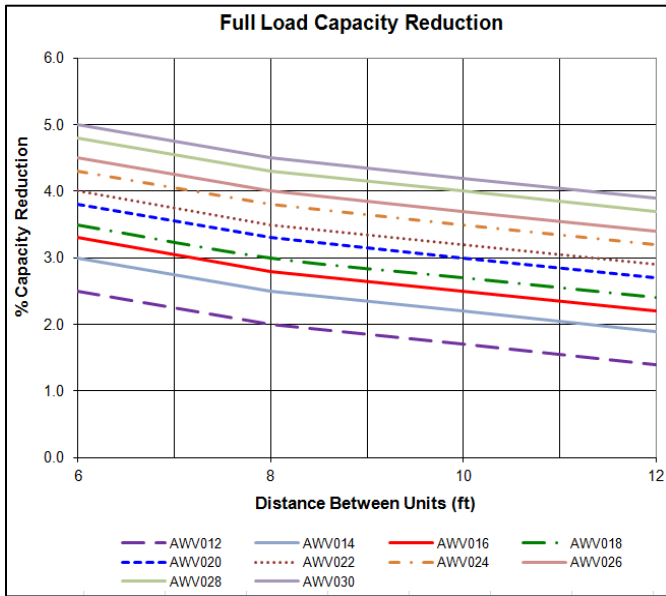

Case 3: Three or More Units, Side-by-Side

For all models, there must be a minimum of 8 feet between any units placed side-by-side; however, performance may be affected at this distance.

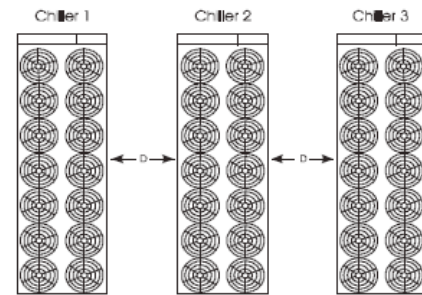

Case 3 - Full Load Capacity Reduction and Power Increase

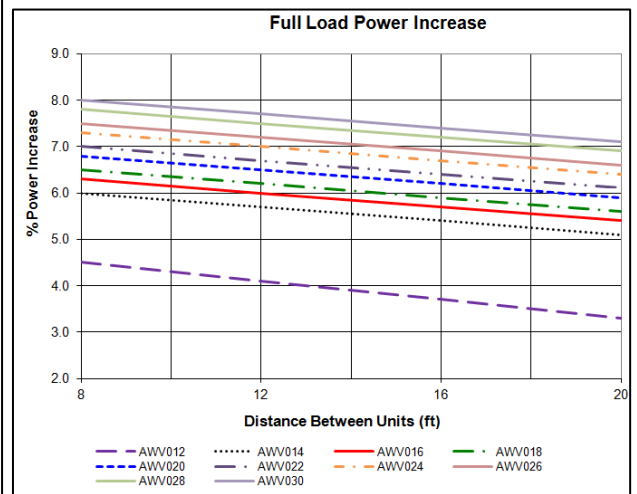
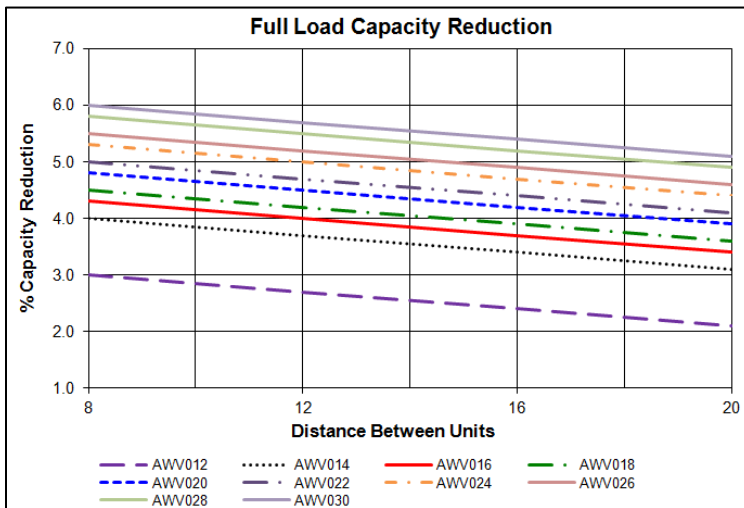

Case 4: Open Screening Walls

Decorative screening walls are often used to help conceal a unit either on grade or on a rooftop. When possible, design these walls such that the combination of their open area and distance from the unit do not require performance adjustment. If the wall opening percentage is less than recommended for the distance to the unit, it should be considered as a solid wall. It is assumed that the wall height is equal to or less than the unit height when mounted on its base support. If the wall height is greater than the unit height, see Case 5: Pit Installation. The distance from the sides of the unit to the side walls must be sufficient for service, such as opening control panel doors. For uneven wall spacing, the distance from the unit to each wall can be averaged providing no distance is less than 4 feet. Values are based on walls on all four-sides.

AWV-A Close Spacing_Drawing for 300 Ton Air Cooled Screw Chiller June 8

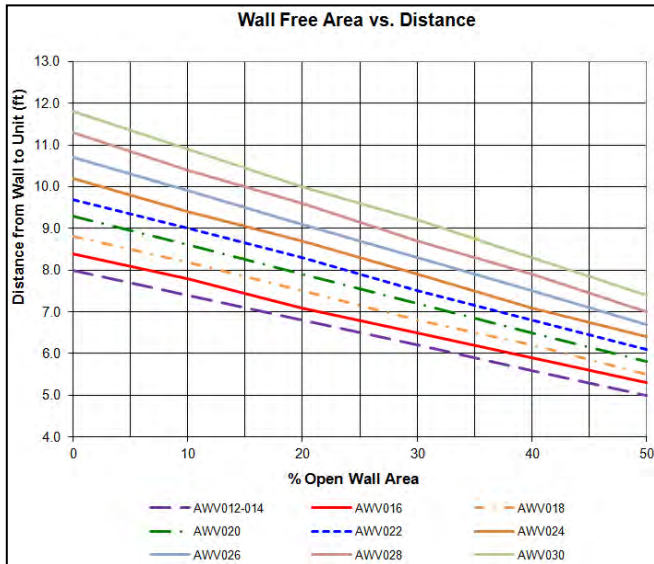

Case 4 - Allowable Wall Open Area

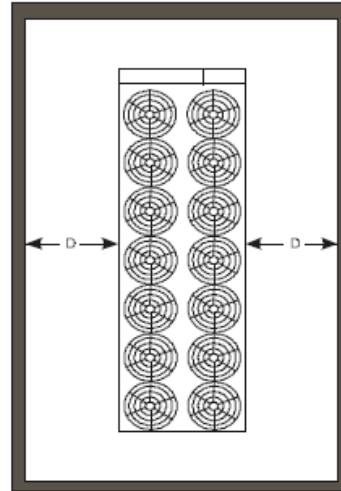

KEY:

Capacity Reduction

Power Increase

Case 5: Pit Installation

Pit installations can cause operating problems resulting from air recirculation and restriction and require care that sufficient air clearance is provided, safety requirements are met and service access is provided. A solid wall surrounding a unit is substantially a pit and this data should be used.

Steel grating is sometimes used to cover a pit to prevent accidental falls or trips into the pit. The grating material and installation design must be strong enough to prevent such accidents, yet provide abundant open area to avoid recirculation problems. Have any pit installation reviewed by the Daikin Applied sales representative prior to installation to ensure it has sufficient air-flow characteristics and approved by the installation design engineer to avoid risk of accident.

Case 5 - Full Load Capacity Reduction and Power Increase

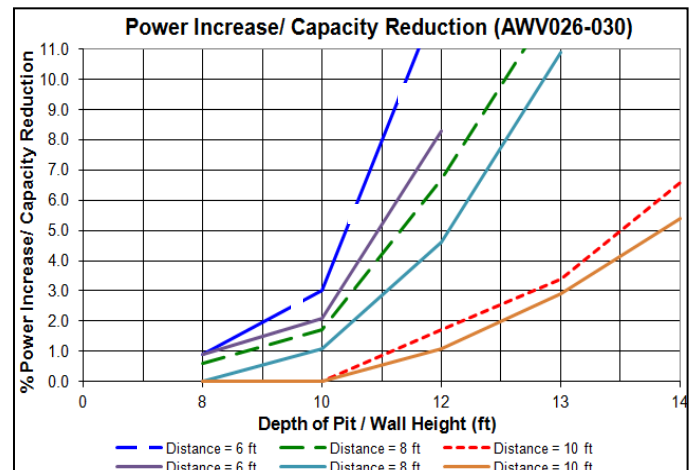
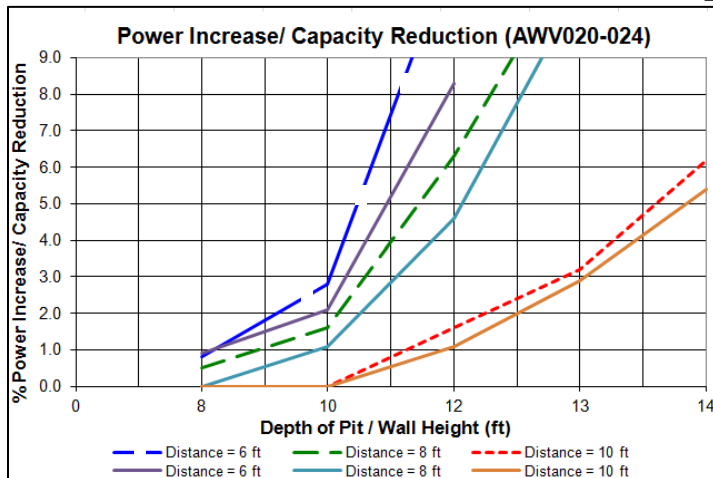
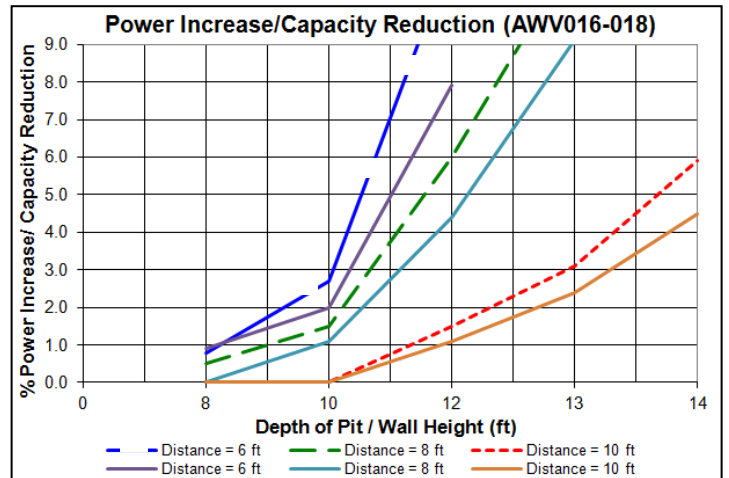
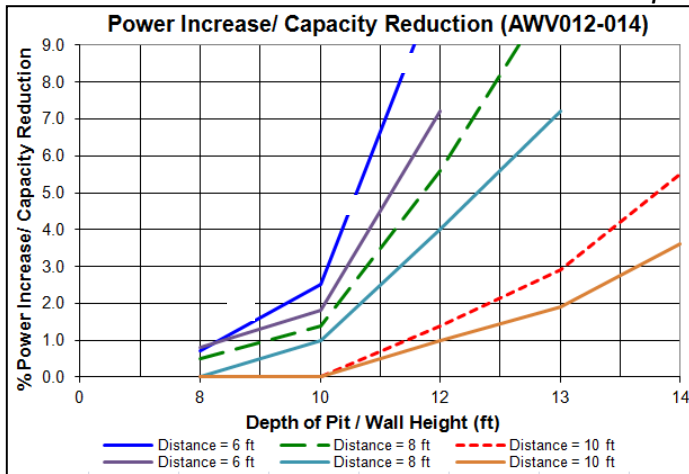

AWV Single-Point Connection Field Wiring Diagram

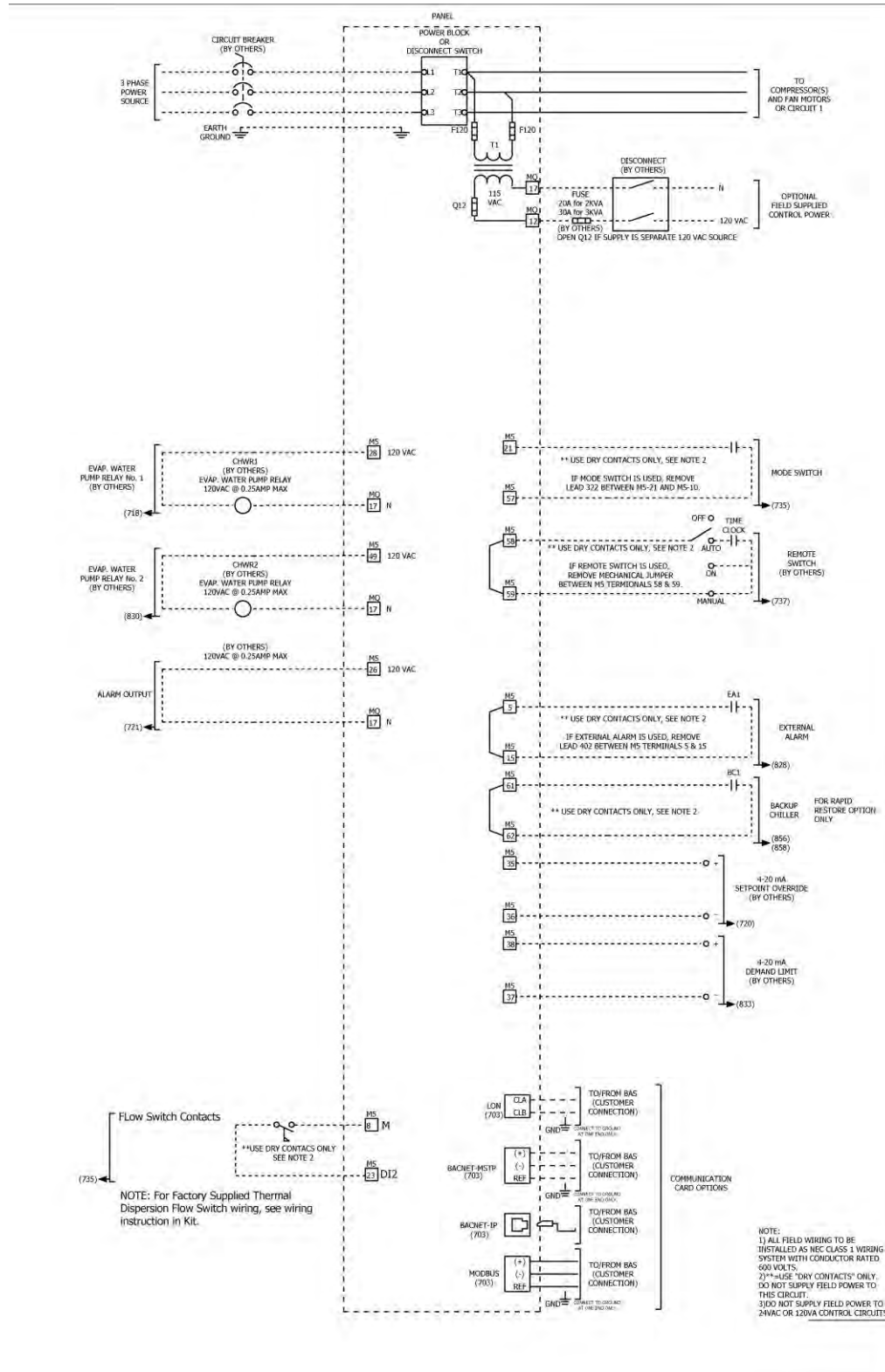

Field Wiring Diagram		Unit Tag: 300 Ton Air Cooled Screw		 13600 Industrial Park Blvd. Minneapolis, MN 55441 www.DaikinApplied.com Software Version: 07.50		
Product: Air-Cooled Screw		Project Name: ATC Sanctuary Littleton				
Model: AWV Single-Point		Sales Office: HTS New England (Boston)		Scale: N/A	Tolerance: N/A	Dwg Units: N/A
Sales Engineer: Derek Anneser		June 08, 2017	Ver/Rev:	Sheet 1 of 1		
No change to this drawing may be made unless approved in writing by Daikin Applied. Purchaser must determine that the equipment is fit and sufficient for the job specifications.						

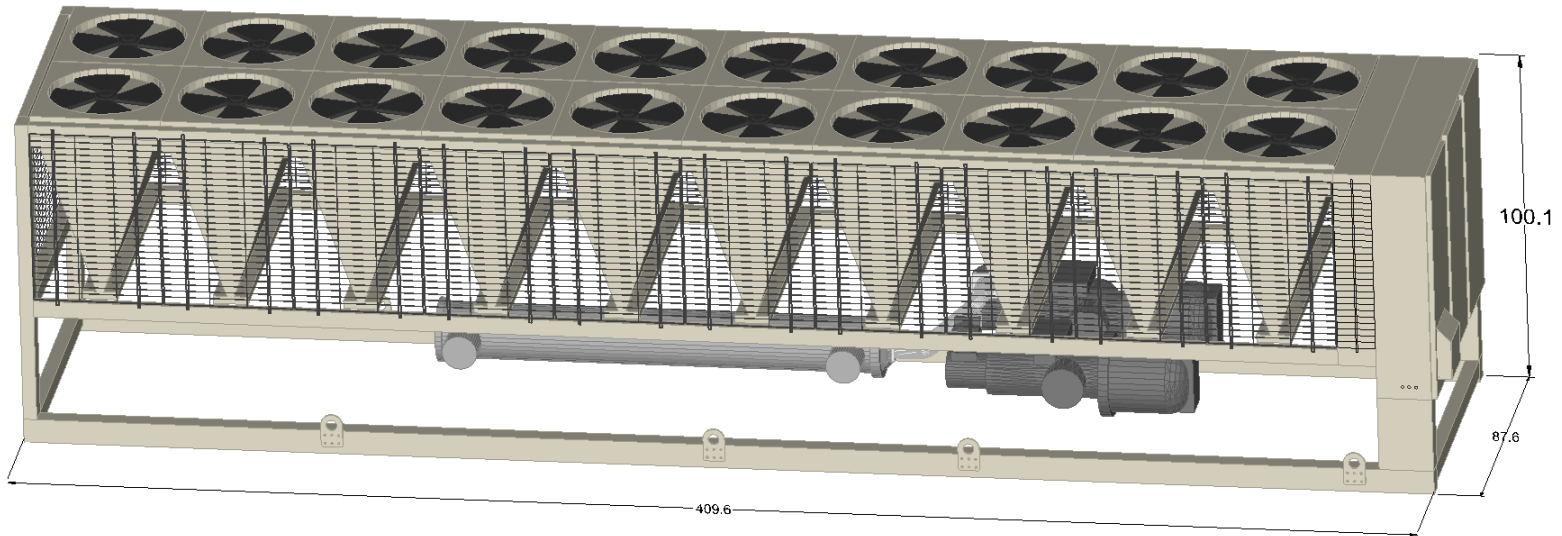

NOTE: A water strainer must be installed at the inlet of the evaporator to protect it from damage. Please refer to the IOM for additional details.

Product Drawing	Unit Tag: 300 Ton Air Cooled Screw			Sales Office: HTS New England (Boston)			 13600 Industrial Park Blvd. Minneapolis, MN 55441 www.DaikinApplied.com Software Version: 07.50
	Project Name: ATC Sanctuary Littleton			Sales Engineer:			
	Model: AWW020A	June 08, 2017	Ver/Rev:	Sheet: 1 of 1	Scale: NTS	Tolerance: +/- 0.25"	

No change to this drawing may be made unless approved in writing by Daikin Applied. Purchaser must determine that the equipment is fit and sufficient for the job specifications.



September 8, 2020

Cannabis Control Commission
Union Station
2 Washington Square
Worcester, MA 01604

RE: **Sanctuary Medicinals**
234 Taylor Street
Littleton, MA

BLW Engineers, Inc. (BLW) is pleased to provide the commission with our approach for energy compliance for the Sanctuary Medicinals Cultivation Facility.

1. Sanctuary Medicinals has incorporated several energy-use reduction opportunities including the following
 - A. High Efficiency Chillers that exceed minimum requirements of 2015 IECC
 - B. High Efficiency Boilers that exceed minimum requirements of 2015 IECC
 - C. Energy recovery air handling units. The air handling units save over 30% of cooling costs and over 50% of heating costs.
 - D. Reduction of horticultural lighting power density (HLPD) below 36 watts per square foot.
2. Renewable energy opportunities were explored for Sanctuary Medicinals. However, we are unable to employ any renewable energy due to site restrictions.
3. Many strategies are being used to reduce electric demand including the following
 - A. Staggered lighting schedules in flower rooms
 - B. Dimming schedules
4. Sanctuary Medicinals has an engagement in the Mass Save energy efficiency program with National Grid and has received incentives for the .
5. Attached to this letter you will find the following
 - A. Building Envelope
 - i. The building is an existing building, so a building envelope comcheck could not be completed. However, the insulated metal panels used in the facility provide an R20 insulation value, which exceeds current energy codes.
 - B. HLPD Compliance information
 - i. Stamped HLPD Memo
 - ii. Floor plan showing lighting and horticultural lighting square footage (HLSF)
 - iii. Calculations spreadsheet
 - iv. Lighting data sheets



-
- C. HVAC & dehumidification compliance information
 - i. Stamped HVAC Memo
 - ii. Equipment list
 - iii. Capacities
 - iv. Data sheets.
 - D. An application to the Mass Save program for energy efficient measures
 - E. Eye Safety Plan

If you have any questions or need additional information, please feel free to contact our office.

Very truly yours,

Erik M Gath

Erik M. Gath, PE, CBCP
Associate Principal
BLW Engineers, Inc.

BLW ENGINEERS, INC.

MEMORANDUM

DATE: September 8, 2020

TO: Cannabis Control Commission

FROM: Erik M. Gath, PE - BLW Engineers

PROJECT: Sanctuary Medicinals
234 Taylor Street, Littleton, MA

SUBJECT: Horticulture Lighting Power Density (HLPD)

COPIES TO: Sanctuary Medicinals

Per the lighting plans and calculations attached.

1. There is a total of 26,754 square feet of horticultural lighting square footage.
2. There is a total of 931,393 watts of horticultural lighting.

This results in an HLPD of

34.8 watts/sf.





ULTRA-SLIM DESIGN FOR VEGETATION & FLOWERING

FEATURES & SPECIFICATIONS

General Description

The NeoPAR is ideal for vertical rack and low mounting height applications. The NeoPAR 7 is designed to deliver high levels of photosynthetic photon flux (PPF) to produce quality flowering. The NeoPAR series provides the thinnest profile available with an onboard power pack. This slim design delivers unsurpassed light uniformity for damp locations. The NeoPAR series arrives fully assembled to limit labor cost with simple installation.

Mechanical Construction

The fully assembled product is a slim design compatible for different types of vertical farming. The overall size of the product is 45"x42"x3". The 7 LED bars mount to a structurally safe back plate. The LED bars are 3/8" thick x 2.65" wide x 45" long. The back plate spans across the equally spaced LED bars which houses the LED drivers, wiring and any controls systems that may be used as add on accessories. The product is easy to install using standard mechanical fastening systems.

Power Consumption

The NeoPAR is offered in two power levels to meet a variety of needs in grow operations. Whether the priority is high output for crops requiring a ton of light or maximize efficiency for energy restriction or rebates, there is a solution. Power ranges from 70-90 watts a bar depending on configuration.

Testing & Compliance

- RoHS compliant
- ETL listing for wet locations
- IP 67 Driver
- 5-year warranty
- L70: 50,000



SPECTRUM

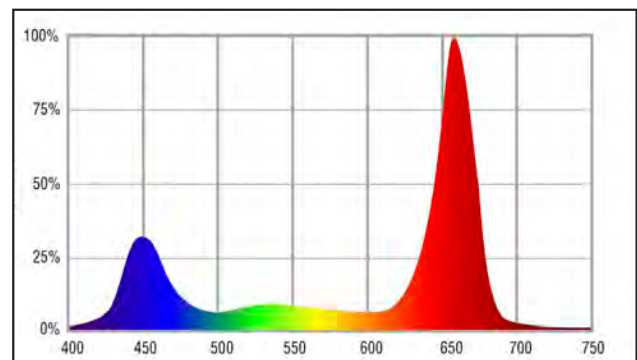

F3 - This spectrum is known as the full cycle spectrum developed specifically to foster quality growth at each stage. It produces fast germination and high quality vegetative and flowering plants.

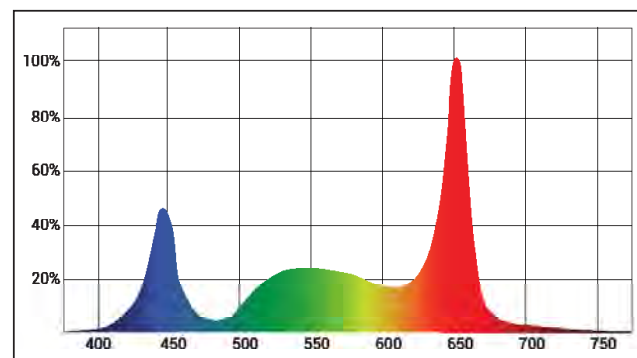

X6 - This full spectrum maximizes red and blue nm wavelengths to allow for optimal chlorophyll A and B absorption with a balance of green wavelengths to allow much deeper canopy penetration.

Manufactured in Austin, TX

NeoPAR 7

PART NUMBER ORDERING GUIDE

Series	# of bars	Output	Beam Angle	Lens/IP	Spectrum	Voltage	Dimming	Color	Cord	Plug*
DH Damp	7	S Standard	12 120° beam	NL No Lens	X6	U 120-277	D 0-10	WH	10 (ft)	Blank None
DHW Wet		E Efficiency								P120
										P240
										P277

*Notes: Additional charges apply for including a 3-prong plug.

GENERAL ATTRIBUTES

Operating Frequency	50/60Hz
Operating Temperature	4°F to 104°F (-20°C to 40°C)
Dimensions	45" x 42" x 3"
Estimated Weight	32.5 lbs
Power Factor	>0.90
Warranty	5 years

LINE DRAWINGS & DIMENSIONS

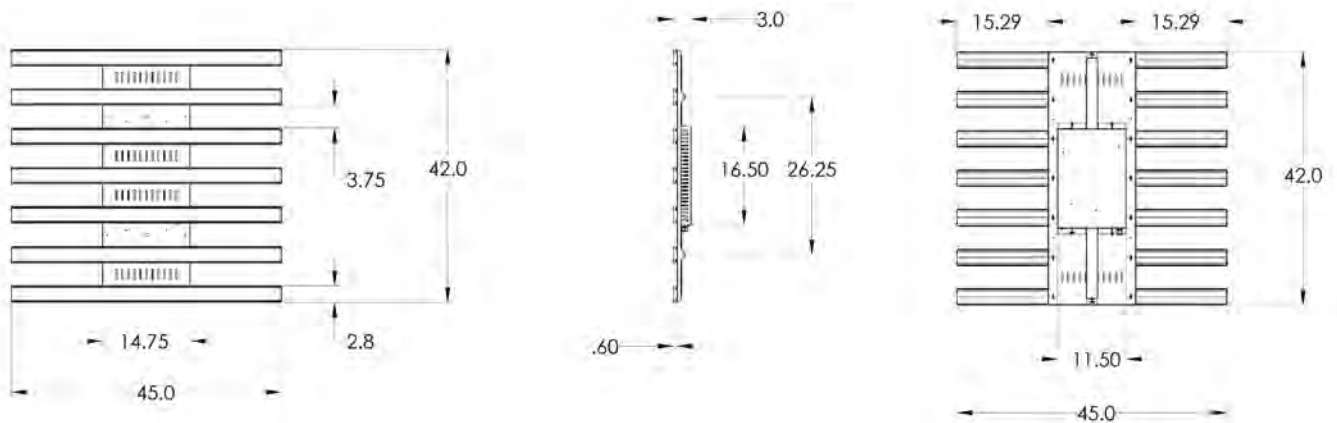
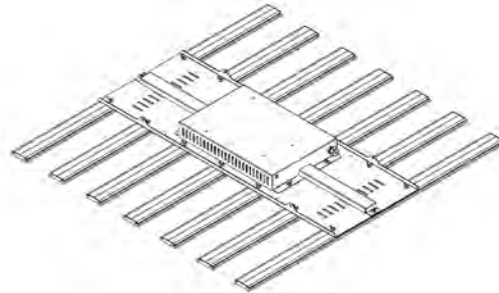
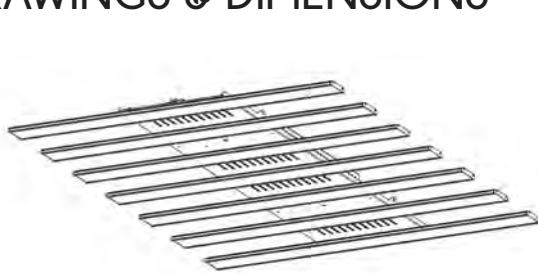

NeoPAR 7

STANDARD SPECIFICATION

X6 SPECTRUM					
Input Voltage	120 VAC	240 VAC	277 VAC	347 VAC	480 VAC
PPF	1275				
Efficiency	1.93 $\mu\text{mol}/\text{J}$	2.04 $\mu\text{mol}/\text{J}$	2.05 $\mu\text{mol}/\text{J}$	1.99 $\mu\text{mol}/\text{J}$	2.00 $\mu\text{mol}/\text{J}$
Power Consumption	661 W	626 W	622 W	642 W	636 W
Current	5.5 A	2.66 A	2.33 A	1.97 A	1.36 A
BTU/hr	2254.0	2134.7	2121.0	2189.2	2168.8

F3 SPECTRUM					
Input Voltage	120 VAC	240 VAC	277 VAC	347 VAC	480 VAC
PPF	1450				
Efficiency	2.17 $\mu\text{mol}/\text{J}$	2.29 $\mu\text{mol}/\text{J}$	2.31 $\mu\text{mol}/\text{J}$	2.22 $\mu\text{mol}/\text{J}$	2.26 $\mu\text{mol}/\text{J}$
Power Consumption	667 W	632 W	628 W	652 W	643 W
Current	5.54 A	2.67 A	2.35 A	1.90 A	1.38 A
BTU/hr	2274.5	2155.1	2141.5	2223.3	2192.6

EFFICIENCY SPECIFICATION

X6 SPECTRUM					
Input Voltage	120 VAC	240 VAC	277 VAC	347 VAC	480 VAC
PPF	1200				
Efficiency	1.95 $\mu\text{mol}/\text{J}$	2.05 $\mu\text{mol}/\text{J}$	2.07 $\mu\text{mol}/\text{J}$	2.11 $\mu\text{mol}/\text{J}$	2.14 $\mu\text{mol}/\text{J}$
Power Consumption	616 W	585 W	581 W	568 W	562 W
Current	5.10 A	2.49 A	2.41 A	1.65 A	1.21 A
BTU/hr	2100.6	1994.9	1981.2	1936.9	1916.4

F3 SPECTRUM					
Input Voltage	120 VAC	240 VAC	277 VAC	347 VAC	480 VAC
PPF	1350				
Efficiency	2.24 $\mu\text{mol}/\text{J}$	2.36 $\mu\text{mol}/\text{J}$	2.37 $\mu\text{mol}/\text{J}$	2.29 $\mu\text{mol}/\text{J}$	2.31 $\mu\text{mol}/\text{J}$
Power Consumption	603 W	573 W	569 W	589 W	584 W
Current	5.00 A	2.44 A	2.15 A	1.72 A	1.26 A
BTU/hr	2056.2	1953.9	1940.3	2008.5	1991.4

ILUMINAR™

CMH DE 630W FIXTURE

277V

LUMINAR 630W DE CMH Fixture is designed for commercial applications. This is the ideal fixture for all your cultivating applications and is coming out on top with the most effective dimmable control and reflectivity on the reflector. Case design dissipates heat quickly making it supremely cool running without the need for fans.



Cleaner Light for Max Yields



Less Heat Reduced Cooling Costs

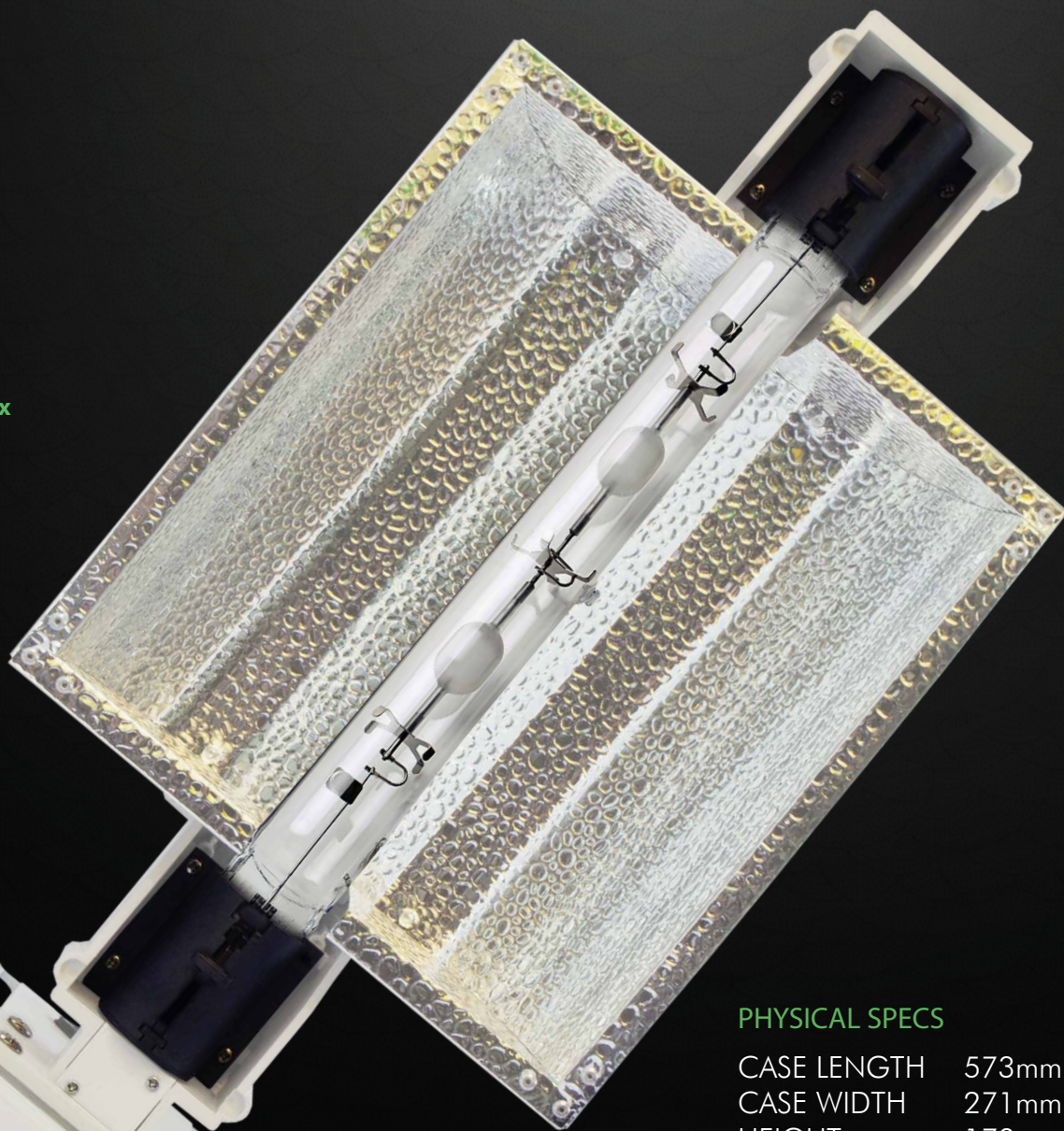

PHYSICAL SPECS

CASE LENGTH	573mm / 22.56"
CASE WIDTH	271mm / 10.65"
HEIGHT	178mm / 7.01"
WEIGHT	6kg / 13.23 lb



Dimming
ILUMINAR



A Division of
Luminous Planet Ltd.

877.540.5588 x100

sales@iluminarlighting.com

www.iluminarlighting.com

TECHNICAL INFO 630W DE CMH

INPUT VOLTS (+/- 10%)	277V
INPUT CURRENT	2.27A
INPUT POWER	675W
VOLTAGE RANGE	249-290V
THD	<15%
MAIN FREQUENCY	50/60 Hz



Energy Efficient

- ◀ 630 W Full Spectrum
- ◀ Uniform Light Distribution
- ◀ Low Frequency
- ◀ Ignition Failure Protection
- ◀ Square Wave Technology



Random Start Technology



Dimmable

ADDITIONAL TECHNICAL INFO 630W DE CMH

MIN POWER FACTOR	.95
CREST FACTOR	<1.7
INPUT CONNECTION	IP68 Wieland Plug
OPERATION FREQUENCY	140-220Hz
DIMMING GEAR	315 / 475 / 630 / 675 / EXT
RELATIVE HUMIDITY	25-70% (Non-condensing)
OPERATION TEMP.	-20 - 40°C / -4-104°F
RECOMMENDED LAMP	630W DE



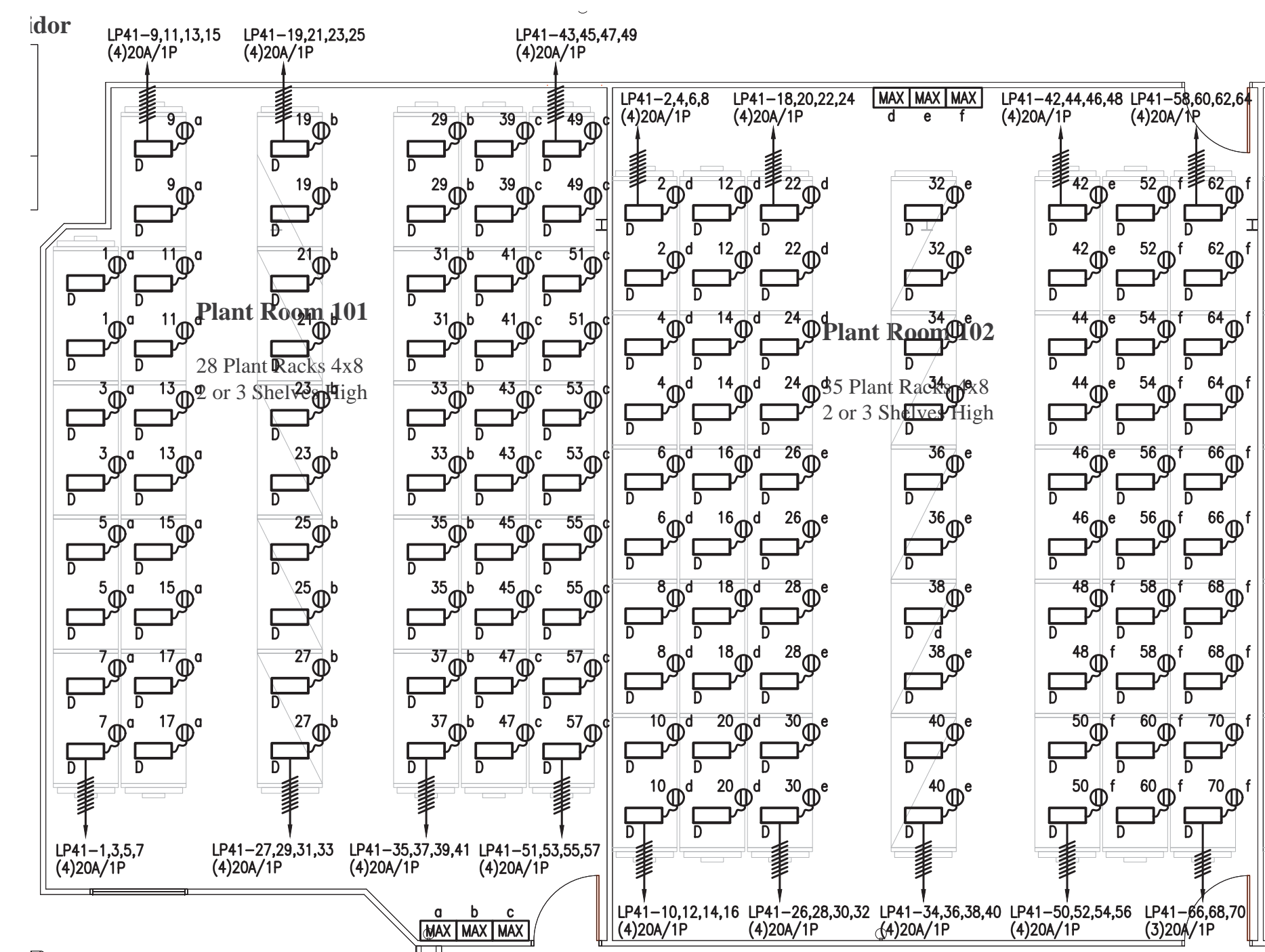

1 ELECTRICAL - Grow Rooms 101 & 102
SCALE: 1/8" = 1'-0" TIERS 1,2,3

- NOTES:**
- ELECTRICAL CONTRACTOR SHALL PROVIDE ALL CONDUIT, CONDUCTORS AND RECEPTABLES ASSOCIATED WITH TYPE D FIXTURES AT RACK SECTIONS. RACK SECTION SHALL INCLUDE (6) TYPE D FIXTURES; (2) FIXTURES PER TIER AND (3) TIERS. BRANCH CIRCUIT AND MAXI CONTROLLER ZONE INDICATED SHALL BE FOR ENTIRE RACK SECTION (3 TIERS). E.C. SHALL COORDINATE EXACT MOUNTING LOCATION OF RECEPTABLES WITH OWNER PRIOR TO INSTALLATION.
 - ELECTRICAL CONTRACTOR SHALL REFER TO GROW LIGHT RECEPTACLE MOUNTING DETAIL ON THIS SHEET FOR MOUNTING DETAILS. E.C. SHALL COORDINATE EXACT MOUNTING LOCATION WITH OWNER PRIOR TO INSTALLATION.
 - ELECTRICAL CONTRACTOR SHALL REFER TO DETAIL No. 11 ON DRAWING E0.8 FOR WIRING DETAILS ON MAXI CONTROLLER AND GROW LIGHTS. GROW LIGHTS AND MAXI CONTROLLER SHALL BE INTERCONNECTED VIA CAT6 CABLE FOR ZONE CONTROL.
 - ELECTRICAL CONTRACTOR SHALL INSTALL OWNER PROVIDED TYPE D FIXTURES AS INDICATED.

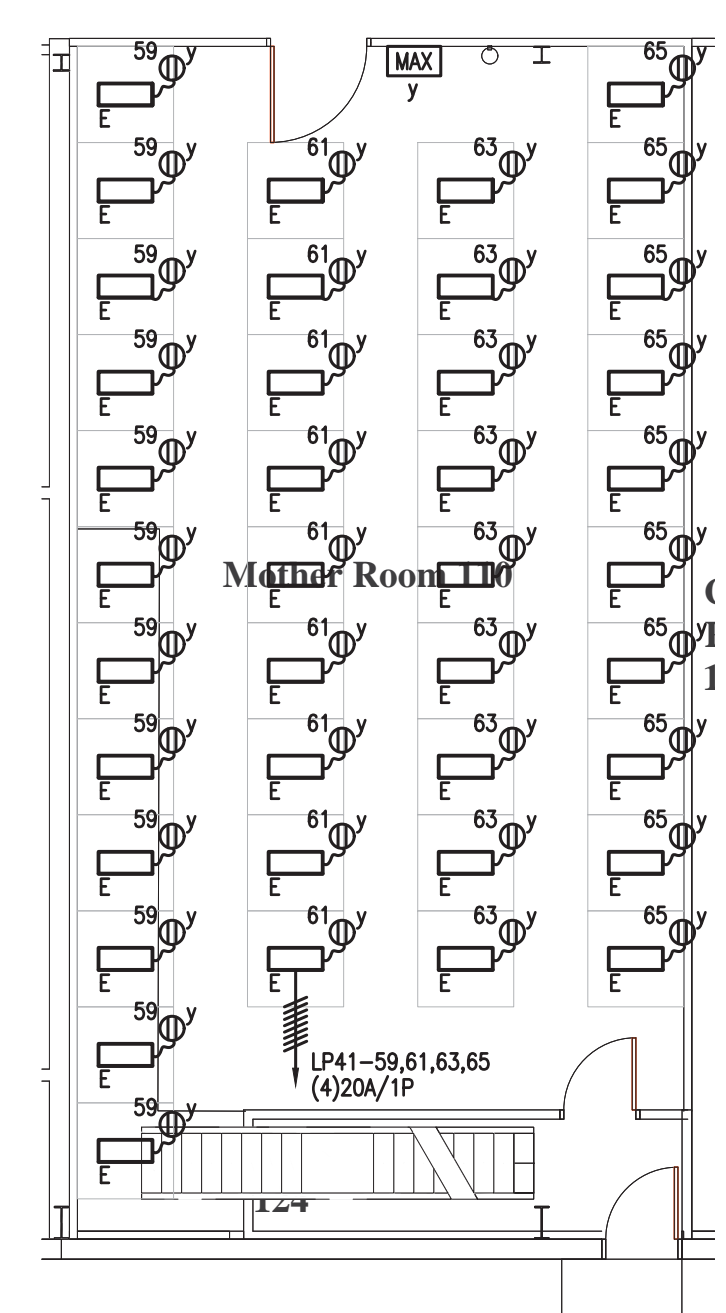

2 ELECTRICAL - Mother Room 110
SCALE: 1/8" = 1'-0" TIER 1

- NOTES:**
- ELECTRICAL CONTRACTOR SHALL PROVIDE ALL CONDUIT, CONDUCTORS AND RECEPTABLES ASSOCIATED WITH TYPE E FIXTURES AT RACK SECTIONS. RACK SECTION SHALL INCLUDE (2) TYPE E FIXTURES; (1) FIXTURE PER TIER AND (2) TIERS. BRANCH CIRCUIT AND MAXI CONTROLLER ZONE INDICATED SHALL BE FOR TIER 2 ONLY. E.C. SHALL COORDINATE EXACT MOUNTING LOCATION OF RECEPTABLES WITH OWNER PRIOR TO INSTALLATION (TYPICAL FOR MOTHER ROOM 110).
 - ELECTRICAL CONTRACTOR SHALL REFER TO GROW LIGHT RECEPTACLE MOUNTING DETAIL ON THIS SHEET FOR MOUNTING DETAILS. E.C. SHALL COORDINATE EXACT MOUNTING LOCATION WITH OWNER PRIOR TO INSTALLATION.
 - ELECTRICAL CONTRACTOR SHALL REFER TO DETAIL No. 11 ON DRAWING E0.8 FOR WIRING DETAILS ON MAXI CONTROLLER AND GROW LIGHTS. GROW LIGHTS AND MAXI CONTROLLER SHALL BE INTERCONNECTED VIA CAT6 CABLE FOR ZONE CONTROL.
 - ELECTRICAL CONTRACTOR SHALL INSTALL OWNER PROVIDED TYPE E FIXTURES AS INDICATED.

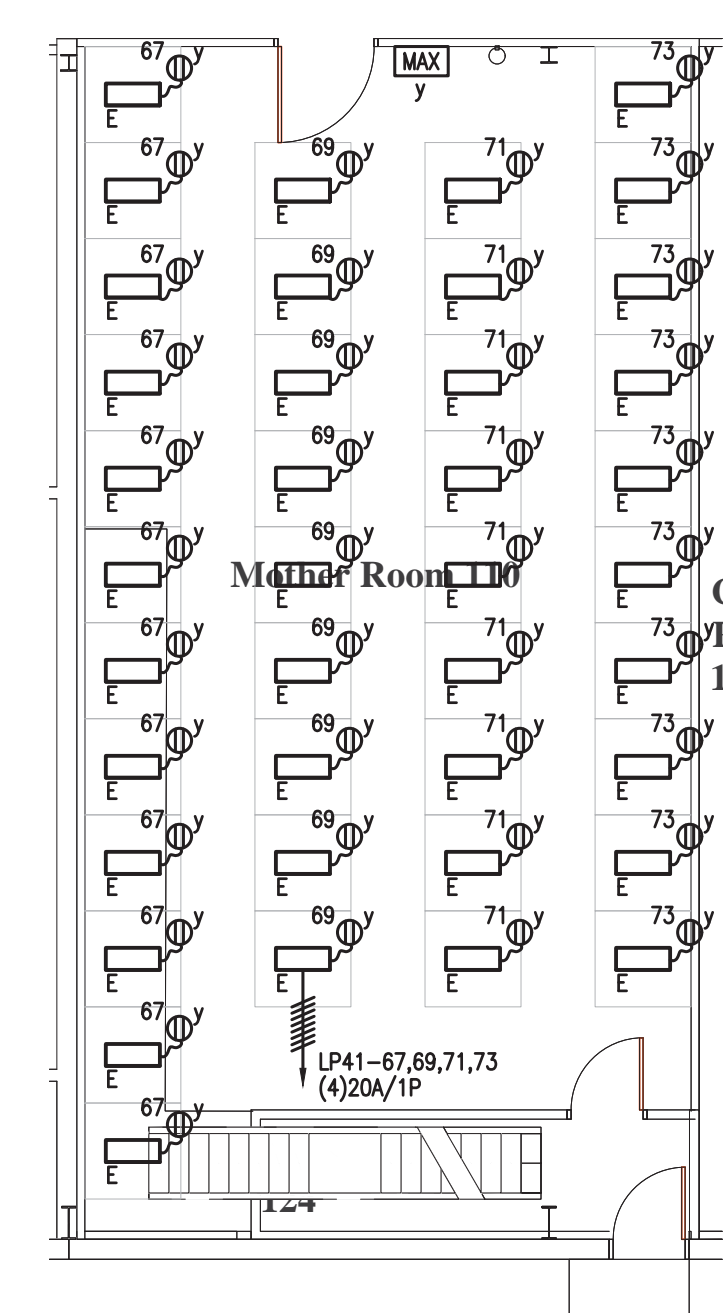

3 ELECTRICAL - Mother Room 110
SCALE: 1/8" = 1'-0" TIER 2

- NOTES:**
- ELECTRICAL CONTRACTOR SHALL PROVIDE ALL CONDUIT, CONDUCTORS AND RECEPTABLES ASSOCIATED WITH TYPE E FIXTURES AT RACK SECTIONS. RACK SECTION SHALL INCLUDE (2) TYPE E FIXTURES; (1) FIXTURE PER TIER AND (2) TIERS. BRANCH CIRCUIT AND MAXI CONTROLLER ZONE INDICATED SHALL BE FOR TIER 2 ONLY. E.C. SHALL COORDINATE EXACT MOUNTING LOCATION OF RECEPTABLES WITH OWNER PRIOR TO INSTALLATION (TYPICAL FOR MOTHER ROOM 110).
 - ELECTRICAL CONTRACTOR SHALL REFER TO GROW LIGHT RECEPTACLE MOUNTING DETAIL ON THIS SHEET FOR MOUNTING DETAILS. E.C. SHALL COORDINATE EXACT MOUNTING LOCATION WITH OWNER PRIOR TO INSTALLATION.
 - ELECTRICAL CONTRACTOR SHALL REFER TO DETAIL No. 11 ON DRAWING E0.8 FOR WIRING DETAILS ON MAXI CONTROLLER AND GROW LIGHTS. GROW LIGHTS AND MAXI CONTROLLER SHALL BE INTERCONNECTED VIA CAT6 CABLE FOR ZONE CONTROL.
 - ELECTRICAL CONTRACTOR SHALL INSTALL OWNER PROVIDED TYPE E FIXTURES AS INDICATED.

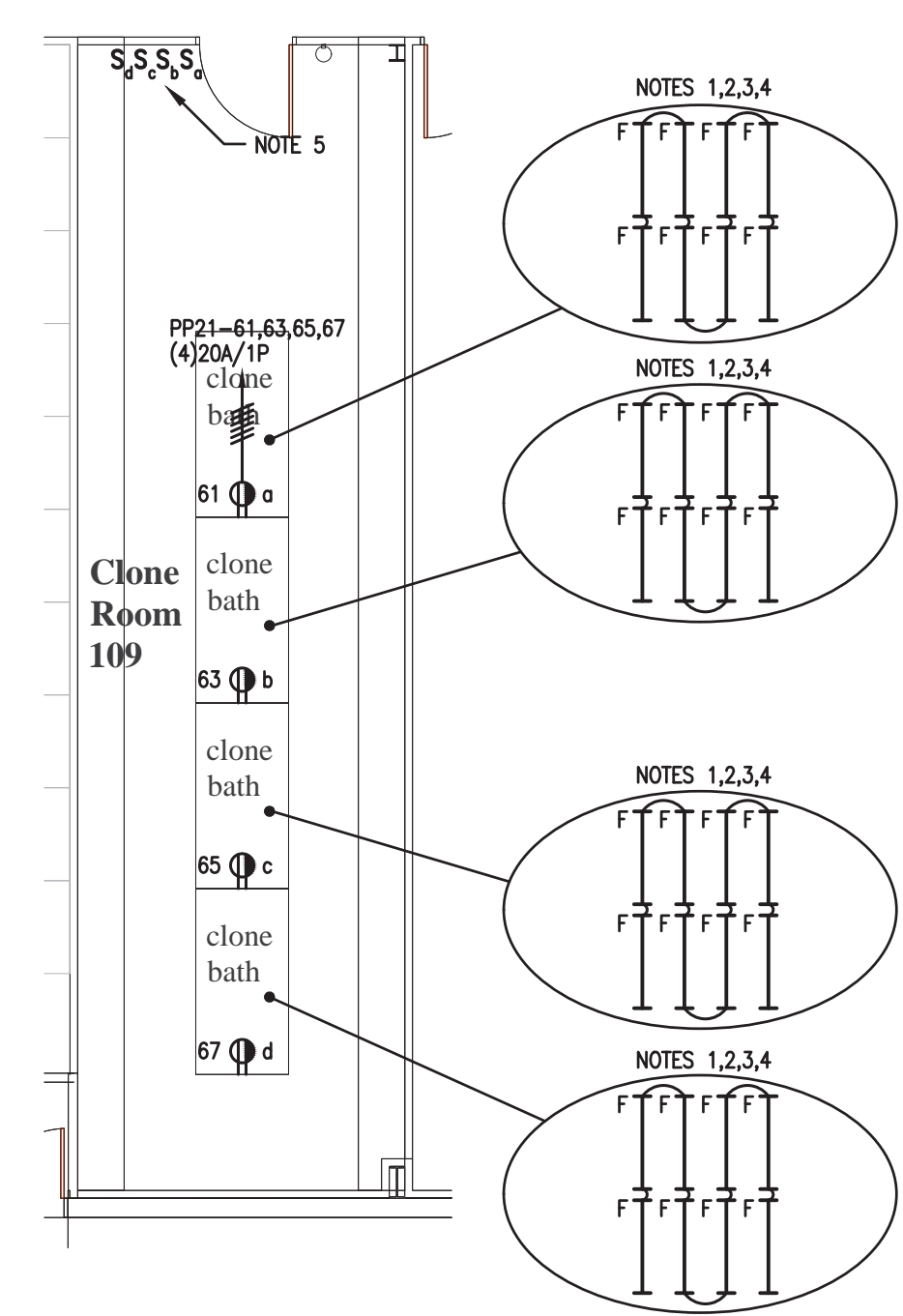

4 ELECTRICAL - Clone Room 109
SCALE: 1/8" = 1'-0" TIERS 1,2,3,4

- NOTES:**
- ELECTRICAL CONTRACTOR SHALL PROVIDE ALL CONDUIT, CONDUCTORS AND RECEPTABLES ASSOCIATED WITH TYPE F FIXTURES AT EACH CLONE BATH SECTION. CLONE BATH SECTION SHALL INCLUDE (32) TYPE F FIXTURES; (8) FIXTURES PER TIER AND (4) TIERS.
 - BRANCH CIRCUIT AND SWITCHING ZONE INDICATED SHALL BE FOR ENTIRE CLONE BATH SECTION (4 TIERS). E.C. SHALL COORDINATE EXACT MOUNTING LOCATION OF RECEPTABLES WITH OWNER PRIOR TO INSTALLATION.
 - ELECTRICAL CONTRACTOR SHALL UTILIZE POWER CORD PROVIDED WITH TYPE F FIXTURE TO PLUG INTO SWITCHED RECEPTACLE. SWITCHED RECEPTACLE SHALL BE PROVIDED AT EACH TIER AND BE CONNECTED TO THE SAME SWITCH AND BRANCH CIRCUIT INDICATED (4 TOTAL).
 - ELECTRICAL CONTRACTOR SHALL UTILIZE JUMPER CABLE PROVIDED WITH TYPE F FIXTURE TO INTERCONNECT FIXTURES (TYPICAL).
 - ELECTRICAL CONTRACTOR SHALL PROVIDE WEATHERPROOF IN-USE CLEAR COVER AS MANUFACTURED BY HUBBELL, OR EQUAL; HUBBELL No. MM410C, MOUNTING HEIGHT 48" TO CENTERLINE OF TOGGLE SWITCH IN "ON" POSITION.

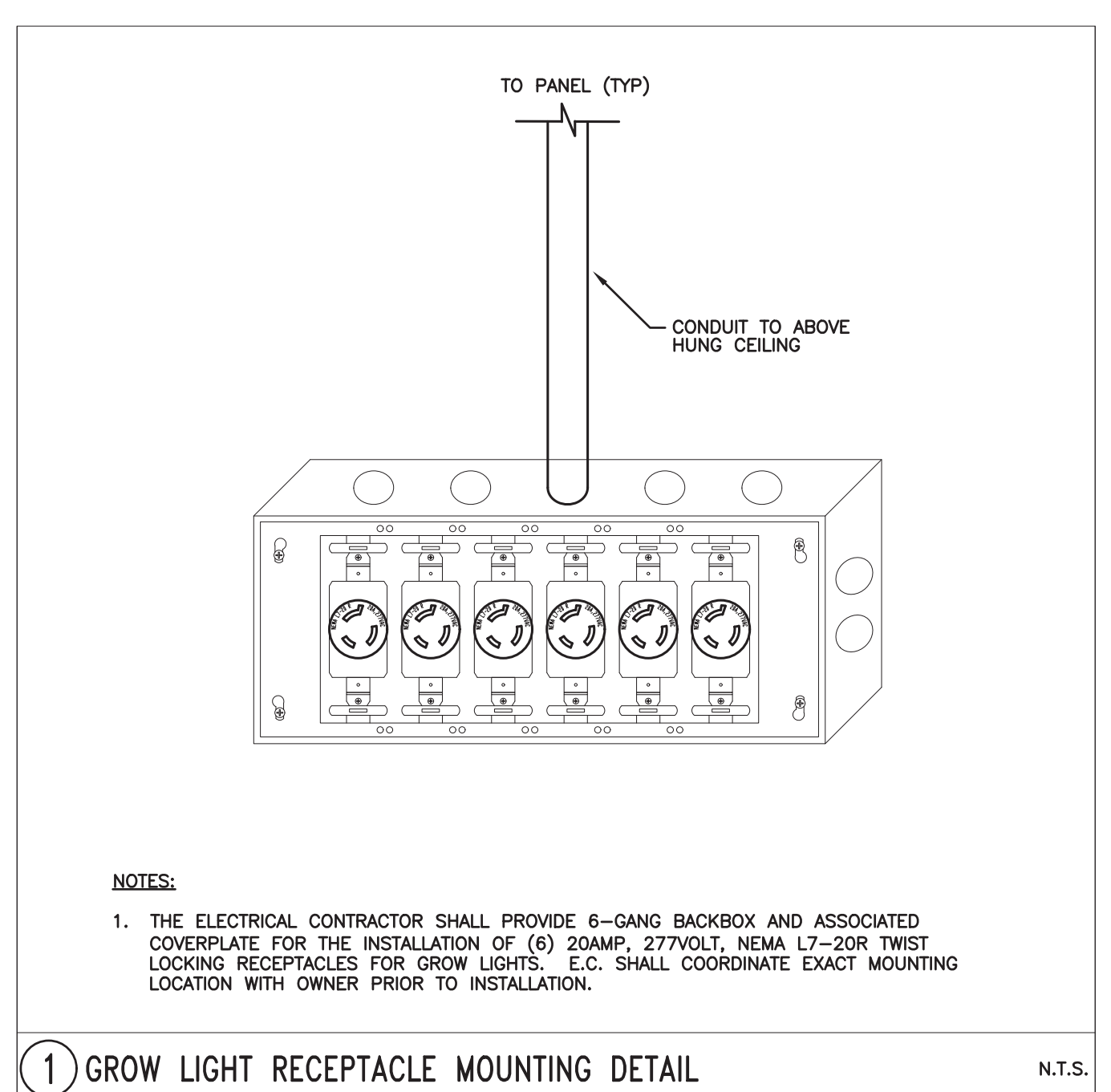

Sanctuary Medicinals, Inc. Phased Pricing 18 August 2017
 234 Taylor Street Littleton, Massachusetts
 Tony Fallon Architecture
 501 Barn Door Gap Strafford, New Hampshire 03884-6233
 603 269 3206 tony@tonyfallon.com
 Licensed by New Hampshire, Maine, & Massachusetts

1 ELECTRICAL - Grow Rooms 103, 104, 105
 SCALE: 1/8" = 1'-0" TIERS 1,2,3

- NOTES:**
- ELECTRICAL CONTRACTOR SHALL PROVIDE ALL CONDUIT, CONDUCTORS AND RECEPTACLES ASSOCIATED WITH TYPE D FIXTURES AT RACK SECTIONS. RACK SECTION SHALL INCLUDE (6) TYPE D FIXTURES; (2) FIXTURES PER TIER AND (3) TIERS. BRANCH CIRCUIT AND MAXI CONTROLLER ZONE INDICATED SHALL BE FOR ENTIRE RACK SECTION (3 TIERS). E.C. SHALL COORDINATE EXACT MOUNTING LOCATION OF RECEPTACLES WITH OWNER PRIOR TO INSTALLATION.
 - ELECTRICAL CONTRACTOR SHALL REFER TO GROW LIGHT RECEPTACLE MOUNTING DETAIL ON THIS SHEET FOR MOUNTING DETAILS. E.C. SHALL COORDINATE EXACT MOUNTING LOCATION WITH OWNER PRIOR TO INSTALLATION.
 - ELECTRICAL CONTRACTOR SHALL REFER TO DETAIL No. 11 ON DRAWING E0.8 FOR WIRING DETAILS ON MAXI CONTROLLER AND GROW LIGHTS. GROW LIGHTS AND MAXI CONTROLLER SHALL BE INTERCONNECTED VIA CAT6 CABLE FOR ZONE CONTROL.
 - ELECTRICAL CONTRACTOR SHALL INSTALL OWNER PROVIDED TYPE D FIXTURES AS INDICATED.

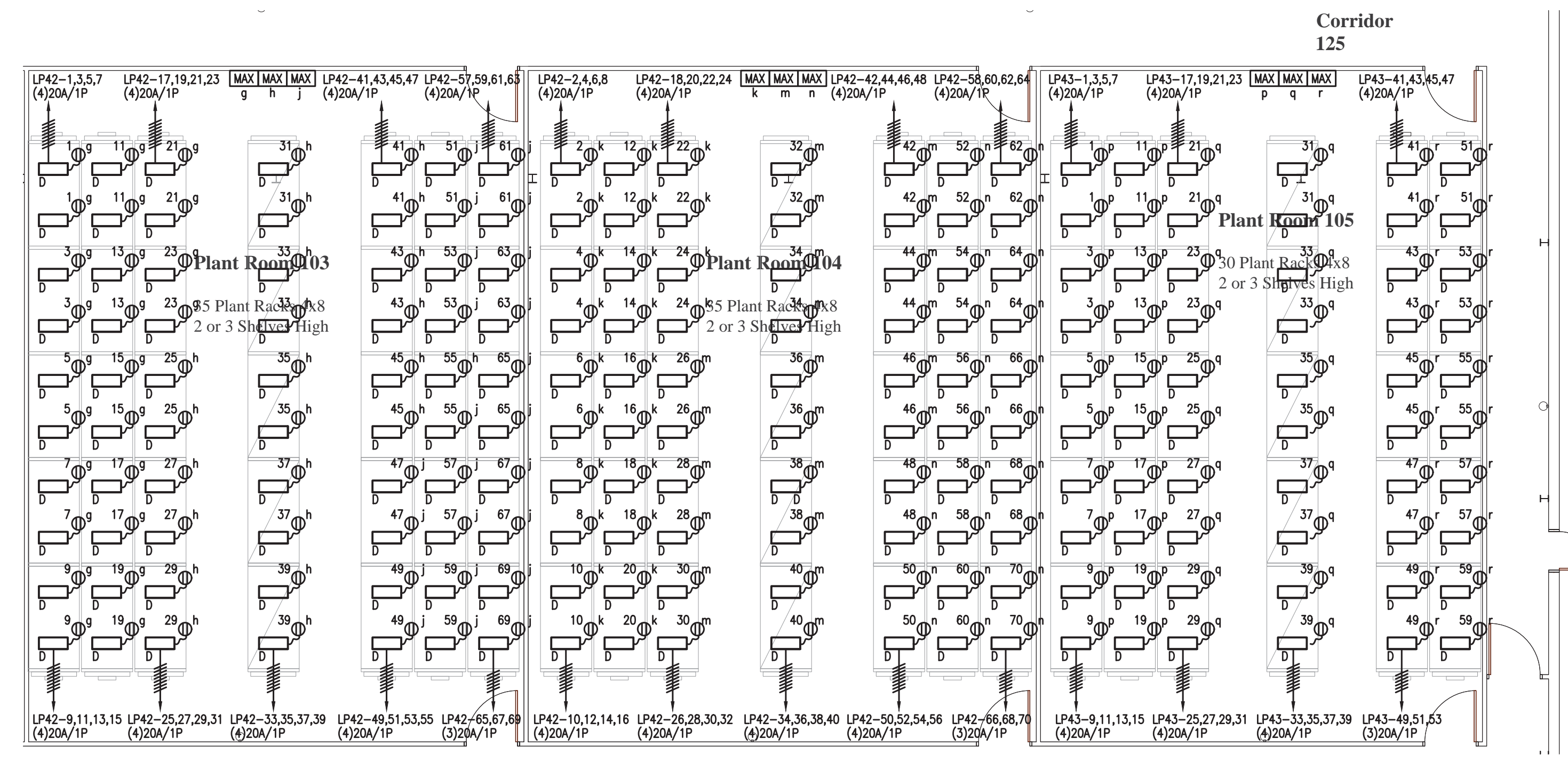

LIGHTING FIXTURE SCHEDULE						
FIXTURE TYPE	DESCRIPTION	MANUFACTURER AND CATALOG NUMBER	LAMPS			VOLTAGE
			No.	WATTAGE	TYPE	
D	DUAL FULL SPECTRUM GROW LIGHT WITH OPEN REFLECTOR (ALPHA OPTICS 98), DIMLUX XTREME 630W BALLAST, DIMMABLE	DIMLUX # 630W EXPERT SERIES	1	630	CDM-T ELITE 630W/930	277
G	SURFACE MOUNTED VAPORLIGHT WITH SHOCK RESISTANT GLASS GLOBE, PROVIDE WITH ILLUMINANT SUPER GREEN LED LIGHT BULB	PHILIPS STANCO # VK11K	1	5	SUPER GREEN LED	120

* LIGHT FIXTURE SHALL BE PROVIDED BY OWNER

2 ELECTRICAL - Grow Rooms 106, 107, 108
 SCALE: 1/8" = 1'-0" TIER 1

- NOTES:**
- ELECTRICAL CONTRACTOR SHALL PROVIDE ALL CONDUIT, CONDUCTORS AND RECEPTACLES ASSOCIATED WITH TYPE D FIXTURES AT RACK SECTIONS. RACK SECTION SHALL INCLUDE (4) TYPE D FIXTURES; (2) FIXTURES PER TIER AND (2) TIERS. BRANCH CIRCUIT AND MAXI CONTROLLER ZONE INDICATED SHALL BE FOR TIER 1 ONLY. E.C. SHALL COORDINATE EXACT MOUNTING LOCATION OF RECEPTACLES WITH OWNER PRIOR TO INSTALLATION.
 - ELECTRICAL CONTRACTOR SHALL REFER TO GROW LIGHT RECEPTACLE MOUNTING DETAIL ON THIS SHEET FOR MOUNTING DETAILS. E.C. SHALL COORDINATE EXACT MOUNTING LOCATION WITH OWNER PRIOR TO INSTALLATION.
 - ELECTRICAL CONTRACTOR SHALL REFER TO DETAIL No. 11 ON DRAWING E0.8 FOR WIRING DETAILS ON MAXI CONTROLLER AND GROW LIGHTS. GROW LIGHTS AND MAXI CONTROLLER SHALL BE INTERCONNECTED VIA CAT6 CABLE FOR ZONE CONTROL.
 - ELECTRICAL CONTRACTOR SHALL INSTALL OWNER PROVIDED TYPE D FIXTURES AS INDICATED.

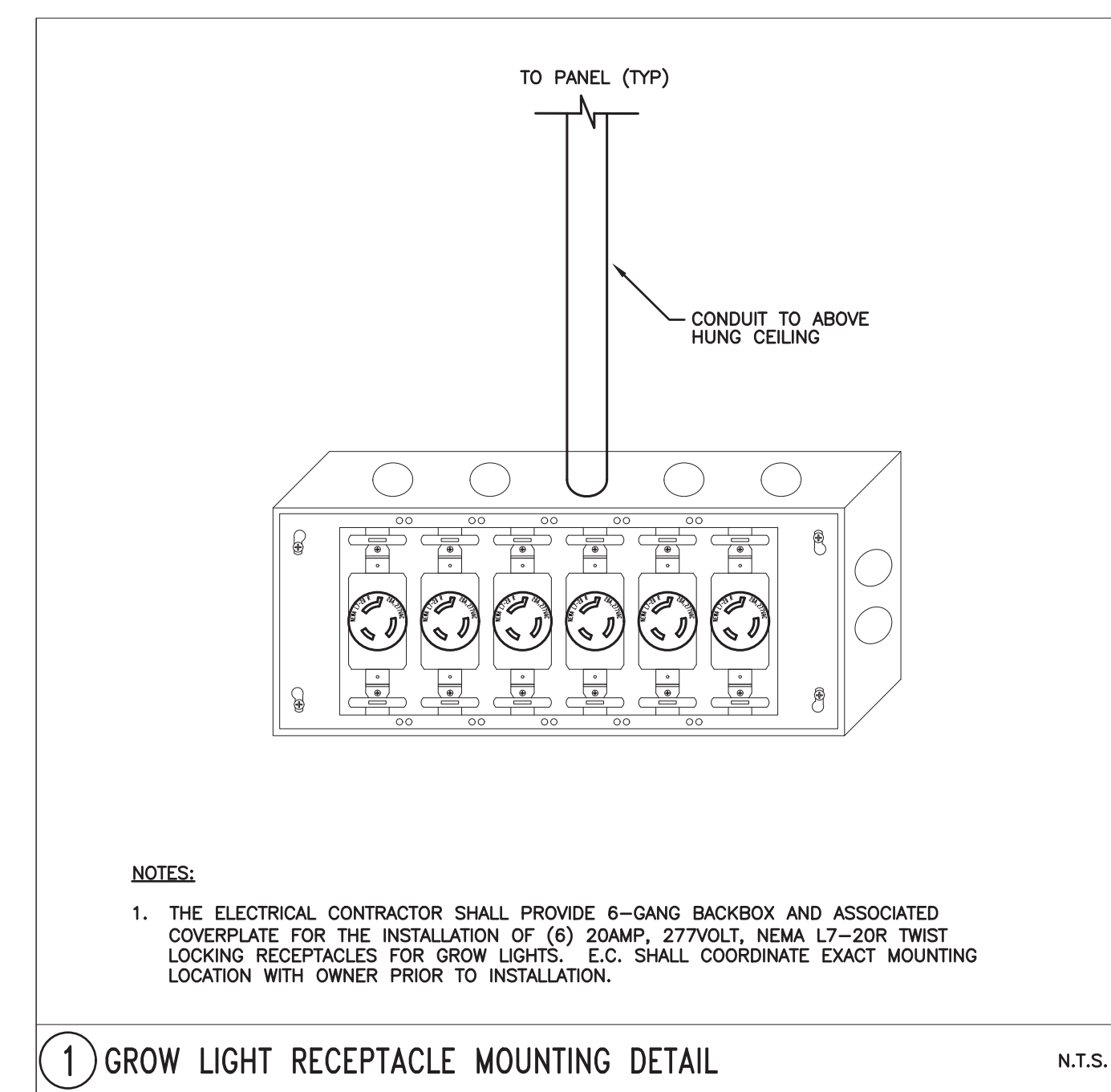
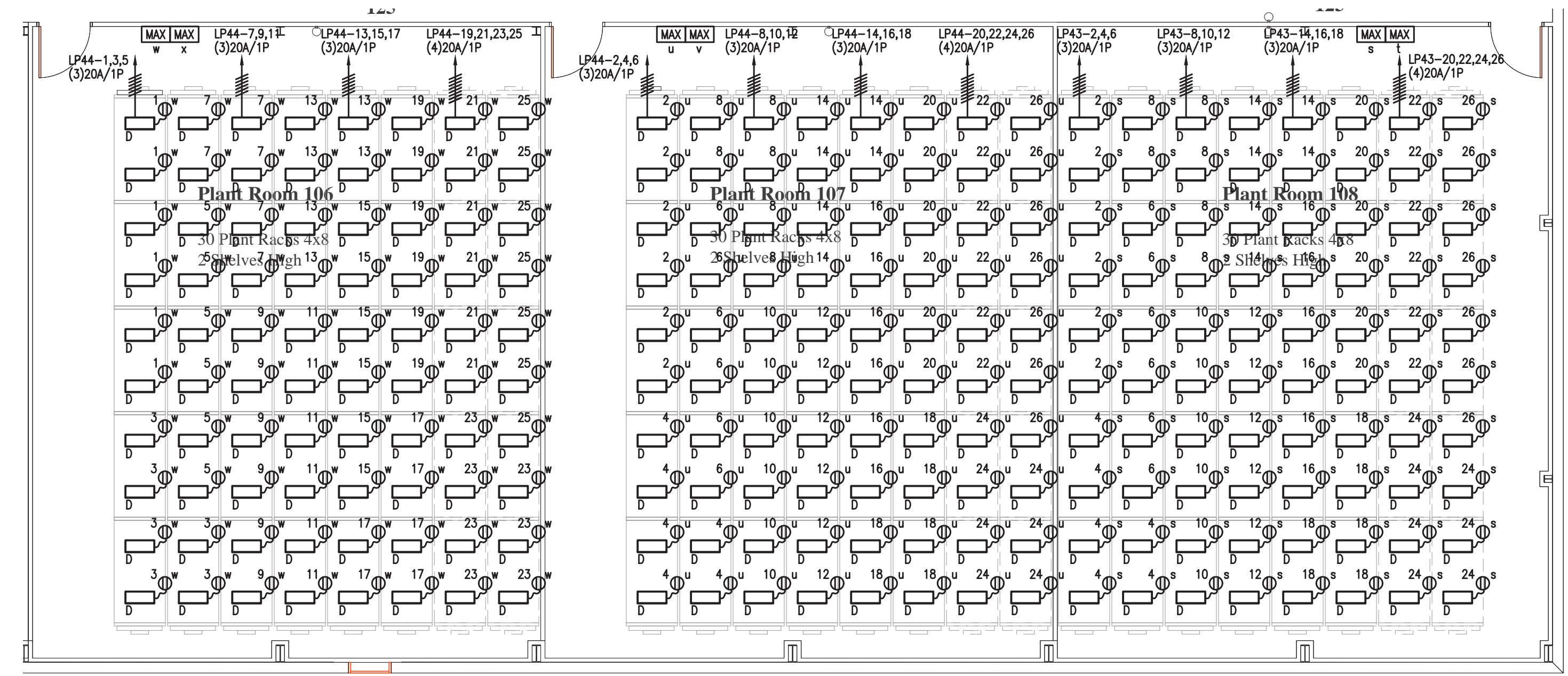

3 ELECTRICAL - Grow Rooms 106, 107, 108
 SCALE: 1/8" = 1'-0" TIER 2

- NOTES:**
- ELECTRICAL CONTRACTOR SHALL PROVIDE ALL CONDUIT, CONDUCTORS AND RECEPTACLES ASSOCIATED WITH TYPE D FIXTURES AT RACK SECTIONS. RACK SECTION SHALL INCLUDE (4) TYPE D FIXTURES; (2) FIXTURES PER TIER AND (2) TIERS. BRANCH CIRCUIT AND MAXI CONTROLLER ZONE INDICATED SHALL BE FOR TIER 1 ONLY. E.C. SHALL COORDINATE EXACT MOUNTING LOCATION OF RECEPTACLES WITH OWNER PRIOR TO INSTALLATION.
 - ELECTRICAL CONTRACTOR SHALL REFER TO GROW LIGHT RECEPTACLE MOUNTING DETAIL ON THIS SHEET FOR MOUNTING DETAILS. E.C. SHALL COORDINATE EXACT MOUNTING LOCATION WITH OWNER PRIOR TO INSTALLATION.
 - ELECTRICAL CONTRACTOR SHALL REFER TO DETAIL No. 11 ON DRAWING E0.8 FOR WIRING DETAILS ON MAXI CONTROLLER AND GROW LIGHTS. GROW LIGHTS AND MAXI CONTROLLER SHALL BE INTERCONNECTED VIA CAT6 CABLE FOR ZONE CONTROL.
 - ELECTRICAL CONTRACTOR SHALL INSTALL OWNER PROVIDED TYPE D FIXTURES AS INDICATED.

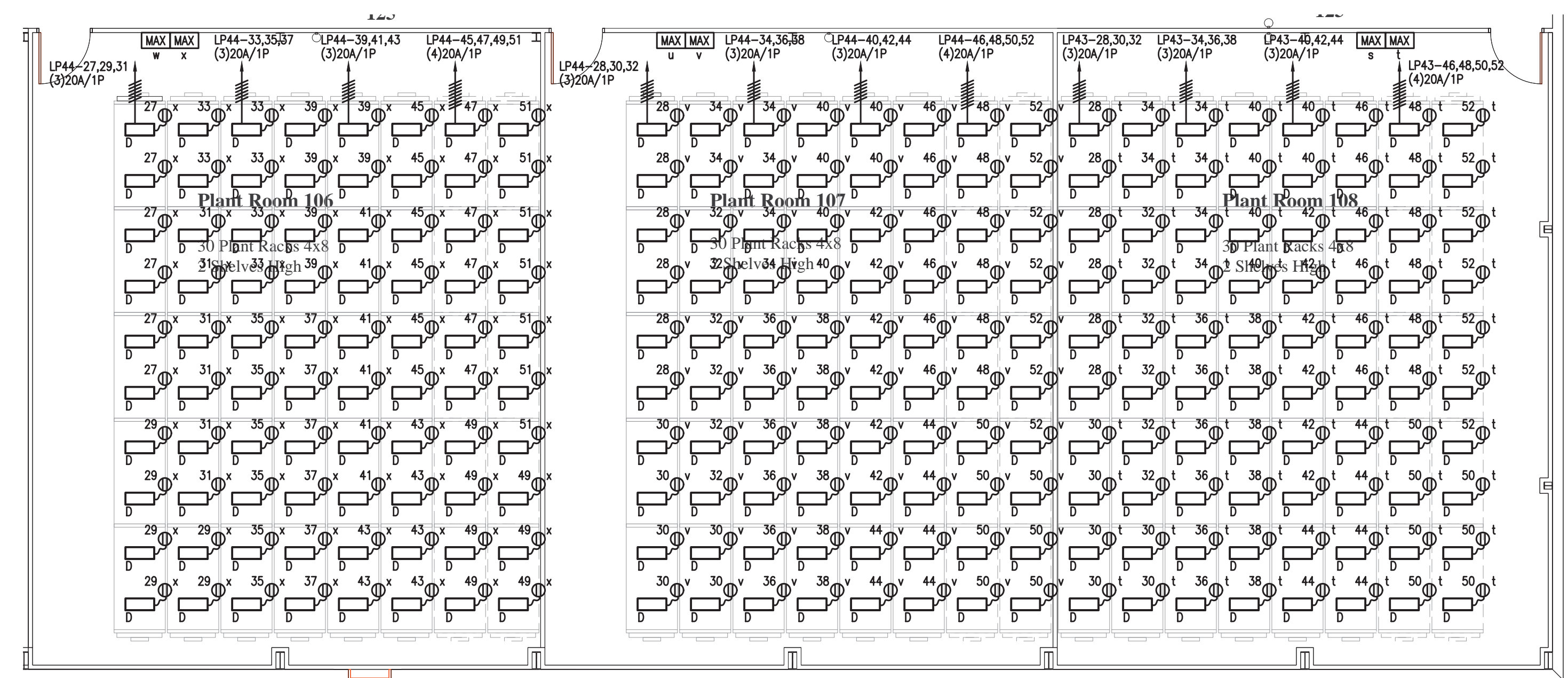

GROW LIGHTS SHALL BE PROGRAMMED PER THE FOLLOWING DURING EMERGENCY POWER:

- ONLY (2) PLANT ROOMS SHALL RUN SIMULTANEOUSLY ALONG WITH MOTHER ROOM 110 AND CLONE ROOM 109:
 - MOTHER, CLONE, PLANT 101, PLANT 102
 - MOTHER, CLONE, PLANT 103, PLANT 104
 - MOTHER, CLONE, PLANT 105, PLANT 106
 - MOTHER, CLONE, PLANT 107, PLANT 108
- PLANT ROOM LIGHTING SHALL BE PROGRAMMED TO OPERATE AS EVERY OTHER FIXTURE VIA MAXI CONTROLLER.

Tony Fallon Architecture
 501 Barn Door Gap Strafford, New Hampshire 03884-6233
 603 269 3206
 tonyfallon.com Licensed by New Hampshire, Maine, & Massachusetts
 tony@tonyfallon.com

Phase 2 VE
 12 April 2018

Sanctuary Medicinals, Inc.
 234 Taylor Street
 Littleton, Massachusetts

Electrical
 Grow Light
 Part Plans

2 General venting

Table 2B Direct Vent Minimum / Maximum Allowable Air / Vent Lengths

Model	AIR INLET			VENT			Input De-Rate per 25 feet of Vent
	Air Intake Diameter	Air Intake Min. Length	Air Intake Max. Length	Vent Diameter	Vent Min. Length	Vent Max. Length	
FB 0751	6"	12'	100'	6"	18'	100'	0%
FB 1001	6"	12'	100'	6"	18'	100'	0%
FB 1251	6"	12'	100'	8"	18'	100'	0%
FB 1501	8"	12'	100'	8"	18'	100'	0%
FB 1751	8"	12'	100'	8"	18'	100'	0%
FB 2001	8"	12'	100'	8"	18'	100'	0%

Table 2C Room Air Minimum / Maximum Allowable Air / Vent Lengths

Model	Vent Diameter	Vent Min. Length	Vent Max. Length	Input De-Rate per 25 feet of Vent
FB 0751	6"	18'	100'	0%
FB 1001	6"	18'	100'	0%
FB 1251	8"	18'	100'	0%
FB 1501	8"	18'	100'	0%
FB 1751	8"	18'	100'	0%
FB 2001	8"	18'	100'	0%

2 General venting *(continued)*

Install vent and combustion air piping

⚠ DANGER

The Crest must be vented and supplied with combustion and ventilation air as described in this section. Ensure the vent and air piping and the combustion air supply comply with these instructions regarding vent system, air system, and combustion air quality. See also Section 1 of this manual.

Inspect finished vent and air piping thoroughly to ensure all are airtight and comply with the instructions provided and with all requirements of applicable codes.

Failure to provide a properly installed vent and air system will cause severe personal injury or death.



Air inlet pipe materials:

The air inlet pipe(s) must be sealed. Choose acceptable combustion air inlet pipe materials from the following list:

ABS, PVC, or CPVC

Dryer Vent or Sealed Flexible Duct (not recommended for rooftop air inlet)

Galvanized steel vent pipe with joints and seams sealed as specified in this section.

Type "B" double-wall vent with joints and seams sealed as specified in this section.

AL29-4C, stainless steel material to be sealed to specification of its manufacturer.

*Plastic pipe may require an adapter (not provided) to transition between the air inlet connection on the appliance and the plastic air inlet pipe.

⚠ WARNING

Using vent or air intake materials other than those specified, failure to properly seal all seams and joints or failure to follow vent pipe manufacturer's instructions can result in personal injury, death or property damage. Mixing of venting materials will void the warranty and certification of the appliance.

NOTICE

The use of double-wall vent or insulated material for the combustion air inlet pipe is recommended in cold climates to prevent the condensation of airborne moisture in the incoming combustion air.

Sealing of Type "B" double-wall vent material or galvanized vent pipe material used for air inlet piping on a sidewall or vertical rooftop Combustion Air Supply System:

- Seal all joints and seams of the air inlet pipe using either Aluminum Foil Duct Tape meeting UL Standard 723 or 181A-P or a high quality UL Listed silicone sealant such as those manufactured by Dow Corning or General Electric.
- Do not install seams of vent pipe on the bottom of horizontal runs.
- Secure all joints with a minimum of three sheet metal screws or pop rivets. Apply Aluminum Foil Duct Tape or silicone sealant to all screws or rivets installed in the vent pipe.
- Ensure that the air inlet pipes are properly supported.

The PVC, CPVC, or ABS air inlet pipe should be cleaned and sealed with the pipe manufacturer's recommended solvents and standard commercial pipe cement for the material used. The ABS, PVC, CPVC, Dryer Vent or Flex Duct air inlet pipe should use a silicone sealant to ensure a proper seal at the appliance connection and the air inlet cap connection. Dryer vent or flex duct should use a screw type clamp to seal the vent to the appliance air inlet and the air inlet cap. Proper sealing of the air inlet pipe ensures that combustion air will be free of contaminants and supplied in proper volume.

2 General venting

When a sidewall or vertical rooftop combustion air supply system is disconnected for any reason, the air inlet pipe must be resealed to ensure that combustion air will be free of contaminants and supplied in proper volume.

⚠ DANGER Failure to properly seal all joints and seams as required in the air inlet piping may result in flue gas recirculation, spillage of flue products and carbon monoxide emissions causing severe personal injury or death.

Vent and air piping

The Crest is certified as a Category II/IV boiler. **This product has been approved for use with stainless steel vent systems.** All venting systems used with a Crest boiler must be suitable for Category IV operation except for factory approved common vent systems operating as allowed in the Common Venting Section on page 19.

⚠ WARNING Use only the materials, vent systems, and terminations listed in Table 2A-1. DO NOT mix vent systems of different types or manufacturers, unless listed in this manual. Failure to comply could result in severe personal injury, death, or substantial property damage.

NOTICE Installations must comply with applicable national, state, and local codes. Stainless steel vent systems must be listed as a UL-1738 approved system for the United States and a ULC-S636 approved system for Canada.

NOTICE Installation of a stainless steel vent system should adhere to the stainless steel vent manufacturer's installation instructions supplied with the vent system.

NOTICE The Crest is supplied with an integral FasNSeal vent connector (FIG. 2-1). The installer must use a specific vent starter adapter supplied by the vent manufacturer to adapt to different vent systems.

Air intake/vent connections

1. **Combustion Air Intake Connector** (FIG. 2-1) - Used to provide combustion air directly to the unit from outdoors. A fitting is provided with the unit for final connection. Combustion air piping must be supported per guidelines listed in the National Mechanical Code, Section 305, Table 305.4 or as local codes dictate.
2. **Vent Connector** (FIG. 2-1) - Used to provide a passageway for conveying combustion gases to the outside. A transition fitting is provided on the unit for final connection. Vent piping must be supported per the National Building Code, Section 305, Table 305.4 or as local codes dictate.

Figure 2-1 Combustion Air Adapter

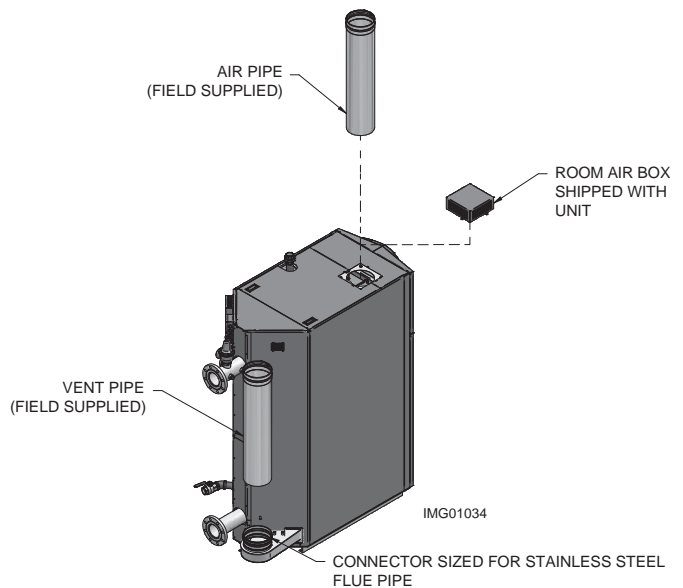

The Crest uses model specific combustion air intake and vent piping sizes as detailed in Tables 2B and 2C on page 17.

NOTICE Increasing or decreasing combustion air or vent piping to sizes not specified in this manual is not authorized.

Table 2A-1 Approved Stainless Steel Vent Manufacturers

Approved Stainless Steel Vent Manufacturers	
Make	Model
ProTech Systems (Dura-Vent Co.)	FasNSeal Vent
Z-Flex (Nova Flex Group)	Z-Vent
Heat Fab (Selkirk Corporation)	Saf-T Vent
Metal Fab	Corr/Guard
Securities Chimneys International	Secure Seal SS
Schebler Chimney Systems	eVent
ICC	VIC
Jeremias	--

2 General venting

Table 2A-2 Approved Stainless Steel Terminations and Adapters - Category IV

Model	ProTech			Z Flex			Heat Fab		
	Adapter	Intake		Adapter	Intake		Adapter	Flue	Intake
751-1001	*See note	810003269		2SVDSA06	2SVEE0690		9601MAD	CCK06TM	9690 9692
1251	*See note	810003281		2SVDSA06	2SVEE0690		9801MAD	CCK08TM	9690 9692
1501-2001	*See note	810003357 810003369		2SVDSA08	2SVEE0890		9801MAD	CCK08TM	9890 9892
Model	Metal-Fab			Security Chimney			ICC		
	Adapter	Flue	Intake	Adapter	Flue	Intake	Adapter	Flue	Intake
751-1001	6FCGPVCA	MC 6-36"	6FCGSW90L	SS6PVCU	SS0MCU 4" - 24"	SS6ST90AU SSD0STAU 4" - 24"	HE-6DSA-F	HE-6MC-F HE-6RC-F	HE-6E90-F HE-6SCR-F
1251	8FCGLCA	MC 6-36"	6FCGSW90L	SS8CRESTU	SS0MCU 4" - 24"	SS6ST90AU SSD0STAU 4" - 24"	HE-8DSA-F	HE-8SCR-F HE-8MC-F	HE-6E90-F HE-6SCR-F
1501-2001	8FCGLCA	MC 6-36"	8FCGSW90	SS8CRESTU	SS0MCU 4" - 24"	SSE8E90U SD0STAU 4" - 24"	HE-8DSA-F	HE-8SCR-F HE-8MC-F	HE-8E90-F HE-8SCR-F
Model	Jeremias			*No adapter needed when using Standard FNS Vent Length.					
	Adapter	Flue	Intake						
751-1001	SWKL6-KLC	SWKL6-WRC	SWKL6-90ET						
1251	SWKL8-KLC	SWKL8-WRC	SWKL6-90ET						
1501-2001	SWKL8-KLC	SWKL8-WRC	SWKL8-90ET						

2 General venting *(continued)*

Table 2E PVC/CPVC Vent Pipe and Fittings

Approved PVC/CPVC Vent Pipe and Fittings		
Item	Material	Standard
Vent pipe	PVC Schedule 40, 80	ANSI/ASTM D1785
	PVC - DWV	ANSI/ASTM D2665
	CPVC Schedule 40, 80	ANSI/ASTM F441
Vent fittings	PVC Schedule 40	ANSI/ASTM D2466
	PVC Schedule 80	ANSI/ASTM D2467
	CPVC Schedule 80	ANSI/ASTM F439
	PVC - DWV	ANSI/ASTM D2665
Pipe Cement / Primer	PVC	ANSI/ASTM D2564
	CPVC	ANSI/ASTM F493
NOTICE: DO NOT USE CELLULAR (FOAM) CORE PIPE		

NOTE: In Canada, CPVC and PVC vent pipe, fittings and cement/primer must be ULC-S636 certified.

1. Work from the boiler to vent or air termination. Do not exceed the lengths given in this manual for the air or vent piping.
2. Cut pipe to the required lengths and deburr the inside and outside of the pipe ends.
3. Chamfer outside of each pipe end to ensure even cement distribution when joining.
4. Clean all pipe ends and fittings using a clean dry rag. (Moisture will retard curing and dirt or grease will prevent adhesion.)

5. Dry fit vent or air piping to ensure proper fit up before assembling any joint. The pipe should go a third to two-thirds into the fitting to ensure proper sealing after cement is applied.
6. Priming and Cementing:
 - a. Handle fittings and pipes carefully to prevent contamination of surfaces.
 - b. Apply a liberal even coat of primer to the fitting socket and to the pipe end to approximately 1/2" beyond the socket depth.
 - c. Apply a second primer coat to the fitting socket.
 - d. While primer is still wet, apply an even coat of approved cement to the pipe equal to the depth of the fitting socket along with an even coat of approved cement to the fitting socket.
 - e. Apply a second coat of cement to the pipe.
 - f. While the cement is still wet, insert the pipe into the fitting, if possible twist the pipe a 1/4 turn as you insert it. **NOTE:** If voids are present, sufficient cement was not applied and joint could be defective.
 - g. Wipe excess cement from the joint removing ring or beads as it will needlessly soften the pipe.

Figure 2-2 Near Boiler PVC/CPVC Venting - Models 751 - 1001 (Flue connections from the factory are sized for stainless steel venting.)

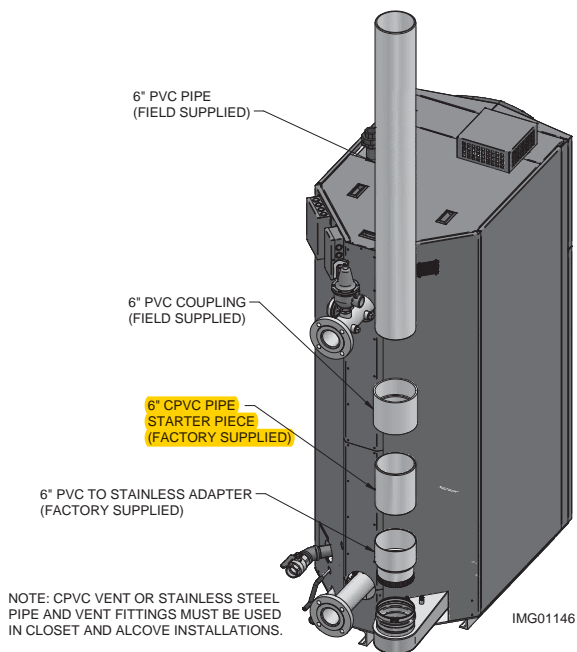
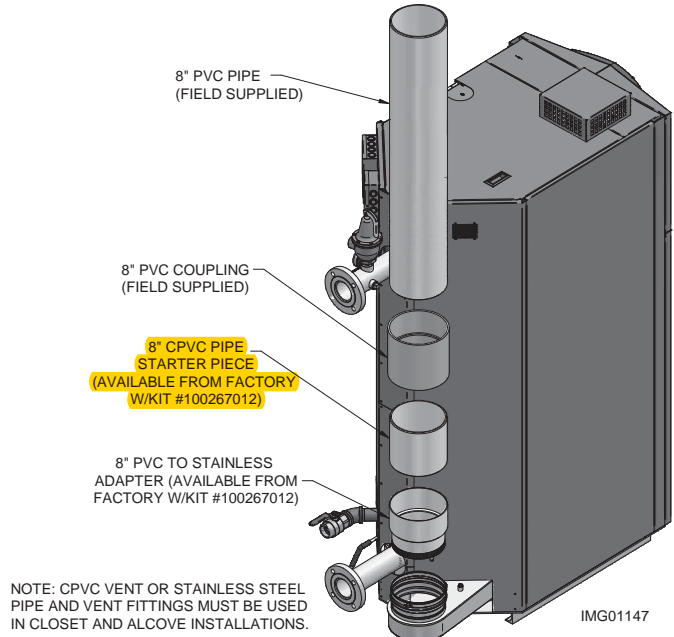

Figure 2-3 Near Boiler PVC/CPVC Venting - Model 1251 - 2001 (Flue connections from the factory are sized for stainless steel venting.)



2 General venting

Polypropylene

This product has been approved for use with polypropylene vent with the manufacturers listed in Table 2F.

NOTICE

Factory installed vent connections are sized for stainless steel venting.

All terminations must comply with listed options in this manual and be a single-wall vent offering.

For support and special connections required, see the manufacturer's instructions. All vent is to conform to standard diameter and equivalent length requirements established.

When determining equivalent combustion air and vent length for polypropylene single-wall piping contact the manufacturer.

Table 2F Polypropylene Vent Pipe and Fittings

Approved Polypropylene Vent Manufacturers	
Make	Model
Centrotherm Eco Systems	InnoFlue SW/Flex
DuraVent (M & G Group)	PolyPro Single-Wall / PolyPro Flex

NOTICE

The installer must use a specific vent starter adapter at the flue collar connection. The adapter is supplied by the vent manufacturer to adapt to its vent system. See Table 2F for approved vent adapters. Discard CPVC starter piece.

NOTICE

All vent connections **MUST** be secured by the vent manufacturer's joint connector (FIG. 2-4).

WARNING

Insulation should not be used on polypropylene venting materials. The use of insulation will cause increased vent wall temperatures, which could result in vent pipe failure.

WARNING

Use only the adapters and vent system listed in Tables 2F and 2G. **DO NOT** mix vent systems of different types or manufacturers. Failure to comply could result in severe personal injury, death, or substantial property damage.

NOTICE

Installations must comply with applicable national, state, and local codes. For Canadian installation, polypropylene vent must be listed as a ULC-S636 approved system.

NOTICE

Installation of a polypropylene vent system should adhere to the vent manufacturer's installation instructions supplied with the vent system.

Figure 2-4 Near Boiler Polypropylene Venting

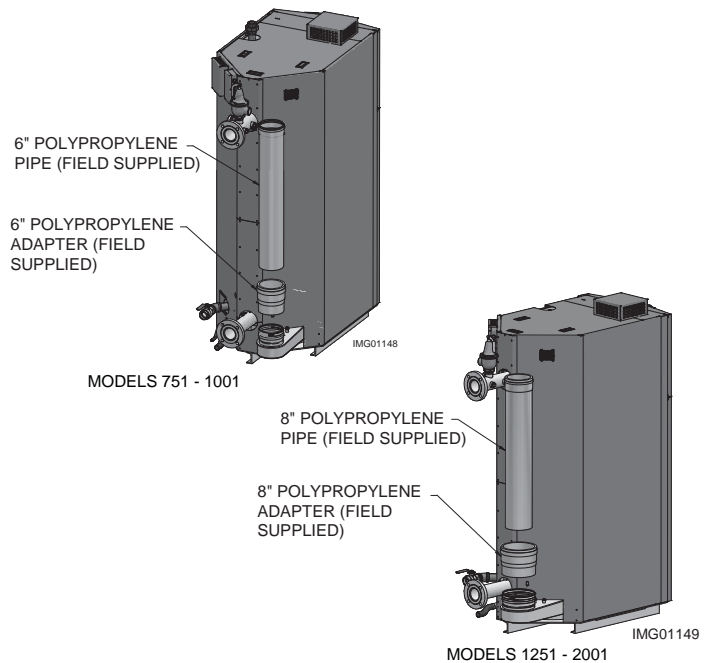

Table 2G Approved Polypropylene Terminations

Model	Manufacturer	Vent Model	Vent Type	Adapter Number	Joint Connector	Sidewall Kit*	Retaining Bracket / Adapter*
751-1001	Centrotherm Eco Systems	Innoflue	Single-Wall Flex	ISAAL0606	--	--	IATP0606 / ISTAGL0606
	DuraVent (M & G)	PolyPro	Single-Wall Flex	FSA-06M-PPF	--	6PPS-HLKL	--
1251-2001	Centrotherm Eco Systems	Innoflue	Single-Wall	ISAA0808	--	--	--
	DuraVent (M & G)	PolyPro	Single-Wall	FSA-08M-8PPF	--	8PPS-HSTL	--

* These parts are only needed if the sidewall termination assembly is used (see FIG. 4-1C on page 25).

3 Vertical direct venting

Vent/air termination – vertical

⚠ WARNING Follow instructions below when determining vent location to avoid possibility of severe personal injury, death or substantial property damage.

⚠ WARNING Do not connect any other appliance to the vent pipe or multiple boilers to a common vent pipe except as noted in Section 2 on page 19. Failure to comply could result in severe personal injury, death, or substantial property damage.

NOTICE Installation must comply with local requirements and with the National Fuel Gas Code, NFPA 54 / ANSI Z223.1 - latest edition for U.S. installations or CSA B149.1 Installation Code for Canadian installations.

Determine location

Locate the vent/air terminations using the following guidelines:

1. The total length of piping for vent or air must not exceed the limits given in the General Venting Section on page 17 of this manual.
2. The vent must terminate at least 3 feet above the highest place in which the vent penetrates the roof and at least 2 feet above any part of a building within 10 horizontal feet.
3. The air piping must terminate in a down-turned 180° return pipe no further than 2 feet (.6 m) from the center of the vent pipe. This placement avoids recirculation of flue products into the combustion air stream.
4. The vent piping must terminate in an up-turned coupling as shown in FIG. 3-1. The top of the coupling or the rain cap must be at least 36" (914 mm) above the air intake. The air inlet pipe and vent pipe can be located in any desired position on the roof, but must always be no further than 2 feet (.6 m) apart and with the vent termination at least 36" (914 mm) above the air intake.

⚠ WARNING Rooftop vent and air inlet terminations must terminate in the same pressure zone, unless vertical vent sidewall air is set up as shown in the General Venting - Vertical Vent, Sidewall Air Section.

Figure 3-1 Vertical Termination of Air and Vent

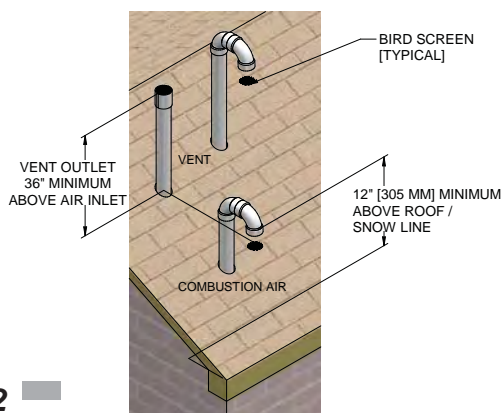
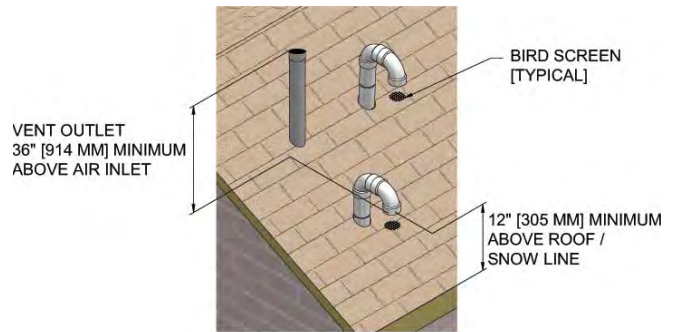

Figure 3-2 Vertical Termination of Air and Vent w/Rain Cap



5. Locate terminations so they are not likely to be damaged by foreign objects, such as stones or balls, or subject to buildup of leaves or sediment.

Prepare roof penetrations

1. Air pipe penetration:
 - a. Cut a hole for the air pipe. Size the air pipe hole as close as desired to the air pipe outside diameter.
2. Vent pipe penetration:
 - a. Cut a hole for the vent pipe. For either combustible or noncombustible construction, size the vent pipe hole per the vent manufacturer's instructions.
 - b. Insert a galvanized metal thimble in the vent pipe hole (when required by local codes).
3. Space the air and vent holes to provide the minimum spacing shown in FIG. 3-1.
4. Follow all local codes for isolation of vent pipe when passing through floors, ceilings, and roofs.
5. Provide flashing and sealing boots sized for the vent pipe and air pipe.

Termination and fittings

1. Prepare the vent termination coupling and the air termination elbow (FIG. 3-1) by inserting bird screens. Bird screens should be obtained locally.
2. The air piping must terminate in a down-turned 180° return bend as shown in FIG. 3-1. Locate the air inlet pipe no further than 2 feet (.6 m) from the center of the vent pipe. This placement avoids recirculation of flue products into the combustion air stream.

3 Vertical direct venting

3. The vent piping must terminate in an up-turned coupling as shown in FIG. 3-1. The top of the coupling or the rain cap must be at least 36" (914 mm) above the air intake. The air inlet pipe and vent pipe can be located in any desired position on the roof, but must always be no further than 2 feet (.6 m) apart and with the vent termination at least 36" (914 mm) above the air intake.
4. Maintain the required dimensions of the finished termination piping as shown in FIG. 3-1.
5. Do not extend exposed vent pipe outside of building more than shown in this document. Condensate could freeze and block vent pipe.

Multiple vent/air terminations

1. When terminating multiple Crest boilers, terminate each vent/air connection as described in this manual (FIG. 3-3).

⚠ WARNING Terminate all vent pipes at the same height and all air pipes at the same height to avoid recirculation of flue products and the possibility of severe personal injury, death, or substantial property damage.

2. Place roof penetrations to obtain minimum clearance of 12 inches (305 mm) between edge of air intake elbow and adjacent vent pipe of another boiler for U.S. installations (see FIG. 3-3). For Canadian installations, provide clearances required by CSA B149.1 Installation Code.
3. The air inlet of a Crest boiler is part of a direct vent connection. It is not classified as a forced air intake with regard to spacing from adjacent boiler vents.

Figure 3-4 Alternate Vertical Terminations with Multiple Boilers

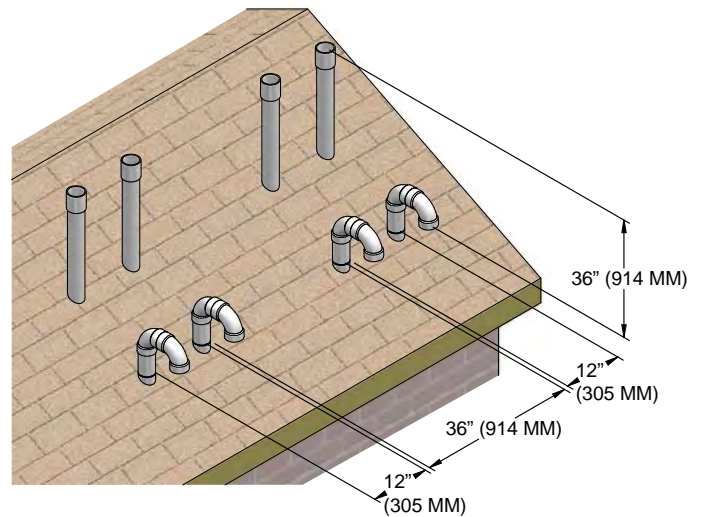
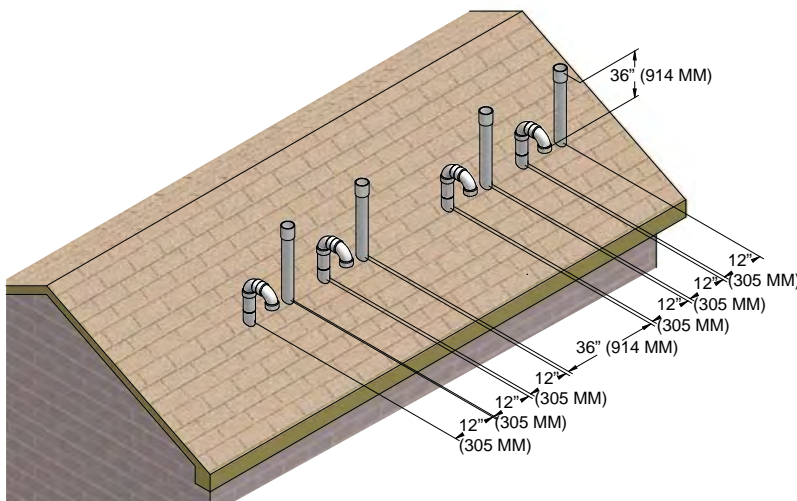

Figure 3-3 Vertical Terminations with Multiple Boilers



4 Sidewall direct venting Vent/air termination – sidewall

WARNING Follow instructions below when determining vent location to avoid possibility of severe personal injury, death, or substantial property damage.

WARNING A gas vent extending through an exterior wall shall not terminate adjacent to a wall or below building extensions such as eaves, parapets, balconies, or decks. Failure to comply could result in severe personal injury, death, or substantial property damage.

WARNING Do not connect any other appliance to the vent pipe or multiple boilers to a common vent pipe except as noted in Section 2 on page 19. Failure to comply could result in severe personal injury, death, or substantial property damage.

CAUTION Sidewall venting commercial products will result in large exhaust plumes in cold climates. Consideration should be taken when locating in proximity to windows, doors, walkways, etc.

NOTICE Installation must comply with local requirements and with the National Fuel Gas Code, NFPA 54 / ANSI Z223.1 for U.S. installations or CSA B149.1 for Canadian installations.

Determine location

Locate the vent/air terminations using the following guidelines:

1. The total length of piping for vent or air must not exceed the limits given in the General Venting Section on page 17 of this manual.
2. You must consider the surroundings when terminating the vent and air:
 - a. Position the vent termination where vapors will not damage nearby shrubs, plants or air conditioning equipment or be objectionable.
 - b. The flue products will form a noticeable plume as they condense in cold air. Avoid areas where the plume could obstruct window views.
 - c. Prevailing winds could cause freezing of condensate and water/ice buildup where flue products impinge on building surfaces or plants.
 - d. Avoid possibility of accidental contact of flue products with people or pets.
 - e. Do not locate the terminations where wind eddies could affect performance or cause recirculation, such as inside building corners, near adjacent buildings or surfaces, window wells, stairwells, alcoves, courtyards, or other recessed areas.

WARNING Sidewall vent and air inlet terminations must terminate in the same pressure zone.

- f. Do not terminate above any door or above or below any window. Condensate can freeze, causing ice formations.
- g. Locate or guard vent to prevent condensate damage to exterior finishes.

Figure 4-1A Sidewall Termination of Air and Vent

NOTICE PVC/CPVC or ABS is acceptable air inlet pipe material.

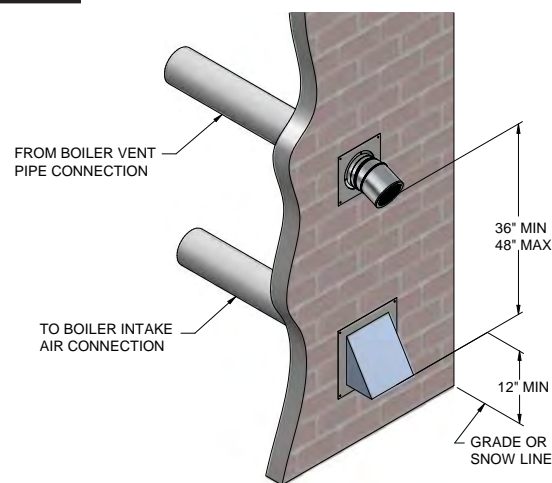

3. Maintain clearances as shown in FIG.'s 4-1A thru 4-4, pages 24 thru 26. The vent termination should not be located in traffic areas such as walkways, adjacent buildings, operable windows, or doors. Also maintain the following:
 - a. Vent must terminate:
 - At least 6 feet (1.8 m) from adjacent walls.
 - Not less than 7 feet (2.1 m) above grade where located adjacent to public walkways.
 - No closer than 12 inches (305 mm) below roof overhang.
 - At least 3 feet (.9 m) above any forced air intake within 10 feet (3 m).
 - No closer than 4 feet (1.2 m) horizontally from any door or window or any other gravity air inlet.
 - b. Air inlet must terminate at least 12 inches (305 mm) above grade or snow line; at least 36 inches (914 mm) below the vent termination.
 - c. Do not terminate closer than 4 feet (1.2 m) horizontally from any electric meter, gas meter, regulator, relief valve, or other equipment. Never terminate above or below any of these within 4 feet (1.2 m) horizontally.
4. Locate terminations so they are not likely to be damaged by foreign objects, such as stones or balls, or subject to buildup of leaves or sediment.

4 Sidewall direct venting

Vent/air termination – sidewall

Figure 4-1B PVC/CPVC/ Polypropylene Sidewall Termination of Air and Vent w/Field Supplied Fittings

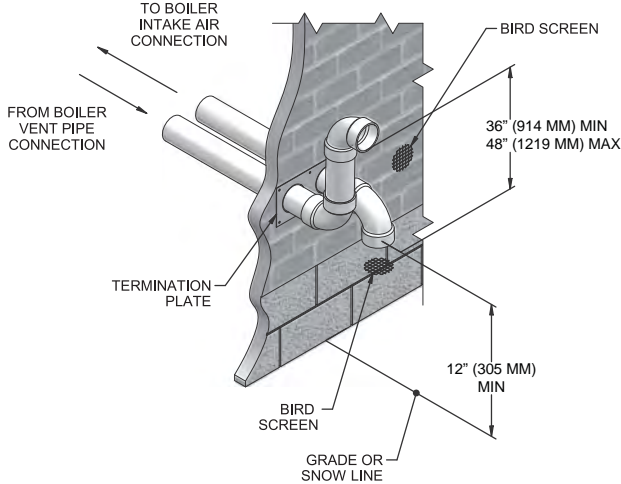

- The air piping must terminate in a down-turned elbow as shown in FIG. 4-1B. This arrangement avoids recirculation of flue products into the combustion air stream.
- The vent piping must terminate in an elbow pointed outward or away from the air inlet, as shown in FIG. 4-1B.

WARNING Do not exceed the maximum lengths of the outside vent piping shown in FIG. 4-1C. Excessive length exposed to the outside could cause freezing of condensate in the vent pipe, resulting in potential boiler shutdown.

Figure 4-1C PVC/CPVC/Polypropylene Sidewall Termination of Air and Vent

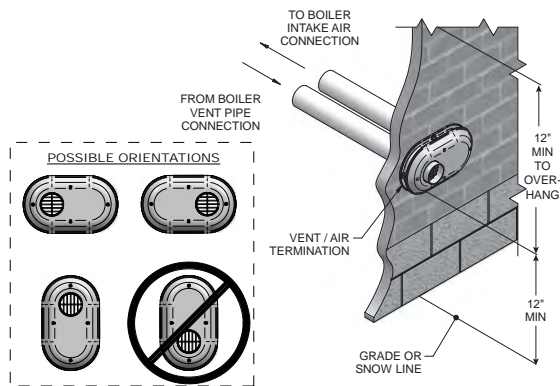

Table 4A Sidewall Vent Kits

Model	Kit #	Air	Vent	Centerline Width
751 - 1001	100157612	6" (152 mm)	6" (152 mm)	7 3/4" (197 mm)

Figure 4-2A PVC/CPVC/ Polypropylene Sidewall Termination w/Field Supplied Fittings

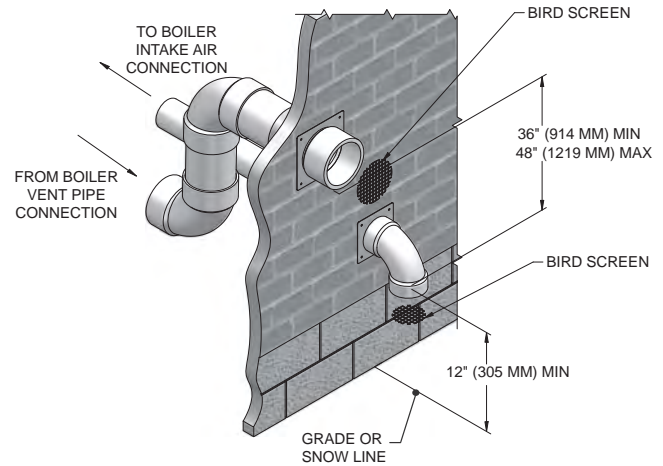
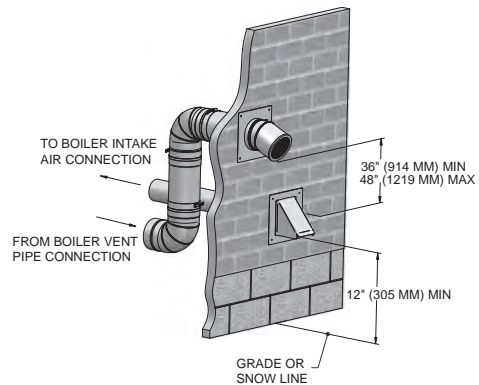

Figure 4-2B Stainless Steel Sidewall Termination w/Field Supplied Fittings



NOTICE PVC/CPVC or ABS is acceptable air inlet pipe material.

- Maintain clearances as shown in FIG.'s 4-1A thru 4-4, pages 24 thru 26. Also maintain the following:
 - Vent must terminate:
 - At least 6 feet (1.8 m) from adjacent walls.
 - No closer than 12 inches (305 mm) below roof overhang.
 - At least 7 feet (2.1 m) above any public walkway.
 - At least 3 feet (.9 m) above any forced air intake within 10 feet (3 m).
 - No closer than 4 feet (1.2 m) below or horizontally from any door or window or any other gravity air inlet.
 - Air inlet must terminate at least 12 inches (305 mm) above grade or snow line; at least 3 feet (.9 m) below the vent termination (FIG. 4-1B); and the vent pipe must not extend more than 24 inches (610 mm) vertically outside the building.
 - Do not terminate closer than 4 feet (1.2 m) horizontally from any electric meter, gas meter, regulator, relief valve, or other equipment. Never terminate above or below any of these within 4 feet (1.2 m) horizontally.

4 Sidewall direct venting *(continued)*

Vent/air termination – sidewall

6. Locate terminations so they are not likely to be damaged by foreign objects, such as stones or balls, or subject to buildup of leaves or sediment.

Figure 4-3 Clearance to Doors and Windows

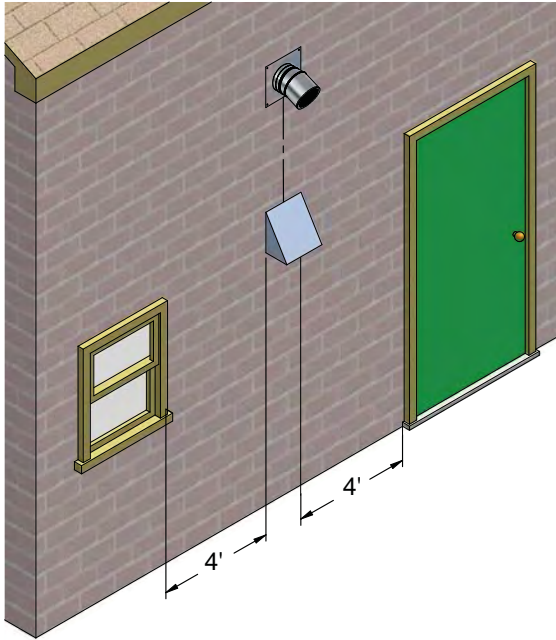
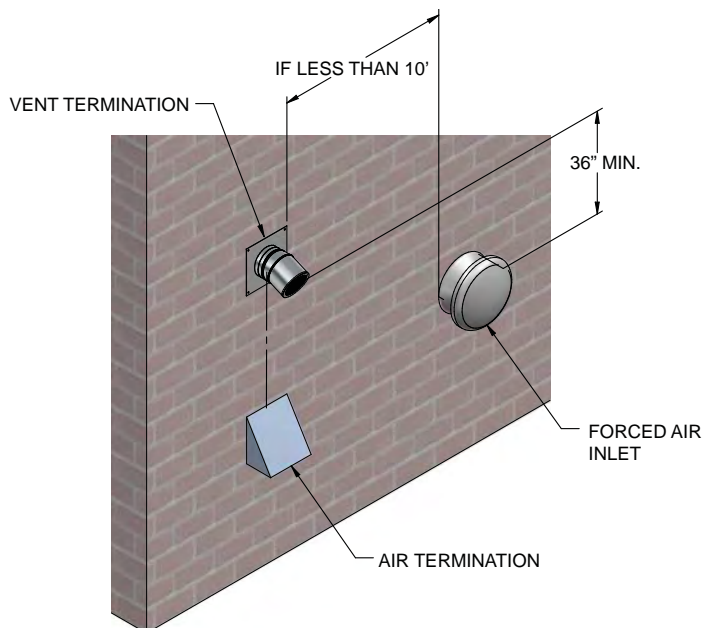

Figure 4-4 Clearance to Forced Air Inlets



CAUTION

Sidewall venting commercial products will result in large exhaust plumes in cold climates. Consideration should be taken when locating in proximity to windows, doors, walkways, etc.

Prepare wall penetrations

1. Air pipe penetration:
 - a. Cut a hole for the air pipe. Size the air pipe hole as close as desired to the air pipe outside diameter.

Vent pipe penetration:

- a. Cut a hole for the vent pipe. For either combustible or noncombustible construction, size the vent pipe hole per the vent manufacturer's instructions.
2. Install the vent and air intake piping. Seal all gaps between the pipes and wall with RTV silicone sealant.
 3. Seal all wall cavities.

Termination and fittings

1. The air termination must be oriented at least 12 inches above grade or snow line as shown in FIG. 4-1A, page 24.
2. Maintain the required dimensions of the finished termination piping as shown in FIG. 4-1A, page 24.
3. Do not extend exposed vent pipe outside of the building more than what is shown in this document. Condensate could freeze and block vent pipe.
4. Stainless steel terminations are designed to penetrate walls with a thickness up to 9.25 inches of standard construction.

Multiple vent/air terminations

1. When terminating multiple Crest boilers terminate each vent/air connection as described in this manual (FIG. 4-5).

WARNING

All vent pipes and air inlets must terminate at the same height to avoid possibility of severe personal injury, death, or substantial property damage.

4 Sidewall direct venting

- Place wall penetrations to obtain minimum clearance of 12 inches (305 mm) between vent pipe and adjacent air inlet, as shown in FIG. 4-5 for U.S. installations. For Canadian installations, provide clearances required by CSA B149.1 Installation Code.
- The air inlet of a Crest is part of a direct vent connection. It is not classified as a forced air intake with regard to spacing from adjacent boiler vents.

Figure 4-5 Multiple Vent Terminations (must also comply with Figure 4-1A)

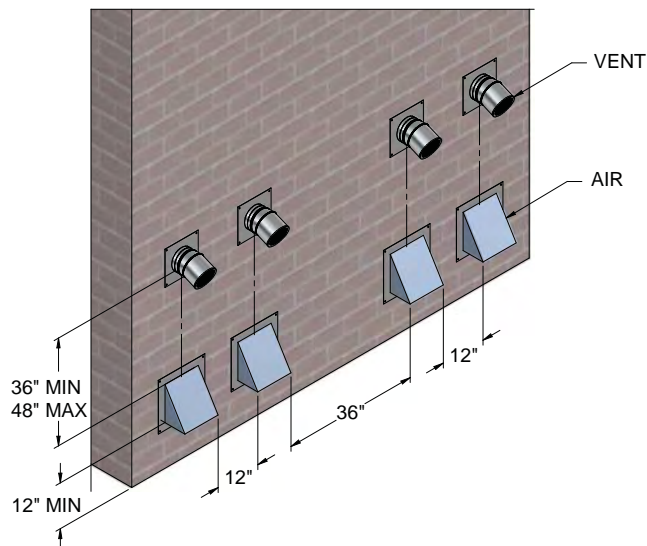

Figure 4-6 Direct Vent Terminations







DIRECT VENT TERMINATIONS			
Air Inlet		Vent Termination	
Dryer Inlet		Straight	
90° Elbow		Mitered	
		23° Elbow	

Figure 4-7 Room Air (Direct Exhaust Terminations)

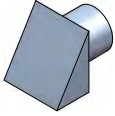
ROOM AIR (DIRECT EXHAUST TERMINATIONS)	
Vent Termination	
23° Elbow	
45° Elbow	
90° Elbow	

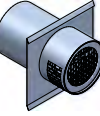
Room air

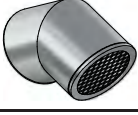
The Crest boiler may be installed with a single pipe carrying the flue products to the outside while using combustion air from the equipment room.

Follow the requirements in the General Venting, Sidewall Direct Venting, and Vertical Direct Venting sections for vent material specifications, vent length requirements, and vent termination requirements.

Install the air inlet cover (shipped loose with the boiler) per FIG. 4-8. Combustion and ventilation air must be supplied to the equipment room per the requirements on pages 12 and 13 of this manual for proper operation of the Crest boiler when utilizing the single pipe method.

Figure 4-8 Room Air Installation

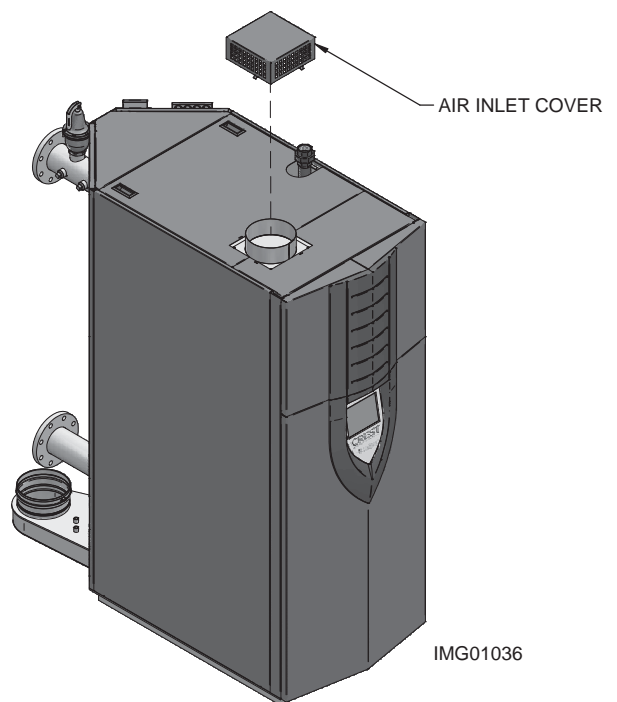

IMG01036

5 Hydronic piping

Circulator sizing

The Crest heat exchanger does have a pressure drop, which must be considered in your system design. Refer to the graph in FIG. 5-1 for pressure drop through the Crest heat exchanger.

Figure 5-1 Pressure Drop vs. Flow

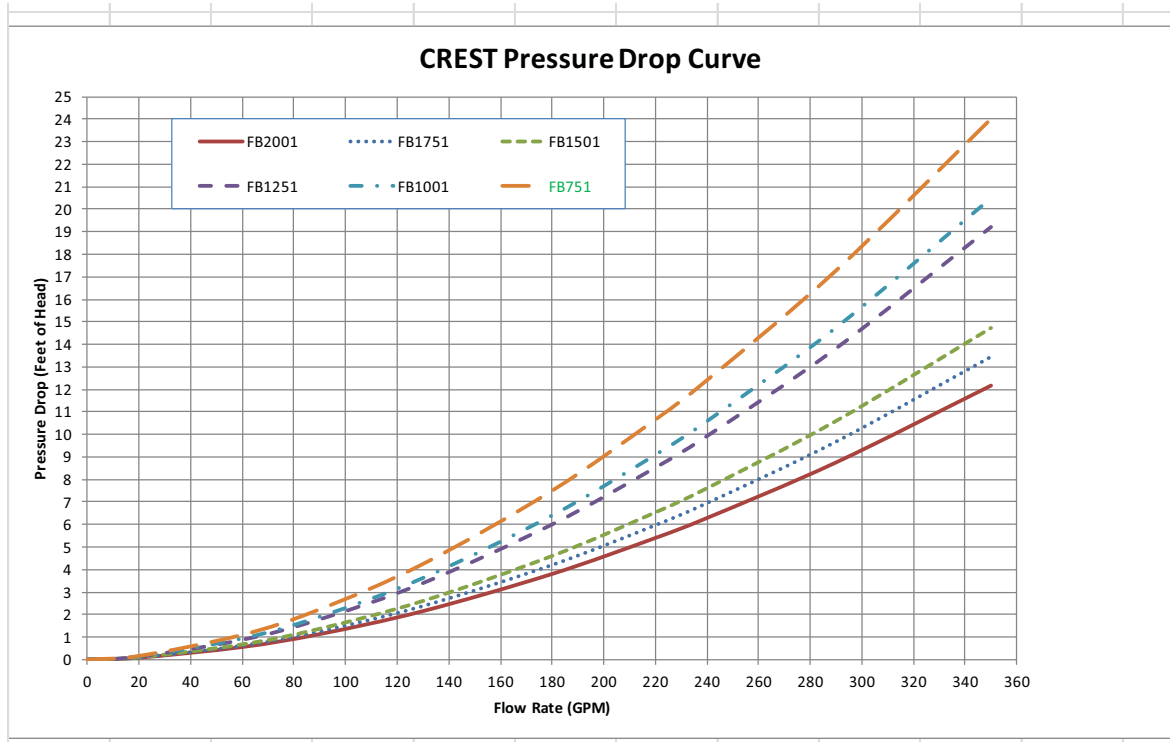

Table 5A Sizing Information for Temperature Rise Applications_20°F, 40°F and 60°F

TEMPERATURE RISE APPLICATIONS							
Model	BOILER CONNECTION SIZE	20°F		40°F		60°F	
		GPM	FT/HD	GPM	FT/HD	GPM	FT/HD
FB 0751	3"	72	1.5	36	0.5	24	0.2
FB 1001	3"	96	2.1	48	0.6	32	0.3
FB 1251	3"	120	3.0	60	0.9	40	0.4
FB 1501	4"	144	3.1	72	0.9	48	0.5
FB 1751	4"	168	3.7	84	1.1	56	0.5
FB 2001	4"	192	4.3	96	1.3	64	0.6

[Crest models are based on 96% AHRI Efficiency]



NOTICE The pressure drop reflected in FIG. 5-1 is for the **boiler only**. Additional allowances must be made for piping, especially if sizing pumps for Primary/Secondary applications.

NOTICE It is required that boiler piping systems utilize *Primary/Secondary or Fixed or Variable Flow Primary* configurations as shown in FIG.'s 5-2 thru 5-5. The use of other boiler piping configurations could result in improper building and system flow rates leading to inadvertent boiler high limit shutdowns and poor system performance.

5 Hydronic piping *(continued)*

Near boiler piping components

- 1. Boiler piping:**
Boiler system piping should be sized per the pipe requirements listed in Tables 5A and 5C.
- 2. Boiler circulating pump:**
Field supplied. When using Primary/Secondary piping the boiler circulating pump should be sized per Table 5A.
- 3. Hot Water Generator circulating pump:**
Field supplied. When installed in a Primary/Secondary arrangement, the Crest requires an additional pump for the Hot Water Generator Loop. The pump should be sized per Table 5A. Consult the indirect water heater operating guide to determine flow characteristics for the selected product used. The pump's total flow and heat requirements are the sum of the boiler and the indirect water heater.
- 4. Boiler isolation valves:**
Field supplied. Full port valves are required. Failure to use full port valves could result in a restricted flow rate through the boiler.
- 5. Check valves:**
Field supplied. Check valves are required for installation as shown in FIG.'s 5-2 and 5-3. Failure to install check valves could result in a reverse flow condition during pump(s) off cycle.
- 6. Domestic indirect hot water isolation valves:**
Field supplied. Full port valves are required. Failure to use full port valves could result in a restricted flow rate through the boiler.
- 7. Anti-scald mixing valve:**
Field supplied. An anti-scald mixing valve is recommended when storing domestic hot water above 115°F (46°C).
- 8. Pressure relief valve:**
Factory supplied. The pressure relief valve is sized to ASME specifications.
- 9. System temperature sensor:**
Lochinvar supplies a system temperature sensor. The sensor is to be installed in the heating loop downstream from the boiler hot water piping and heating loop junction. The sensor should be located far enough downstream to sense system diluted water temperature.
- 10. Water Meter:**
Field supplied. A water meter to monitor makeup water is recommended. Makeup water volume should not exceed 5% of total system per year.

NOTICE

A system supply sensor (factory supplied) **MUST BE** installed with Primary/Secondary systems for proper boiler operation.

11. Y-Strainer:

Field supplied. Install a Y-strainer or equivalent multi-purpose strainer just before the boiler pump at the inlet of the heat exchanger. This item is used to remove system debris from older hydronic systems and to protect newer systems.

CAUTION

The maximum allowable water flow rate through a single Crest boiler is 350 GPM. Exceeding this flow rate will result in damage to the heat exchanger and/or piping.

NOTICE

Reference Table 5B1 for the minimum recommended flow rate through a single Crest boiler at full fire to maintain a 80°F temperature rise. Reference Table 5B2 for the absolute minimum flow rate through a single Crest boiler.

Table 5B1 Minimum Flow Rate with the Boiler at Full Fire



TEMPERATURE RISE APPLICATIONS	
MODEL	FLOW RATE (GPM)
FB(N,L)0751	18
FB(N,L)1001	24
FB(N,L)1251	30
FB(N,L)1501	36
FB(N,L)1751	42
 FB(N,L)2001	48
[Based on 80°F Temperature Rise]	

Table 5B2 Absolute Minimum Flow Rate

ABSOLUTE MINIMUM FLOW RATE	
MODEL	FLOW RATE (GPM)
FB(N,L)0751	18
FB(N,L)1001	18
FB(N,L)1251	18
FB(N,L)1501	25
FB(N,L)1751	25
 FB(N,L)2001	25

5 Hydronic piping *(continued)*

Table 5C Multiple Boilers - Common Header - Primary / Secondary Flow

Model	Number of Units						
	2	3	4	5	6	7	8
Recommended Common Header Pipe Sizes in Inches							
FB 0751	4	4	5	5	6	6	7
FB 1001	4	5	5	6	7	7	8
FB 1251	5	5	6	7	7	8	10
FB 1501	5	6	7	7	8	10	10
FB 1751	5	6	7	8	10	10	10
FB 2001	6	6	8	8	10	10	12

[Based on a boiler ΔT of 30°F.]



NOTICE A system supply sensor (factory supplied) **MUST BE** installed for proper boiler operation.

Figure 5-3 Multiple Boilers - Common Header - Recommended - Primary / Secondary Flow

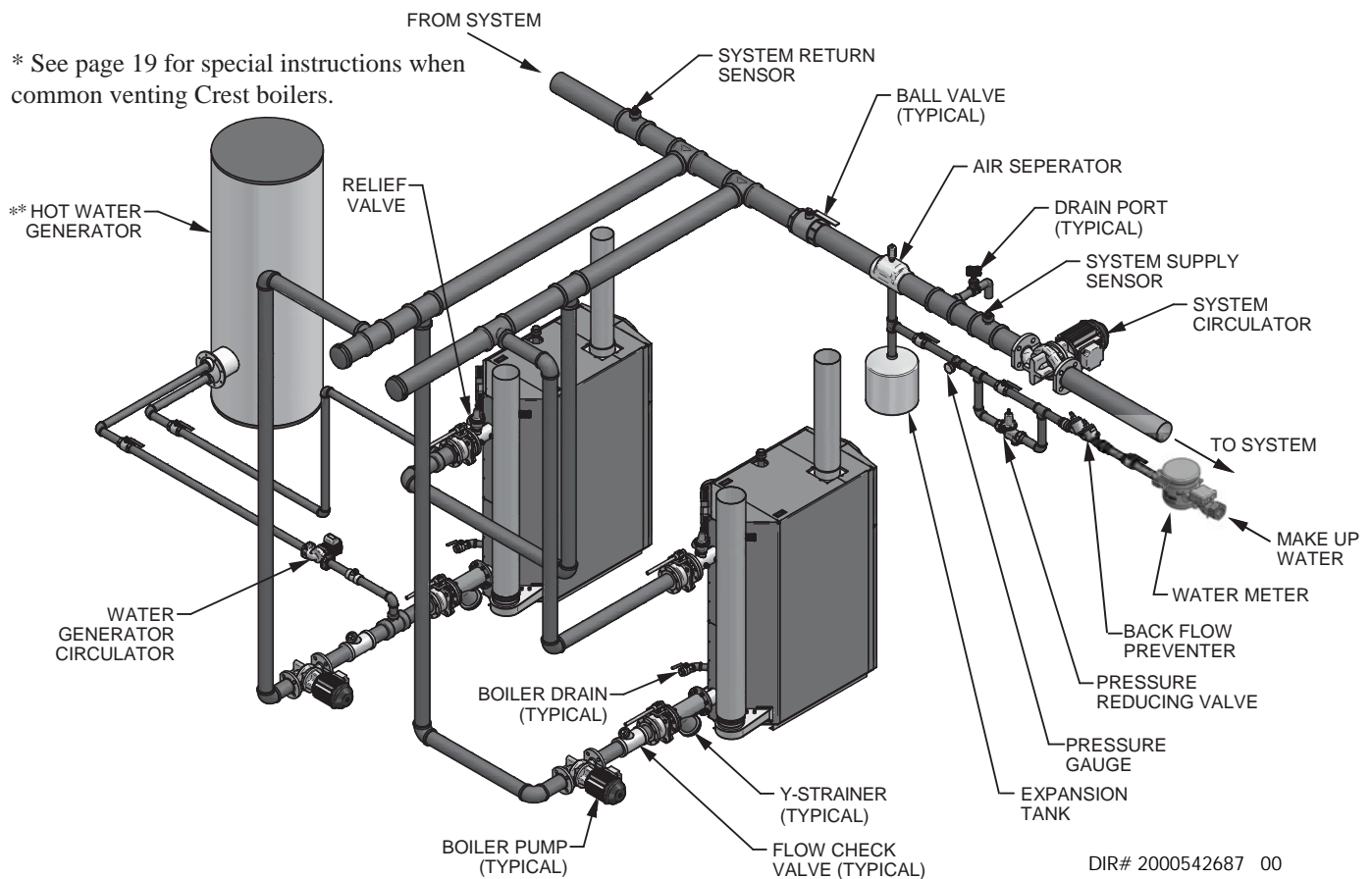

NOTICE System flow should always remain higher than the required flow for the boiler(s) when the boiler(s) is in operation to prevent short cycling and high limit issues.

NOTICE Please note that these illustrations are meant to show piping concepts only, the installer is responsible for all equipment. The installer must follow all manufacturer's installation instructions for each system component. The installer is responsible for compliance with local codes.

TOP VIEW

VENT - FOR UNITS WITH AMBIENT ABOVE 105° F

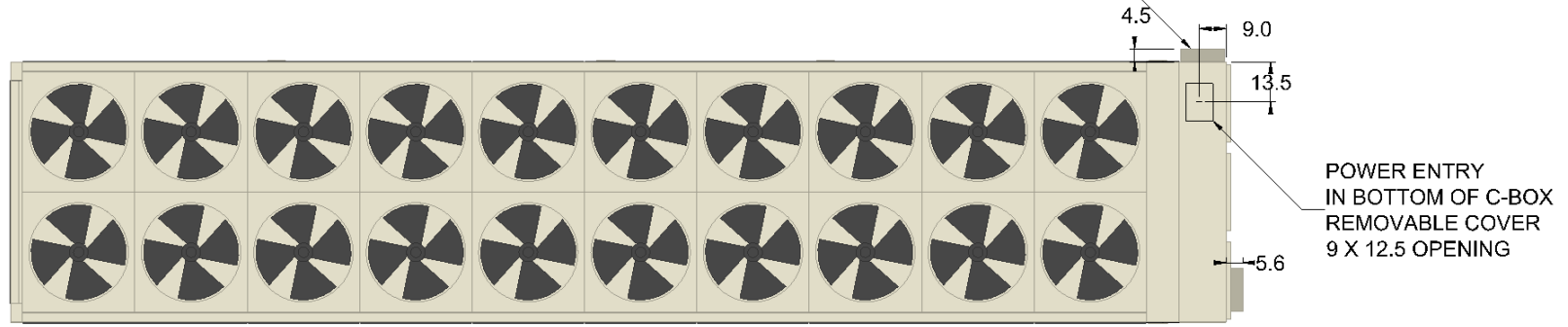

LEFT VIEW

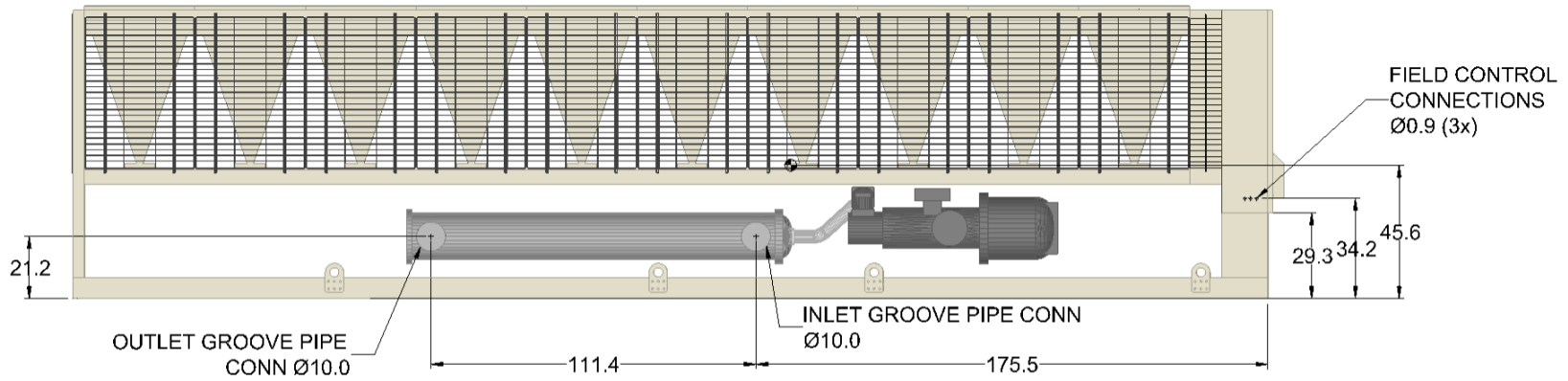

Product Drawing

Product:

Model: AWV020A

Unit Tag: 300 Ton Air Cooled Screw

Project Name: ATC Sanctuary Littleton

June 08, 2017

Ver/Rev:

Sheet: 1 of 1

Sales Office: HTS New England (Boston)

Sales Engineer:

Scale: NTS

Tolerance: +/- 0.25"

Dwg Units: (in)



13600 Industrial Park Blvd. Minneapolis, MN 55441
www.DaikinApplied.com Software Version: 07.50

No change to this drawing may be made unless approved in writing by Daikin Applied. Purchaser must determine that the equipment is fit and sufficient for the job specifications.

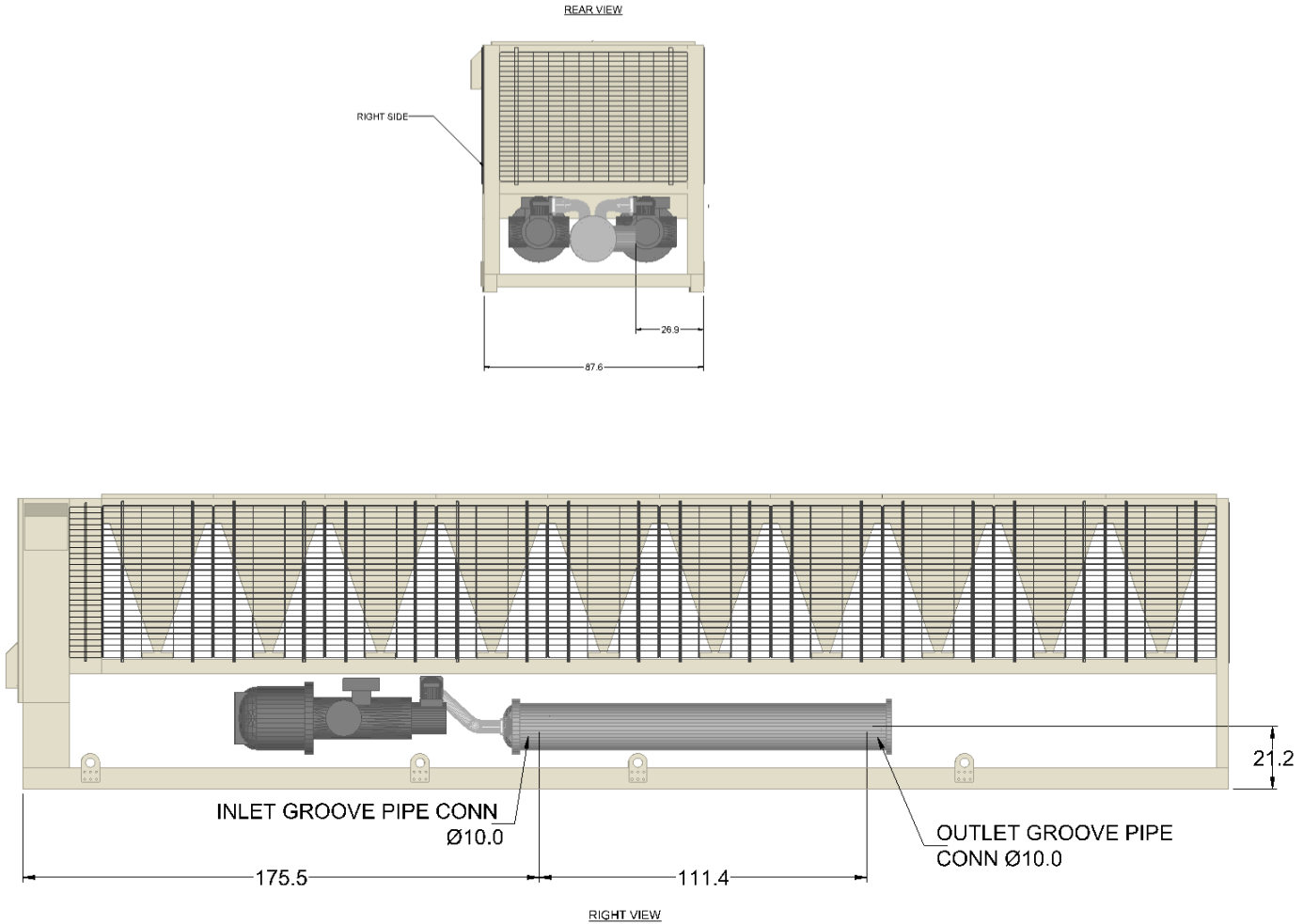

Product Drawing	Unit Tag: 300 Ton Air Cooled Screw			Sales Office: HTS New England (Boston)			 13600 Industrial Park Blvd. Minneapolis, MN 55441 www.DaikinApplied.com Software Version: 07.50
Product:	Project Name: ATC Sanctuary Littleton			Sales Engineer:			
Model: AWW020A	June 08, 2017	Ver/Rev:	Sheet: 1 of 1	Scale: NTS	Tolerance: +/- 0.25"	Dwg Units: (in)	
No change to this drawing may be made unless approved in writing by Daikin Applied. Purchaser must determine that the equipment is fit and sufficient for the job specifications.							

Mounting and Lifting

BASE FRAME TOP VIEW

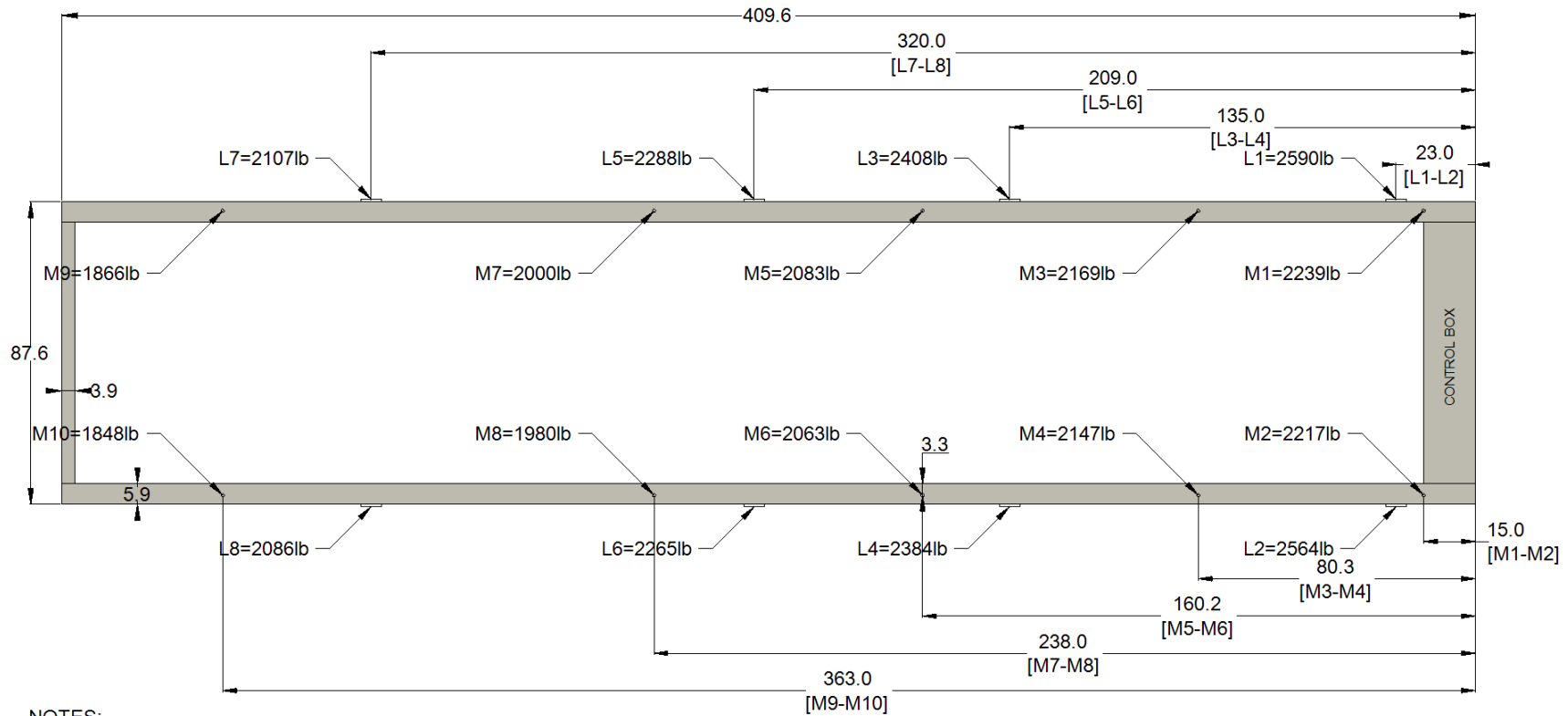

NOTES:

- 1) L = LIFTING WEIGHT
- 2) M = MOUNTING LOAD
- 3) UNIT SHIPPING WEIGHT = 18692lb
- 4) UNIT OPERATING WEIGHT = 20612lb

Product Drawing	Unit Tag: 300 Ton Air Cooled Screw	Sales Office: HTS New England (Boston)	 13600 Industrial Park Blvd. Minneapolis, MN 55441 www.DaikinApplied.com Software Version: 07.50
Product:	Project Name: ATC Sanctuary Littleton	Sales Engineer:	
Model: AWV020A	June 08, 2017	Ver/Rev: Sheet: 1 of 1	

No change to this drawing may be made unless approved in writing by Daikin Applied. Purchaser must determine that the equipment is fit and sufficient for the job specifications.

Document Summary Page

BLW Engineers, Inc.

311 Great Road, Post Office Box 1551, Littleton, Massachusetts 01460 t 978.486.4301 f 978.428.0067 email: Info@blwengineers.com

Shop Drawing Review Form

PROJECT: Sanctuary Medicinals Inc.
234 Taylor Street
Littleton, MA

JOB NO:

SPEC. SECTION: 15500
Mechanical

SPEC. PAR. NO: Boilers

SUBMITTAL NO: 001

X	APPROVED		DISAPPROVED
	APPROVED AS NOTED <i>Resubmission not required</i>		NOTED <i>No Action Required</i>
	REVISE AND RESUBMIT		
<p>Approval is only for conformance with the design concept of the project and Compliance with the information given in the Contract Documents. Contractor is responsible for all dimensions, quantities and performance requirements to be confirmed and correlated at the job site; for all information that pertains solely to the fabrication processes or to techniques of construction; for all coordination of the work of all trades; and for assuring consistency with the Contract Documents. Approval of drawings or items does not relieve the Contractor of the responsibility for complying with all requirements of the Contract Documents.</p> <p style="text-align: right;">BLW Engineers, Inc.</p> <p style="text-align: right;">Date: October 31, 2017 <i>Erik M Gath</i></p> <p style="text-align: right;">Mechanical – Erik M Gath</p>			

Boilers	Approved
----------------	-----------------

CREST COMMERCIAL CONDENSING BOILER

JOB NAME Sanctuary Medicinals
LOCATION Littleton, MA
ENGINEER BLW Engineers
WHOLESALE FW Webb
CONTRACTOR _____
MODEL NO. FBN2001
TYPE GAS Natural Gas
EQUIPMENT TAG B-1-2

NOTES Providing Qty (2) Lochinvar FBN2001 boiler(s) with Condensate Neutralization Kits, BACnet MS/TP BMS Communications, 50 PSI Relief Valves (75, 100, 125, 150 PSI available upon request)

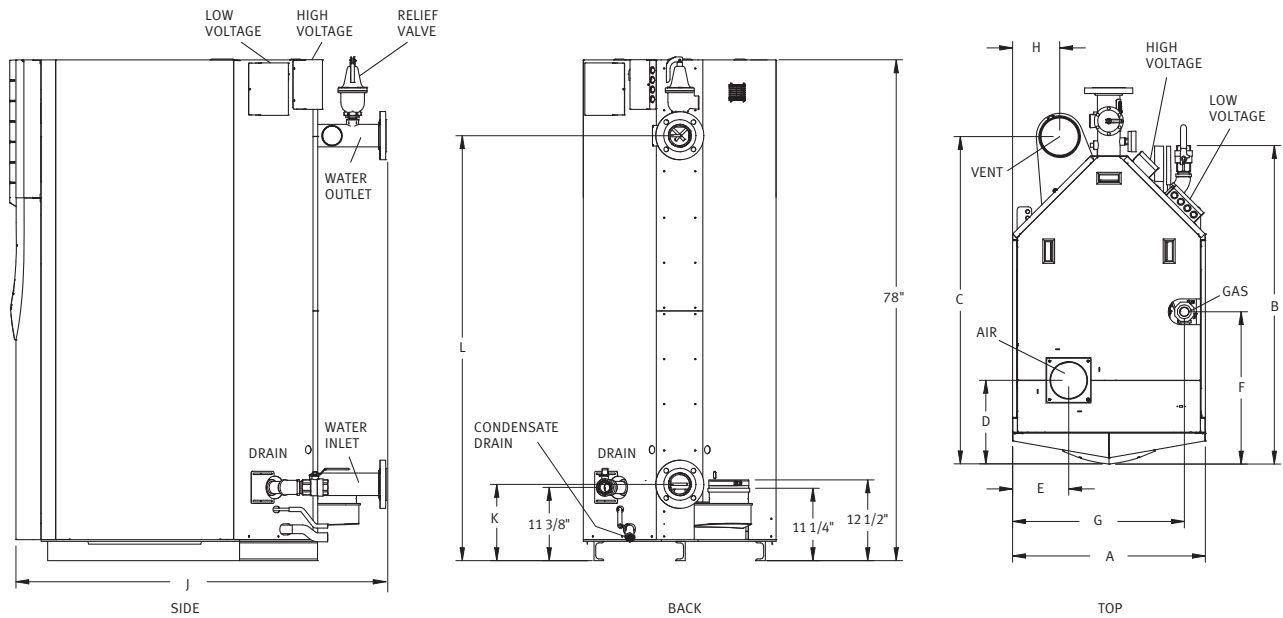

Model Number	Input MBH		AHRI Thermal %	Output MBH	Net AHRI Rating MBH	Turndown	A	B	C	D	E	F	G	H	J	K	L	Water			Oper. Weight	Ship. Weight	
	Min	Max																Gas Conn.	Inlet	Air Intake			Vent Size
<input type="checkbox"/> FB*0751	50	750	96.2%	722	627	15:1	30"	49-1/2"	51"	13"	8-3/4"	23-3/4"	26-3/4"	7-3/8"	57-5/8"	11-7/8"	66-1/8"	1-1/4"	3"	6"	6"	1,768	1,560
<input type="checkbox"/> FB*1001	50	1,000	96.2%	962	837	20:1	30"	49-1/2"	51"	13"	8-3/4"	23-1/8"	26-3/4"	6-1/2"	57-5/8"	11-7/8"	66-1/8"	1-1/4"	3"	6"	6"	1,838	1,596
<input type="checkbox"/> FB*1251	63	1,250	96.2%	1,203	1,046	20:1	30"	49-1/2"	51-3/8"	13"	8-3/4"	21-5/8"	26-3/4"	6-1/2"	57-3/4"	11-7/8"	66-1/8"	1-1/4"	3"	6"	8"	1,975	1,648
<input type="checkbox"/> FB*1501	60	1,500	96.2%	1,443	1,255	25:1	30"	59-1/4"	62-3/8"	15-7/8"	9"	27-7/8"	26-7/8"	5-1/8"	68"	12-3/8"	65-3/8"	1-1/2"	4"	8"	8"	2,307	1,961
<input type="checkbox"/> FB*1751	70	1,750	96.2%	1,684	1,464	25:1	30"	58-3/4"	61-1/2"	15-7/8"	9"	27-1/8"	27"	5-1/8"	68"	12-3/8"	65-3/8"	1-1/2"	4"	8"	8"	2,458	2,017
<input checked="" type="checkbox"/> FB*2001	80	1,999	96.2%	1,924	1,673	25:1	30"	58-3/4"	61-1/2"	15-7/8"	9"	26-3/4"	27"	5-1/8"	68"	12-3/8"	65-3/8"	1-1/2"	4"	8"	8"	2,570	2,087

Note: *Insert "N" for natural gas, "L" for LP gas models and "D" for dual fuel. Indoor installation only. *Information subject to change without notice

CREST[®]

CONDENSING BOILER

CODES & REGISTRATIONS

ANSI Z21.13/CSA Certified
ASME Certified, "H" Stamp / National Board
California Code Compliant
CSD1 / Factory Mutual / GE Gap Compliant
AHRI Certified



SMART TOUCH[™] FEATURES

CON-X-US[®] Remote Connect

SMART TOUCH Touchscreen Operating Control

Full-Color 8" Touchscreen LCD Display

Built-in Cascading Sequencer for up to 8 Boilers with Built-in Redundancy

- Cascade Multiple Sized Boilers
- Lead/Lag Cascade
- Efficiency Optimized Cascade

Front-End Loading Capability with Copper-Fin II[®] and Power-Fin[®] Boilers

Building Management System Integration with 0-10 VDC Input

BACnet MSTP Communications

Modbus Communications

Outdoor Reset Control with Outdoor Air Sensor

Password Security

Domestic Hot Water Prioritization

- DHW tank piped with priority in the boiler loop
- DHW tank piped as a zone in the system with the pumps controlled by the Smart System
- DHW Modulation Limiting
- Separately Adjustable SH/DHW Switching Times

Low Water Flow Safety Control & Indication

Inlet & Outlet Temperature Readout

Freeze Protection

Service Reminder

Time Clock

Data Logging

- Hours Running, Space Heating
- Hours Running, Domestic Hot Water
- Hours Running, Modulation Rate
- Ignition Attempts
- Last 10 Lockouts

Programmable System Efficiency Optimizers

- Night Setback
- Anti-Cycling
- Outdoor Air Reset Curve
- Ramp Delay
- Boost Temperature & Time
- Modulation Factor Control

Three Pump Control

- System Pump
- Boiler Pump
- Domestic Hot Water Pump

High-Voltage Terminal Strip

- 120 VAC / 60 Hertz / 1 Phase Power Supply
- System Pump, Boiler Pump and DHW Pump

Power

Low-Voltage Terminal Strip

- 24 VAC Auxiliary Device Relay
- Auxiliary Proving Switch Contacts
- Alarm on Any Failure Contacts
- Runtime Contacts
- DHW Thermostat Contacts
- Unit Enable/Disable Contacts
- System Sensor Contacts
- DHW Tank Sensor Contacts
- Outdoor Air Sensor Contacts
- Cascade Contacts
- 0-10 VDC BMS External Control Contact
- 0-10 VDC Variable Speed Boiler Pump Control

Contact

STANDARD FEATURES

96.2% Thermal Efficiency (AHRI)
Up to 99% Thermal Efficiency in Low-Temp. Applications
Modulating Burner with up to 25:1 Turndown
Direct-Spark Ignition
Low-NOx Operation
Sealed Combustion
Air Inlet Filter w/Replacement Reminder
Low Gas Pressure Operation
Vertical and Horizontal Direct Venting
> Direct Vent up to 100 Feet
> PVC, CPVC, Polypropylene or AL29-4C
ASME "H" Stamped Heat Exchanger
316L Stainless Steel Fire Tubes
160 psi Working Pressure
On/Off Switch
Adjustable High Limit with Manual Reset
Low Water Cutoff with Manual Reset & Test
High & Low Gas Pressure Switches w/Manual Reset
Low Air Pressure Switches

Condensate Trap w/Blocked Drain Switch
Drain Valve

System Sensor

Outdoor Air Sensor

Inlet & Outlet Temperature Sensors

High-Voltage Terminal Strip

Low-Voltage Terminal Strip

Downstream Gas Test Cocks

50 psi ASME Relief Valve

Temperature & Pressure Gauge

Zero Clearances to Combustible Materials

10-Year Limited Warranty (See Warranty for Details)

1-Year Warranty on Parts (See Warranty for Details)

OPTIONAL EQUIPMENT

- Wireless Outdoor Temperature Sensor
- Alarm Bell
- BMS Gateway - BACnet IP or LonWorks
- Condensate Neutralization Kit
- SMART TOUCH PC Software
- Common Vent Kits
- Dual Fuel Gas Train
- 75 psi ASME Relief Valve
- 100 psi ASME Relief Valve
- 125 psi ASME Relief Valve
- 150 psi ASME Relief Valve
- Motorized Isolation Valve
- Variable Speed Boiler Pump

Electrical Options (Shipped Loose):

- 208V/3Ø/60Hz
- 480V/3Ø/60Hz
- 600V/3Ø/60Hz

VENTING OPTIONS

- Direct Vent Vertical
- Direct Vent Horizontal
- Vertical Vent with Sidewall Air Intake
- Sidewall Vent with Rooftop Air Intake
- Vertical Vent with Optional Room Air
- Sidewall Vent with Optional Room Air
- Common Vent



Lochinvar, LLC
300 Maddox Simpson Parkway
Lebanon, Tennessee 37090
P: 615.889.8900 | F: 615.547.1000
Lochinvar.com





CREST BOILER PRODUCT SUMMARY

(FB) 750,000 - 2,000,000 BTU/HR

	FB-0751	FB-1001	FB-1251	FB-1501	FB-1751	FB-2001
WATER						
GALLON CAPACITY	73	77	87	94	106	111
HEATING SURFACE (SQ. FT.)	80	97	132	153	176	187
INLET WATER CONNECTION	3" Flanged	3" Flanged	3" Flanged	4" Flanged	4" Flanged	4" Flanged
OUTLET WATER CONNECTION	3" Flanged	3" Flanged	3" Flanged	4" Flanged	4" Flanged	4" Flanged
DRAIN	1-1/2"	1-1/2"	1-1/2"	1-1/2"	1-1/2"	1-1/2"
MAXIMUM FLOW RATE	350	350	350	350	350	350
MINIMUM FLOW RATE	18	18	18	25	25	25
20°F ΔT WATER FLOW (GPM)	72	96	120	144	168	192
HEAD LOSS (FT. OF HD.)	1.5	2.1	3.0	3.1	3.7	4.3
40°F ΔT WATER FLOW (GPM)	36	48	60	72	84	96
HEAD LOSS (FT. OF HD.)	0.5	0.6	0.9	0.9	1.1	1.3
MAX. WORKING PRESSURE (PSI)	160	160	160	160	160	160
# OF RELIEF VALVES	1	1	1	1	1	1
RELIEF VALVE SIZE	1"	1"	1"	1"	1"	1 1/4"
RELIEF VALVE RATING (MBH)	1,954,000	1,954,000	1,954,000	1,954,000	1,954,000	3,075,000
RELIEF VALVE PRESSURE RATING (PSI)	50	50	50	50	50	50
GAS						
BTU/HR INPUT	750,000	1,000,000	1,250,000	1,500,000	1,750,000	2,000,000
BTU/HR OUTPUT (HIGH FIRE)	720,000	960,000	1,200,000	1,440,000	1,680,000	1,920,000
BTU/HR OUTPUT (LOW FIRE)	48,100	48,100	60,125	57,720	67,340	76,960
INLET CONNECTION	1 1/4"	1 1/4"	1 1/4"	1 1/2"	1 1/2"	1 1/2"
MAX. INLET PRESSURE, NAT	14" w.c.	14" w.c.	14" w.c.	14" w.c.	14" w.c.	14" w.c.
MIN. INLET PRESSURE, NAT	4" w.c.	4" w.c.	4" w.c.	4" w.c.	4" w.c.	4" w.c.
MAX. INLET PRESSURE, LP	14" w.c.	14" w.c.	14" w.c.	14" w.c.	14" w.c.	14" w.c.
MIN. INLET PRESSURE, LP	4" w.c.	4" w.c.	4" w.c.	4" w.c.	4" w.c.	4" w.c.
ELECTRICAL *						
VOLTAGE/HEATER (VAC)	120/1PH	120/1PH	120/1PH	120/1PH	120/1PH	120/1PH
VOLTAGE/CONTROL (VAC)	24	24	24	24	24	24
TOTAL AMPS	5	6	7	10	10	13
# OF ELECTRICAL CONNECTIONS	1	1	1	1	1	1
DIMENSIONS						
HEIGHT	78"	78"	78"	78"	78"	78"
WIDTH	30"	30"	30"	30"	30"	30"
DEPTH	54"	54"	54"	66"	66"	66"
SHIPPING WEIGHT (lbs.)	1,560	1,596	1,648	1,961	2,017	2,087
OPERATING WEIGHT (lbs.)	1,768	1,838	1,975	2,307	2,458	2,570
SERVICE CLEARANCES (RECOMMENDED)						
FRONT	30"	30"	30"	30"	30"	30"
REAR	24"	24"	24"	24"	24"	24"
RIGHT SIDE	24"	24"	24"	24"	24"	24"
LEFT SIDE	24"	24"	24"	24"	24"	24"
TOP	24"	24"	24"	24"	24"	24"
DIRECT VENTING						
VENT SIZE	6"	6"	8"	8"	8"	8"
AIR INLET SIZE	6"	6"	6"	8"	8"	8"
VENT CATEGORY	II or IV	II or IV	II or IV	II or IV	II or IV	II or IV
VENT MATERIAL	SS, CPVC, PVC, Polypro	SS, CPVC, PVC, Polypro	SS, CPVC, PVC, Polypro	SS, CPVC, PVC, Polypro	SS, CPVC, PVC, Polypro	SS, CPVC, PVC, Polypro

* Electrical - For alternate voltages and amp draws, please consult the factory or the installation and operation manual.

Boiler Efficiency Curve

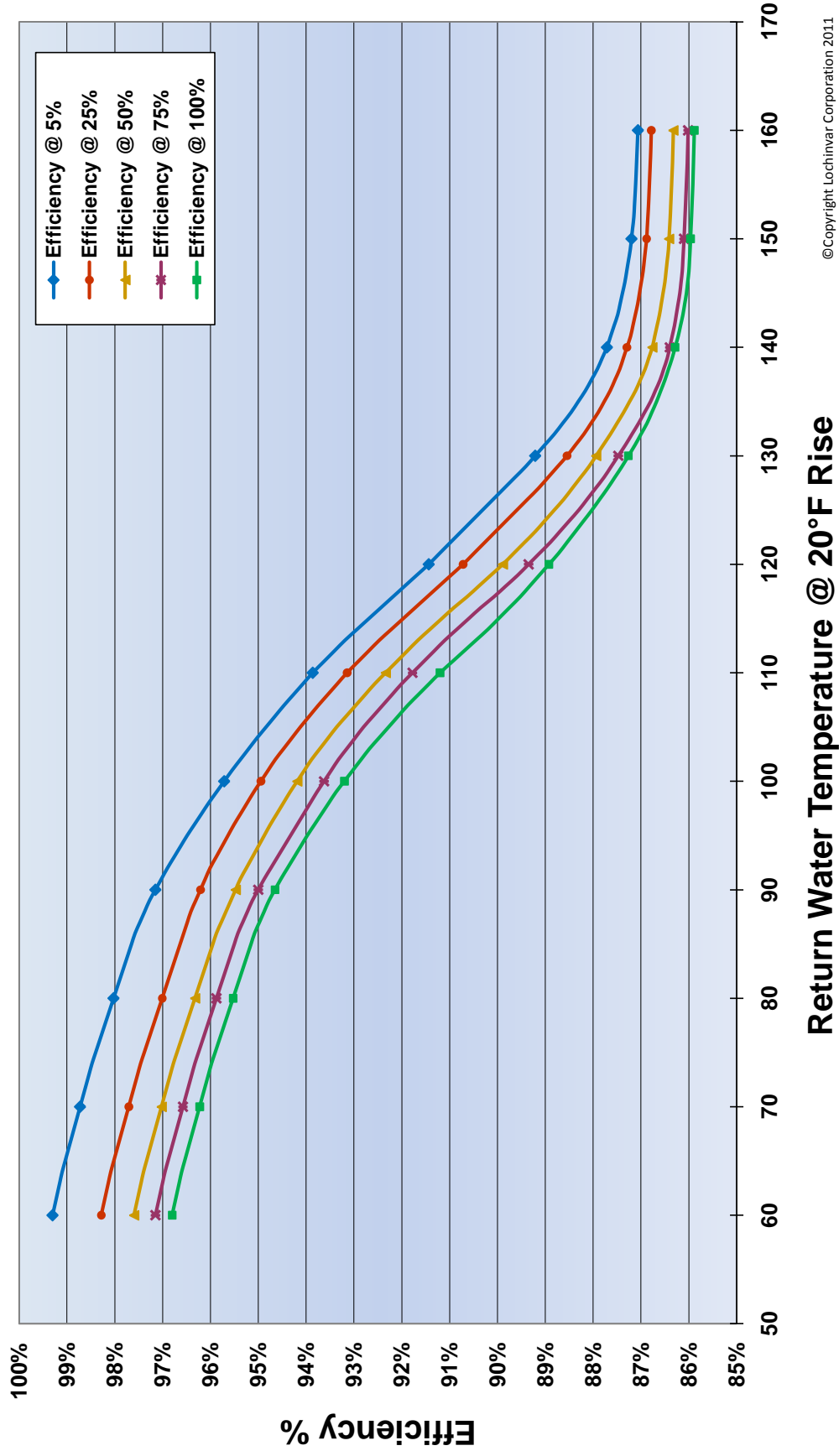

2 General venting

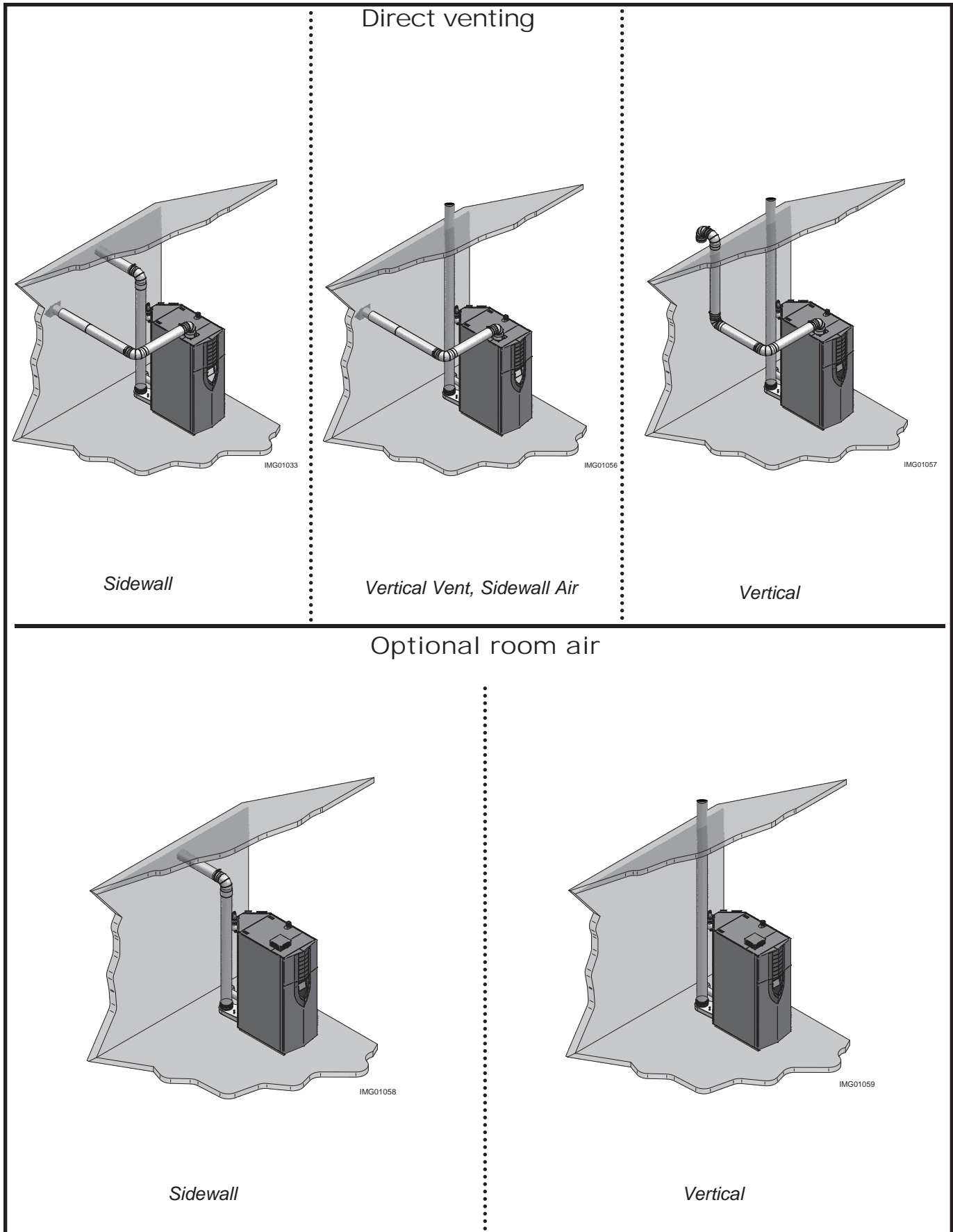



June 20, 2017

Subject: Buy American Act – 41 U.S.C. § 10a-10d

To whom it may concern:

Please be advised. Lochinvar Corporation is a U.S. Manufacturer located in Lebanon, Tenn. Lochinvar adheres to the guidelines set forth in Federal Acquisition Regulation – FAR 52.225.11 and confirms that Lochinvar water heaters, pool heaters, boilers and storage tanks meet the requirements of the *Buy American Act*.

Michael G. Juhnke
Product Program Manager, M.E.
Lochinvar, LLC

Division of Professional Licensure

Mass.Gov

[Mass.Gov Home](#) [State Agencies](#) [A-Z Topics](#)

[Home](#) › [Division of Professional Licensure](#) › [Board of Registration of Plumbers and Gas Fitters](#) ›

Accepted Plumbing Products Online System

By the [Division of Professional Licensure](#)

ONLINE SERVICES

- [Check a License](#)
- [Locate a Licensed Professional](#)
- [Online Address Change](#)
- [Contact the Agency](#)

[More...](#)

Table. ONLINE PLUMBING PRODUCTS SYSTEM: SEARCH RESULTS

Search Criteria:

Type: **Gas**
 Manufacturer: **Lochinvar LLC**
 Product:
 Model: **FB(**
 Description:
[New Search](#)

There are **8** record(s) in our database fitting your search criteria. Please note that if your product is not displayed in the search results, you can refine your search criteria.

Displaying page **1** of **1** search results pages
 Requested products per page: **50**.

PRODUCT, DESCRIPTION, APPROVAL CONDITION	MANUFACTURER	MODEL	ACCEPTED	EXPIRES	APPROVAL CODE
Crest Gas Fired Hot Water Boiler	Lochinvar LLC	FB(N, L)0751	2/4/2015	2/4/2018	G1-0215-330
Crest Gas Fired Hot Water Boiler	Lochinvar LLC	FB(N, L)1001	2/4/2015	2/4/2018	G1-0215-330
Crest Gas Fired Hot Water Boiler	Lochinvar LLC	FB(N, L)1251	2/4/2015	2/4/2018	G1-0215-330
Crest Gas Fired Hot Water Boiler	Lochinvar LLC	FB(N, L)1501	2/4/2015	2/4/2018	G1-0215-330
Crest Gas Fired Hot Water Boiler	Lochinvar LLC	FB(N, L)1751	2/4/2015	2/4/2018	G1-0215-330
Crest Gas Fired Hot Water Boiler	Lochinvar LLC	FB(N, L)2001	2/4/2015	2/4/2018	G1-0215-330
Crest Gas Fired Hot Water Boiler	Lochinvar LLC	FB(N, L)4000	10/3/2012	8/7/2016	G3-0813-76
Crest Gas Fired Hot Water Boiler	Lochinvar LLC	FB(N, L)5000	10/3/2012	8/7/2016	G3-0813-76

[First Page](#) | [Previous Page](#) | [Next Page](#) | [Last Page](#)



Support Request and Report Form

The Request portion of this form (pages 1&2) must be completed by the contractor.

Please return completed form to Shelly Tetreault (stetreault@fiainc.com or via fax 781-933-3965)

We will confirm back to finalize startup date

Job Name

Address	City	State	Zip

FIA Salesperson	Contractor		
Contractor PM	Contractor PM Phone	Contractor PM Email	
Job Site Contact	Contact Phone	Contact Email	
Alternate Contact	Alternate Contact Phone	Alternate Contact Email	
Expected Date Unit(s) to be ready for Startup		Jobsite Hours	

Unit 1	Manufacturer	Model Number	Serial Number

Unit 2	Manufacturer	Model Number	Serial Number

Unit 3	Manufacturer	Model Number	Serial Number

Unit 4	Manufacturer	Model Number	Serial Number

NOTE: If equipment is operated with any of the safety and or warranty discrepancies listed in the Notes Section, the customer could be responsible for any and all safety issues and/or non-warranty damage to the equipment caused by equipment operation.

Customer _____



Types of Support Requested:

- Start UP
 Warranty
 Owner Training
 Pre-Natal
 Other Describe: _____

Pre-StartUp Checklist

	Yes	No	N/A
Proper piping according to Enginner/Manufacturer Specifications	<input type="checkbox"/>	<input type="checkbox"/>	<input type="checkbox"/>
Properly sized gas supply line?	<input type="checkbox"/>	<input type="checkbox"/>	<input type="checkbox"/>
Adequate gas Supply (upstream 4-14") pressure to the unit?	<input type="checkbox"/>	<input type="checkbox"/>	<input type="checkbox"/>
All gas supply lines purged of air per NFPA 54?	<input type="checkbox"/>	<input type="checkbox"/>	<input type="checkbox"/>
Is the piping installed and water on the system and purged of air?	<input type="checkbox"/>	<input type="checkbox"/>	<input type="checkbox"/>
Proper venting of the system to the atmosphere per manufacturers specifications and National Fuel Gas Code?	<input type="checkbox"/>	<input type="checkbox"/>	<input type="checkbox"/>
Proper voltage supply to the system- All connections are made and comply to all local codes?	<input type="checkbox"/>	<input type="checkbox"/>	<input type="checkbox"/>
Is a BMS controlling the operation of the equipment?	<input type="checkbox"/>	<input type="checkbox"/>	<input type="checkbox"/>
If Yes what protocol? _____			
Is there a hardwire enable?	<input type="checkbox"/>	<input type="checkbox"/>	<input type="checkbox"/>
Is there a 0-10V Signal?	<input type="checkbox"/>	<input type="checkbox"/>	<input type="checkbox"/>
Have the Service Clearences of the manufaturer been met?	<input type="checkbox"/>	<input type="checkbox"/>	<input type="checkbox"/>
Is this a Primary/Secondary system?	<input type="checkbox"/>	<input type="checkbox"/>	<input type="checkbox"/>
Is the system pump operating properly with adequate flow in system?	<input type="checkbox"/>	<input type="checkbox"/>	<input type="checkbox"/>
Are the boiler pumps wires to the boiler pump contacts?	<input type="checkbox"/>	<input type="checkbox"/>	<input type="checkbox"/>
Is this a Full Flow system?	<input type="checkbox"/>	<input type="checkbox"/>	<input type="checkbox"/>
If yes are there control valves?	<input type="checkbox"/>	<input type="checkbox"/>	<input type="checkbox"/>
If yes are they wired to the boiler pump contacts?	<input type="checkbox"/>	<input type="checkbox"/>	<input type="checkbox"/>
If PVC venting is being used is the CPVC starter peice installed?	<input type="checkbox"/>	<input type="checkbox"/>	<input type="checkbox"/>

Special Jobsite Requirements (safety, health, etc...)

Date | 4/25/2018
Job | ATC Sanctuary Cultivator Phase
2
Location | Littleton, MA
Rep | HTS NEW ENGLAND
(PEABODY)
Engineer
Contractor



Innovent is a business of



Tag	Innovent Model #
ERU-5A	LASER-1-OU-PL-12000-CW-CW-HW-460
ERU-8AB	LASER-1-OU-PL-12000-CW-CW-HW-460
ERU-5B	LASER-1-OU-PL-12000-CW-CW-HW-460
ERU-6AB	LASER-1-OU-PL-12000-CW-CW-HW-460
ERU-7AB	LASER-1-OU-PL-12000-CW-CW-HW-460

Table of Contents

<u>Contents</u>	<u>Page #</u>
Primary Information	
Performance Data Summary	
ERU-5A, ERU-8AB, ERU-5B, ERU-6AB, ERU-7AB	3
Fan Curve	
ERU-5A, ERU-8AB, ERU-5B, ERU-6AB, ERU-7AB Return Fan	4
Unit Drawing	
ERU-5A, ERU-8AB, ERU-5B, ERU-6AB, ERU-7AB	5
Airflow Schematic	
ERU-5A, ERU-8AB, ERU-5B, ERU-6AB, ERU-7AB	6
Specification	8
Curb Detail	
ERU-5A, ERU-8AB, ERU-5B, ERU-6AB, ERU-7AB	10
Base/Curb Detail	
ERU-5A, ERU-8AB, ERU-5B, ERU-6AB, ERU-7AB	11
Drain Connection/Trap Detail	
ERU-5A, ERU-8AB, ERU-5B, ERU-6AB, ERU-7AB	12
Power Electrical Schematic	13
ETL Authorization to Mark	14
Innovent Standard Warranty	16
Terms and Conditions	17

Performance Data Summary

ERU-5A, ERU-8AB, ERU-5B, ERU-6AB, ERU-7AB

MODEL							ALTITUDE (Ft)					
LASER-1-OU-PL-12000-CW-CW-HW-460							0.00					
RETURN FILTER										OUTSIDE		
CFM	TYPE	DEPTH (in)	FACE VEL. (FPM)	MERV	QTY	WIDTH (in)	HEIGHT (in)	CLEAN PD	TOTAL PD			
12000	Pleated	2	450	8	8	20	24	0.58	1.54			
12000	Cartridge	12	450	15	8	20	24					
RETURN FAN										OUTSIDE		
QTY	CFM	CLASS	SIZE (mm)	TYPE	TSP ("WC)	BHP	MHP	RPM	MOTOR RPM	VFD Hz	MOTOR TYPE	
2	6000	N/A	500	Plenum	7.04	9.5	15.0	2450	1800	84.0	TEFC	
TOTAL:	12000	-	-	-	7.04	18.9	30.0	-	-	-	-	
TSP CALCULATION												
SA ESP ("WC)		2.00	Return Filter Loading PD ("WC)			0.96	Post Cooling Chilled Water Coil ("WC)			0.24		
Casing Loss ("WC)		0.30	Plate Heat Exchanger ("WC)			1.54	Hot Water Coil ("WC)			0.09		
Return Filter Clean PD ("WC)		0.58	Dehumidification Coil ("WC)			1.33	TSP:			7.04 "WC		
PLATE HEAT EXCHANGER										SUPPLY & RETURN		
OUTSIDE AIR DATA					RETURN AIR DATA							
MODE	CFM	EAT (DB/WB)(°F)	LAT (DB/WB)(°F)	PD	CFM	EAT (DB/WB)(°F)	LAT (DB/WB)(°F)	PD				
Cooling	12000	78.0/63.5	58.2/56.4	1.54	12000	46.5/46.5	66.2/55.1	0.76				
MODEL: H-1-50B-2100												
DEHUMIDIFICATION COIL												SUPPLY
CFM	FPM	EAT (DB/WB)(°F)	LAT (DB/WB)(°F)	MBH (T/S)	GPM	GLYCOL %	EWT (°F)	LWT (°F)	WPD (ft)	ROWS	FPI	PD
12000	496	58.2/56.4	46.4/46.4	308.9/155.1	94	30% PG	40.0	47.0	15.0	8	11	1.33
POST COOLING CHILLED WATER COIL												RETURN
CFM	FPM	EAT (DB/WB)(°F)	LAT (DB/WB)(°F)	MBH (T/S)	GPM	GLYCOL %	EWT (°F)	LWT (°F)	WPD (ft)	ROWS	FPI	PD
12000	496	64.5/55.0	54.4/50.8	132.2/132.2	41	30% PG	40.0	47.0	10.5	3	7	0.24
HOT WATER COIL												SUPPLY
CFM	FPM	EAT (°F)	LAT (°F)	MBH	GPM	GLYCOL %	EWT (°F)	LWT (°F)	WPD (ft)	ROWS	FPI	PD
12000	496	65.0	87.4	292	31	30% PG	180.0	160.0	9.4	1	7	0.09
ELECTRICAL INFORMATION										UNIT POWER		
COMPONENT				VOLTS	PHASE	FREQ. (Hz)	MOP	MCA				
Electrical Enclosure				460	3	60	50	40.7				
AMP SUMMARY												
Return Fan				18.1 x 2	--	--	Total:				36.2	

Fan Curve

ERU-5A, ERU-8AB, ERU-5B, ERU-6AB, ERU-7AB Return Fan

APD-500

Volume Per Fan (CFM)	6,000	Total Volume (CFM)	12,000	Drive Loss (%)	-
External SP (in. wg)	2.00	Total SP (in. wg)	7.04	Static Efficiency (%)	70.17
Elevation (ft.)	0	Brake Horsepower (bhp)	18.94	Fan Manufacturer	Greenheck
Airstream Temp. (F)	68.0	Fan RPM	2450	Fan Size (mm)	500
Motor Horsepower (hp)	30.0	Max Fan Speed (RPM)	2900		

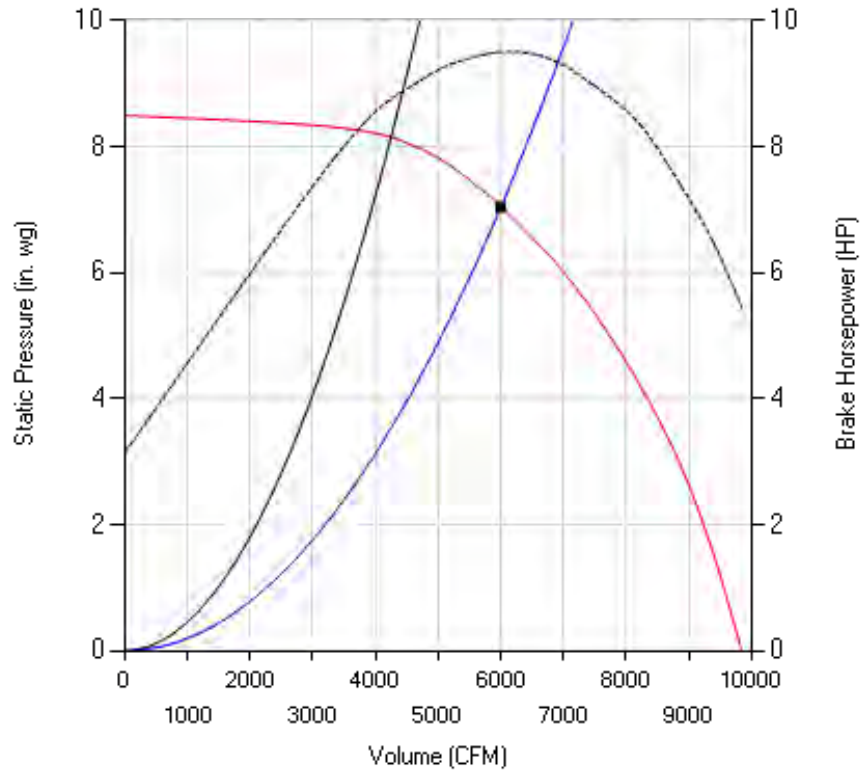

Sound Power by Octave Band

Sound Data	62.5	125	250	500	1000	2000	4000	8000	LwA	dBA
Inlet	89	88	98	87	87	86	82	80	94	85
Outlet	93	90	99	96	97	90	86	81	100	91

Fan arrays display sound data for the array.

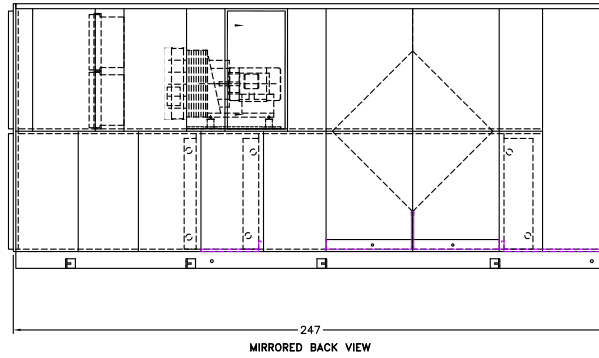

COMPONENTS:

- 1.) COIL CONDENSATE DRAIN (1 1/4" MPT, TYP. OF 2)
- 2.) CONDENSATE DRAIN (1" MPT, TYP. OF 2)
- 3.) VFD CABINET
- 4.) CONTROL PANEL/MAIN DISCONNECT
- 5.) 2" MERV 8 RETURN AIR PRE-FILTER
- 6.) 12" MERV 15 RETURN AIR FINAL FILTER
- 7.) RETURN FAN ISOLATION DAMPER (TYP. OF 2)
- 8.) RETURN BLOWER/MOTOR ASSEMBLY (TYP. OF 2)
- 9.) INNOVENT HEAT EXCHANGER
- 10.) HOT WATER COIL
- 11.) POST COOL CHILLED WATER COIL
- 12.) DEHUMIDIFICATION COIL

WEIGHT:
10,400 LBS.

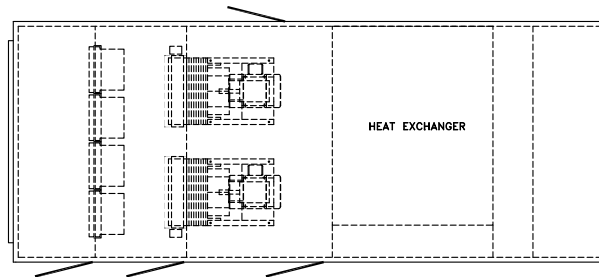

PLAN VIEW (UPPER)

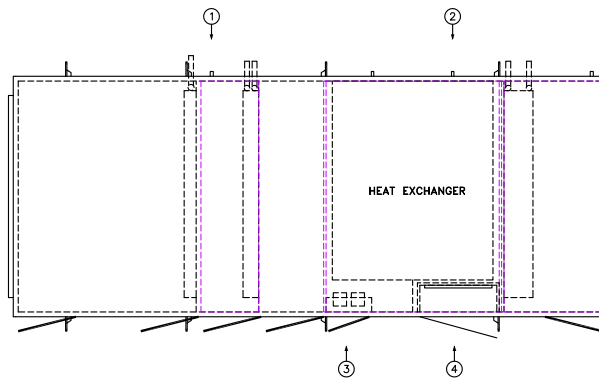

PLAN VIEW (LOWER)

RECOMMENDED CLEARANCES

- MINIMUM 12" IN FRONT OF ALL HOODS.
- MINIMUM 24" IN FRONT OF ALL LOUVERS.
- MINIMUM 40" IN FRONT OF ALL SERVICE ACCESS LOCATIONS.
- MINIMUM 36", OR AS LOCAL CODES DICTATE, IN FRONT OF ALL ELECTRICAL PANELS. EXTERNALLY MOUNTED PANELS CAN BE UP TO 16" DEEP.
- MINIMUM 48" ABOVE ALL CONDENSER FANS.
- MINIMUM 48" IN FRONT OF ALL CONDENSER COILS.
- COMPONENT REMOVAL MAY REQUIRE MORE SPACE THAN SHOWN ABOVE.

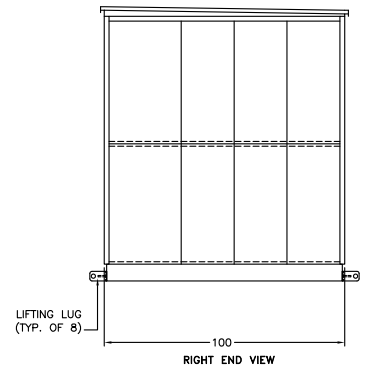
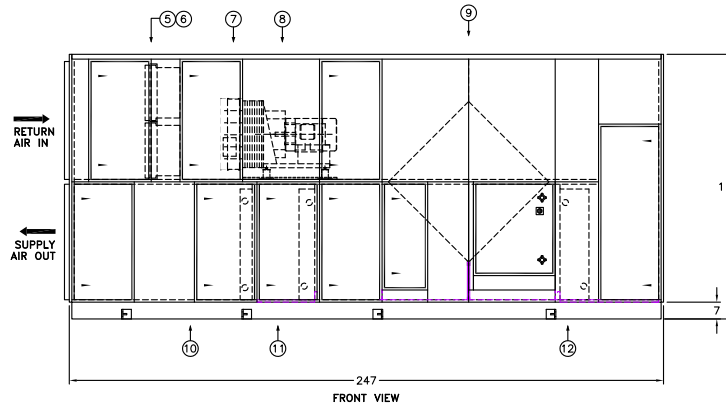
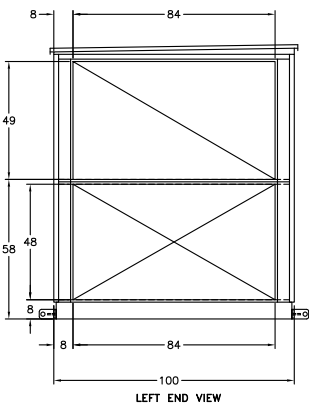

Innovent
Air Handling Equipment

ENGINEER: C. SAWYER		DESCRIPTION: UNIT DRAWING	
DRAWN BY:		PROJECT: ATC SANCTUARY CULTIVATOR PHASE 2	
CAS	JOB #	TAG #	REV #:
7792924		ERU-5A, ERU-5B, ERU-6AB, ERU-7AB, ERU-8AB	1-MMS
FILE NAME:	DATE:	MODEL #	
7792924UE8B	4/24/18	LASER-1-OU-PL-12000-CW-CW-HW-460	

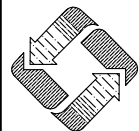
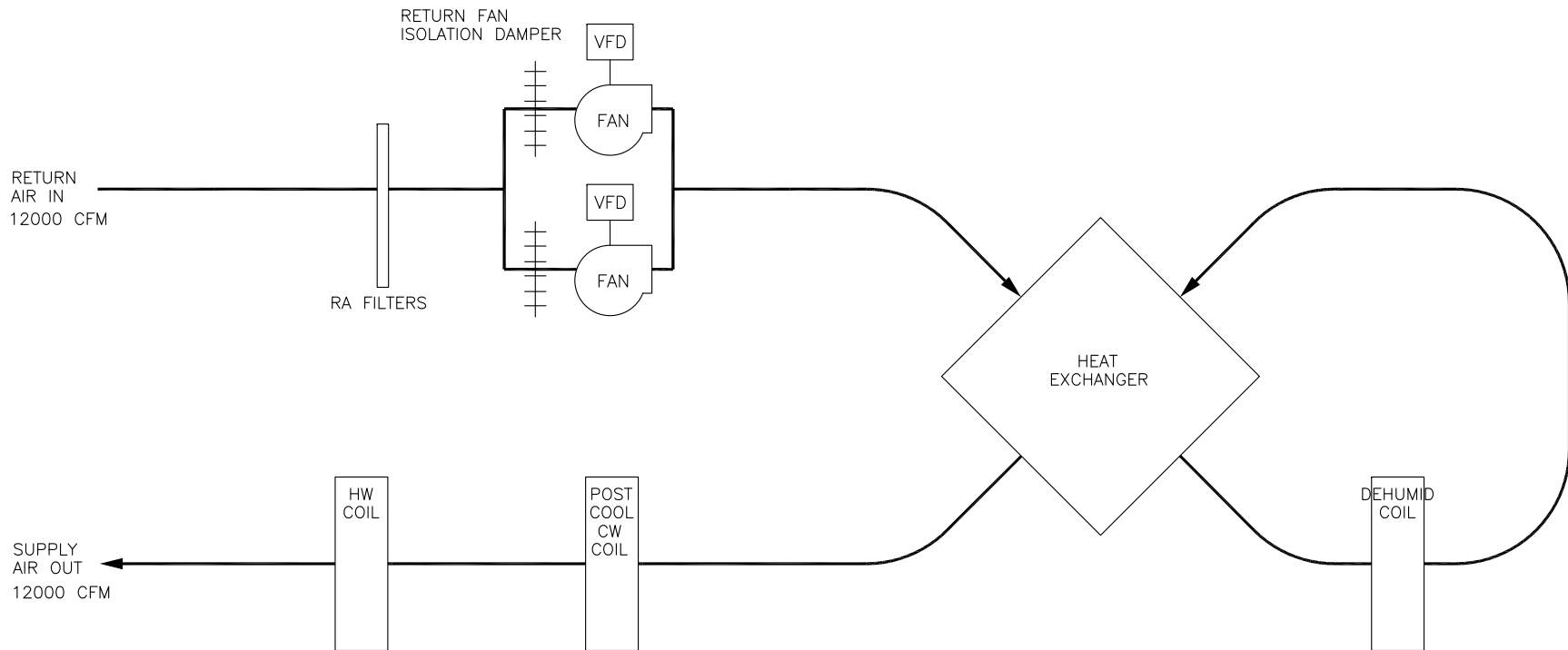

Innovent
Air Handling Equipment

ENGINEER:		DESCRIPTION:	
C. SAWYER		AIRFLOW SCHEMATIC	
DRAWN BY:		PROJECT:	
CES		ATC SANCTUARY CULTIVATOR PHASE 2	
JOB #		TAG #	
7792924		ERU-5A, ERU-5B, ERU-6AB, ERU-7AB, ERU-8AB	
FILE NAME:	DATE:	MODEL #	
7792924AE8B	4/24/18	SEE UNIT DRAWING FOR TAG TO MODEL # REFERENCE	
		REV #:	

Specification

ERU-5A, ERU-8AB, ERU-5B, ERU-6AB, ERU-7AB

ERU-5A, ERU-8AB, ERU-5B, ERU-6AB, ERU-7AB: CONSTRUCTION

CASING

- SMACNA leakage class rating of 5.0
- Maximum panel deflection shall not exceed L/250 at design total static pressure
- Minimum R-13 insulation value for walls, ceilings, and flooring
- 2" thick double wall thermal-break panels, 22 gauge high performance polyester painted steel (Innovent standard gray) outer wall, 22 gauge galvanized steel inner wall
- 2 lb/ft³ polyurethane foam injected insulation in the walls and ceiling
- Designed for outdoor installation
- 22 gauge high performance polyester painted steel (Innovent standard gray) pitched roof
- Unit shall ship in one piece

FLOOR

- Floor shall be 2" thick paneled construction with 18 gauge galvanized steel walk-on surface and 22 gauge galvanized steel underside of paneled floor (not exposed to air stream)
- 2 lb/ft³ polyurethane foam injected insulation
- The unit construction described above will not accommodate a plenum style curb

FRAME & STRUCTURAL BASE

- Frame and panel construction provided with a mix of galvanized steel and aluminum structural tube framing members
- 10 ga coated welded steel structural base
- Lifting lugs mounted on unit base

ACCESS

- Double wall insulated access doors with stainless steel hinges, corrosion resistant compression latches
- Doors shall be tool lockable
- Doors shall have pressure relief safety latches (doors that open with pressure)

UNIT INLETS/OUTLETS

- Return air inlet with duct connection
- Supply air outlet with duct connection

ERU-5A, ERU-8AB, ERU-5B, ERU-6AB, ERU-7AB: COMPONENTS

PLATE HEAT EXCHANGER

- Aluminum sensible cross flow flat plate heat exchanger
- Smooth aluminum plates separated by formed ribs
- Aluminum frame and end plates
- Stainless steel drain pan

HOT WATER COIL

- Hot water coil galvanized steel casing, 0.02 thick copper tubes, and 0.006 thick aluminum fins
- Supply and return connections supplied with copper sweat fittings
- Water control valve is provided by others and field mounted by others

DEHUMIDIFICATION COIL

- Chilled water coil stainless steel casing, 0.02 thick copper tubes, and 0.008 thick aluminum fins
- Stainless steel IAQ drain pan
- Supply and return connections supplied with grooved steel connection
- Water control valve is provided by others and field mounted by others

POST COOLING CHILLED WATER COIL

- Chilled water coil stainless steel casing, 0.02 thick copper tubes, and 0.006 thick aluminum fins
- Stainless steel IAQ drain pan
- Supply and return connections supplied with copper sweat fittings
- Water control valve is provided by others and field mounted by others

RETURN FAN

- Backward inclined plenum fan, welded and coated steel wheel
- AMCA certified ratings for sound and performance
- Direct drive assembly
- 1" spring isolated unitary fan/motor base, flex connectors provided at fan inlet
- TEFC premium efficiency motors
 - VFD-rated with class F insulation

RETURN FILTER

- 2" pleated MERV 8 filter
- 12" cartridge MERV 15 filter
- Front access filter rack construction to be galvanized steel

DAMPERS

- Return fan isolation: galvanized steel formed blade, galvanized steel frame, two-position actuator

ERU-5A, ERU-8AB, ERU-5B, ERU-6AB, ERU-7AB: ELECTRICAL

- Unit ETL listed as a complete package, unit factory wired to unit mounted NEMA 3R control panel
- Major electrical components UL listed (non-fused disconnect switch, control circuit fusing, control circuit transformer, fan motor starters, and overloads as applicable)
- Power wiring enclosed in conduit
- Single point power connection
- Unit shall have a short circuit current rating (SCCR) of 5 kA
- A VFD per return fan is provided by Innovent and factory installed by Innovent
 - No manual bypass included
 - Variable frequency drive shall be ventilated by the unit airstream

ERU-5A, ERU-8AB, ERU-5B, ERU-6AB, ERU-7AB: CONTROLS

- DDC controls are provided and installed by others. Innovent will not provide, mount or wire the following control devices:
 - Transformers
 - Relays/Contactors
 - Water valves/actuators
 - DDC/PLC boards
 - Control panel (power panel provided by Innovent does NOT have space for controls components)
- Minimum control points required:
 - Return Fan
 - Start/Stop control requires one ON/OFF contact per VFD
 - One 0-10VDC control signal required per VFD
 - Post Cooling Chilled Water Coil
 - Valve provided by others
 - Hot Water Coil
 - Valve provided by others
 - Dehumidification Coil
 - Valve provided by others
 - Return Fan Isolation Damper
 - 2-Position actuator(s) require switched 24VAC power
 - Actuators provided with endswitches
- Sensors/transducers/switches are provided and installed by others.

ERU-5A, ERU-8AB, ERU-5B, ERU-6AB, ERU-7AB: ADDITIONAL UNIT DETAILS

EQUIPMENT MOUNTING

- Roof curb by others

Specification

ETL Listing

- ANSI/U.L. 1995: Heating and Cooling Equipment

WARRANTIES

- All Innovent warranties begin at equipment start up or 6 months from shipment, whichever occurs first. If the warranties need to be extended from what is shown, please contact the factory for pricing.
- 1 year PARTS ONLY unit warranty is provided per Innovent's standard warranty terms

FACTORY TESTING/REPORTS

- Standard run testing done (consult factory for more details)

CURB DETAIL DRAWING

QUANTITY	TAG(S)	DIMENSIONAL DATA	H	MATERIAL	UNIT WT.	CURB WT.
5	ERU-5A, ERU-5B, ERU-6AB, ERU-7AB, ERU-8AB	K=92 1/2 L=239 1/2 A=118 15/16	N/A	GALV.	10,400 LBS	N/A

CURB BY OTHERS

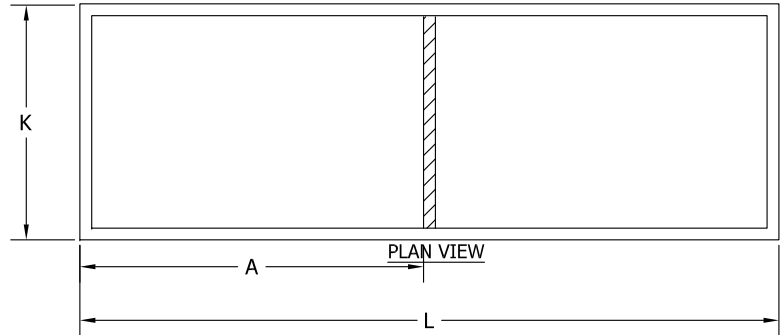

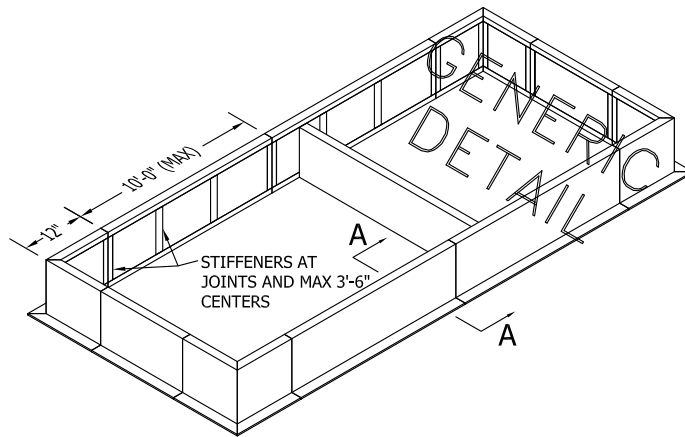

CROSS MEMBER KEY

-  ANGLE IRON CROSS BRACE  RECESSED 1" BELOW PERIMETER
-  ANGLE IRON CROSS BRACE  FLUSH WITH PERIMETER

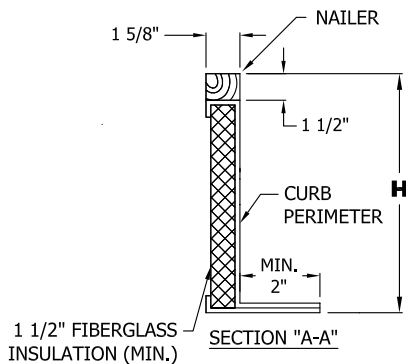

NOTES:
1.) NOT TO SCALE



	ENGINEER:	DESCRIPTION:
	C. SAWYER	CURB DETAIL DRAWING
	DRAWN BY:	PROJECT:
	CAS	ATC SANCTUARY CULTIVATOR PHASE 2
JOB #	TAG #	REV #:
7792924	SEE SCHEDULE ABOVE	
FILE NAME:	DATE:	MODEL #
7792924CE8B	4/25/18	SEE UNIT DRAWING FOR TAG TO MODEL # REFERENCE

TAG(S)	O.D. UNIT	O.D. BASE	O.D. CURB	A1	A2
ERU-5A, ERU-5B, ERU-6AB, ERU-7AB, ERU-8AB	247"L x 100"W	245"L x 98"W	239 1/2"L x 92 1/2"W	1 1/8"	1"

CURB BY OTHERS

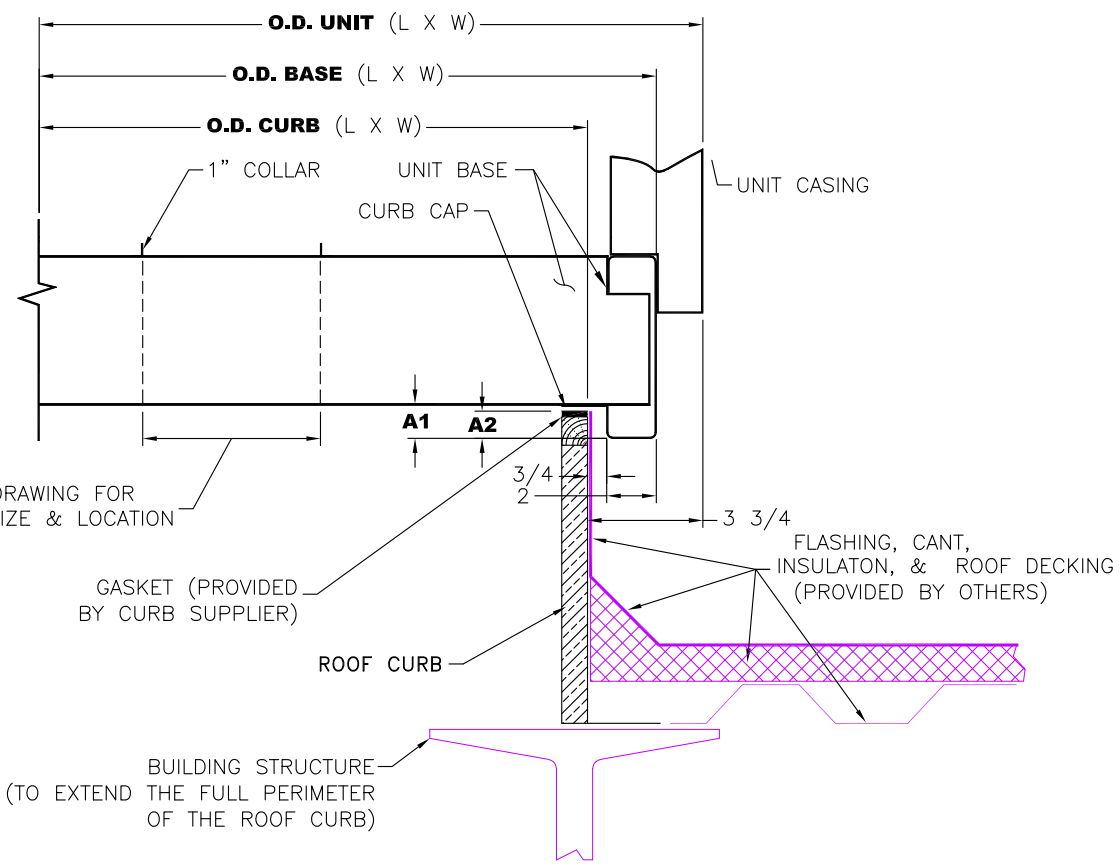

CONTRACTOR INSTALLED DUCT CONNECTION DETAILS

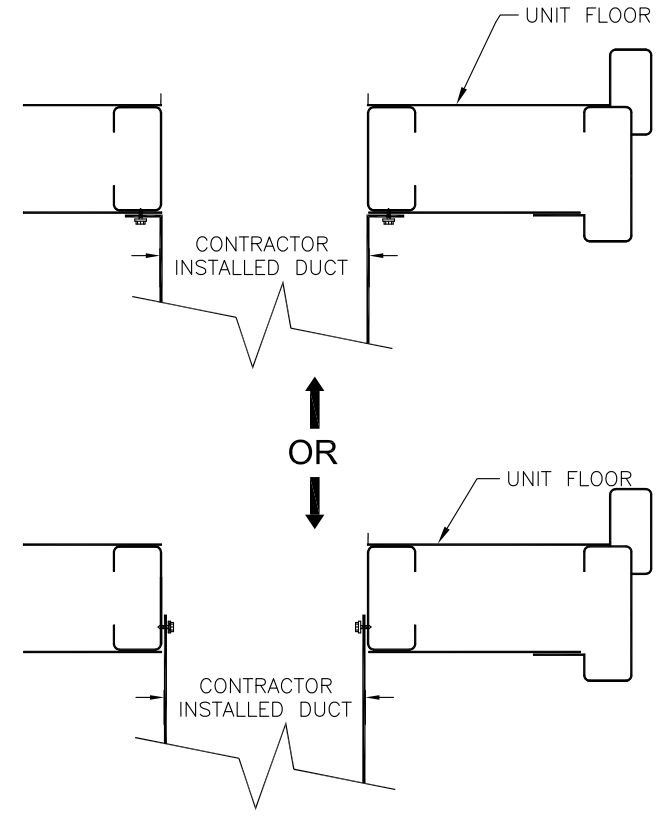

	ENGINEER:	DESCRIPTION:		
	C. SAWYER	BASE/CURB DETAIL		
	DRAWN BY:	PROJECT:		
	CAS	ATC SANCTUARY CULTIVATOR PHASE 2		
	JOB #	TAG #		
7792924	SEE SCHEDULE ABOVE			REV #:
FILE NAME:	DATE:	MODEL #		
7792924BE8B	4/25/18	SEE UNIT DRAWING FOR TAG TO MODEL # REFERENCE		

SIDE DRAIN CONNECTION

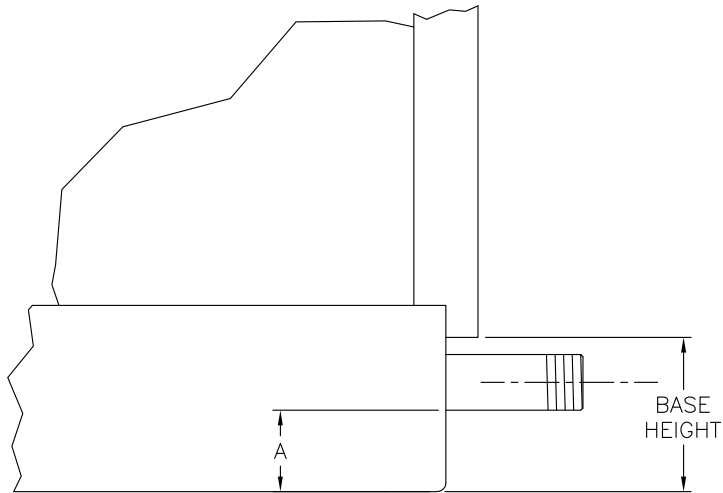

BOTTOM DRAIN CONNECTION

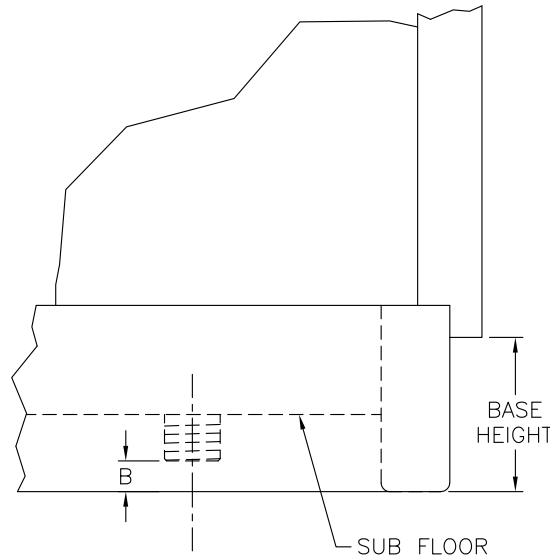

NOTE: REFER TO UNIT DRAWING TO DETERMINE WHETHER CONNECTION IS THROUGH BOTTOM AND/OR SIDE OF UNIT.

BASE HEIGHT	DRAIN SIZE (MPT)	"A"	"B"
4 1/2"	1"	1 1/4"	1/8"
5"	1"	1 3/4"	1/8"
		1"	
6"	1"	2 3/4"	1/8"
		1"	
7"	1"	3 3/4"	1/8"
		3"	
9"	1"	5 3/4"	1/8"
		5"	
11"	1"	4 5/8"	1/8"
		7 3/4"	
		7"	
		6 5/8"	

RECOMMENDED DRAIN TRAP DESIGN (TRAP BY OTHERS)

POSITIVE PRESSURE TRAP*
(BLOW THRU FAN)

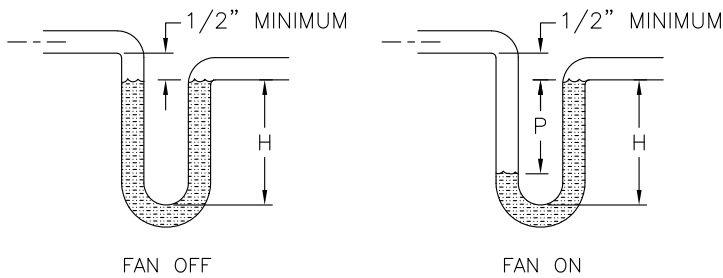

P = POSITIVE FAN PRESSURE (" W.C.)
H = P + (1/2" MINIMUM)

NEGATIVE PRESSURE TRAP*
(DRAW THRU FAN)

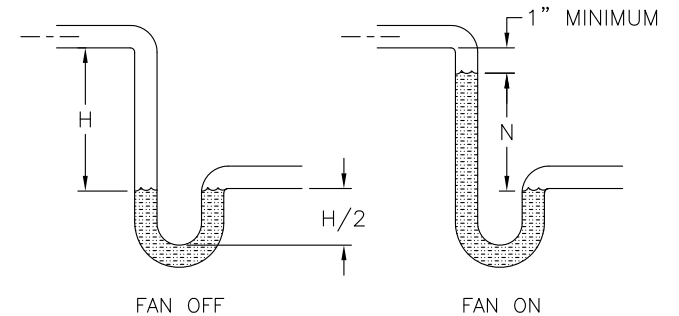

N = NEGATIVE FAN PRESSURE (" W.C.)
H = N + (1" MINIMUM)

*NOTE: A CONSERVATIVE METHOD OF TRAP HEIGHT DESIGN IS TO SET N=TSP AND P=TSP (TSP=TOTAL STATIC PRESSURE)



ENGINEER:
C. SAWYER
DRAWN BY:
CAS
JOB #
7792924
FILE NAME:
7792924TE8B

DESCRIPTION:
DRAIN CONNECTION/TRAP DETAIL
PROJECT:
ATC SANCTUARY CULTIVATOR PHASE 2
TAG #
SEE UNIT DRAWING
MODEL #
SEE UNIT DRAWING FOR TAG TO MODEL # REFERENCE
REV #:

6 Gas connections

Table 6B Natural Gas Pipe Size Chart

TABLE - 6B Capacity of Schedule 40 Metallic Pipe in Cubic Feet of Natural Gas Per Hour (based on .60 specific gravity, 0.30" w.c. pressure drop)														
Pipe Size (Inches)	Length of Pipe in Straight Feet													
	10	20	30	40	50	60	70	80	90	100	125	150	175	200
1 1/4	1,060	726	583	499	442	400	368	343	322	304	269	244	224	209
1 1/2	1,580	1,090	873	747	662	600	552	514	482	455	403	366	336	313
2	3,050	2,090	1,680	1,440	1,280	1,160	1,060	989	928	877	777	704	648	602
2 1/2	4,860	3,340	2,680	2,290	2,030	1,840	1,690	1,580	1,480	1,400	1,240	1,120	1,030	960
3	8,580	5,900	4,740	4,050	3,590	3,260	3,000	2,790	2,610	2,470	2,190	1,980	1,820	1,700
4	17,500	12,000	9,660	8,270	7,330	6,640	6,110	5,680	5,330	5,040	4,460	4,050	3,720	3,460

Check inlet gas supply

⚠ WARNING DO NOT adjust or attempt to measure gas valve outlet pressure. Attempting to alter or measure the gas valve outlet pressure could result in damage to the valve, causing potential severe personal injury, death, or substantial property damage.

The gas piping must be sized for the proper flow and length of pipe, to avoid excessive pressure drop. Both the gas meter and the gas regulator must be properly sized for the total gas load.

If gas pressure drops more than 1 inch w.c. (249 Pa) between maximum and minimum input rate, the meter, regulator, or gas line may be undersized or in need of service. Perform the steps below when checking inlet gas supply:

1. Turn the main power switch to the "OFF" position.
2. Shut off gas supply at the manual gas valve in the gas piping to the appliance.
3. Remove the 1/8" pipe plug on the flange to the factory supplied gas shutoff valve and install a suitable 1/8" fitting (field supplied) for the manometer tubing. Place the tubing of the manometer over the tap once the 1/8" fitting is installed as shown in FIG. 6-4.
4. Slowly turn on the gas supply at the factory installed manual gas valve.
5. Turn the power switch to the "ON" position.
6. Adjust the temperature set point on the control panel of the SMART TOUCH control module to call for heat or utilize Service Mode, see page 50 of this manual.
7. Observe the gas pressure with the burner operating at 100% of rated input. Without turning off the boiler, reduce the burner to the minimum input rate and observe the gas pressure with the burner at the minimum input rate. Percent of burner input will be displayed on the Modulation Screen.
8. Ensure inlet pressure is within specified range. Minimum and maximum gas supply pressures are specified in this section of the manual.
9. If gas supply pressure is within normal range and no adjustments are needed, proceed on to Step 11.
10. If the gas pressure is out of range, contact the gas utility, gas supplier, qualified installer or service agency to determine the necessary steps to provide proper gas pressure to the control.
11. Turn the power switch to the "OFF" position.
12. Shut off the gas supply at the manual gas valve in the gas piping to the appliance.
13. Remove the manometer from the pressure tap on top of the gas valve. Remove the 1/8" (3 mm) field supplied fitting and reinstall the pipe plug removed in Step 3.

6 Gas connections *(continued)*

WARNING Use two wrenches when tightening gas piping at boiler (FIG. 6-2), using one wrench to prevent the boiler gas line connection from turning. Failure to support the boiler gas connection pipe to prevent it from turning could damage gas line components.

Figure 6-2 Inlet Pipe with Backup Wrench

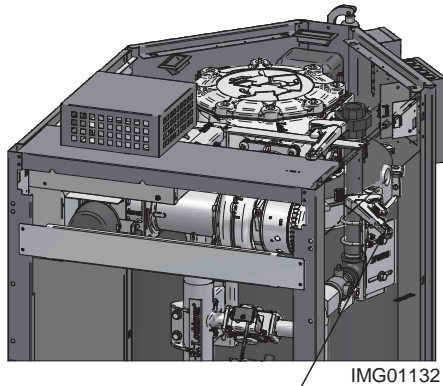

USE BACK UP WRENCH TO PREVENT PIPE FROM ROTATING

NOTICE Maximum inlet gas pressure must not exceed the value specified. Minimum value listed is for the purposes of input adjustment.

Natural gas:

WARNING Check boiler rating plate to determine which fuel the boiler is set for. Crest boilers CANNOT be field converted. Failure to comply could result in severe personal injury, death, or substantial property damage.

Pipe sizing for natural gas

- Refer to Table 6B for pipe length and diameter. Based on rated boiler input (divide by 1,000 to obtain cubic feet per hour).
 - Table 6B is only for natural gas with specific gravity 0.60, with a pressure drop through the gas piping of 0.3 inches w.c.
 - For additional gas pipe sizing information, refer to the National Fuel Gas Code, NFPA 54 / ANSI Z223.1 - latest edition, or in Canada CSA B149.1 Installation Code.

Natural gas supply pressure requirements

- Target a supply pressure of 7 inches w.c. (1.7 kPa) measured when the boiler is operating at minimum input rate. Gas pressure can be adjusted higher or lower than 7 inches w.c. as needed.
- Pressure required at the gas valve inlet pressure port:
 - Maximum 14 inches w.c. (3.5 kPa) with boiler operating.
 - Minimum 4 inches w.c. (.99 kPa) with boiler operating.

- Install 100% lockup gas pressure regulator in supply line for each boiler if inlet pressure exceeds 14 inches w.c. (3.5 kPa).
- Gas valves used on Crest boilers are rated for at least 27 inches w.c. (6.7 kPa).

Propane Gas:

WARNING Check boiler rating plate to determine which fuel the boiler is set for. Crest boilers CAN NOT be field converted. Failure to comply could result in severe personal injury, death, or substantial property damage.

Pipe sizing for propane gas

- Contact gas supplier to size pipes, tanks, and 100% lockup gas pressure regulator.

Propane Supply Pressure Requirements

- Target a supply pressure of 11 inches w.c. (2.7 kPa) measured when the boiler is operating at minimum input rate. Gas pressure can be adjusted higher or lower than 11 inches w.c. as needed.
- Adjust propane supply regulator provided by the gas supplier for 14 inches w.c. (3.5 kPa) maximum pressure.
- Pressure required at gas valve inlet pressure port:
 - Maximum 14 inches w.c. (3.5 kPa) with boiler operating.
 - Minimum 4 inches w.c. (.99 kPa) with boiler operating.

Figure 6-3 Gas Supply Piping to Regulator

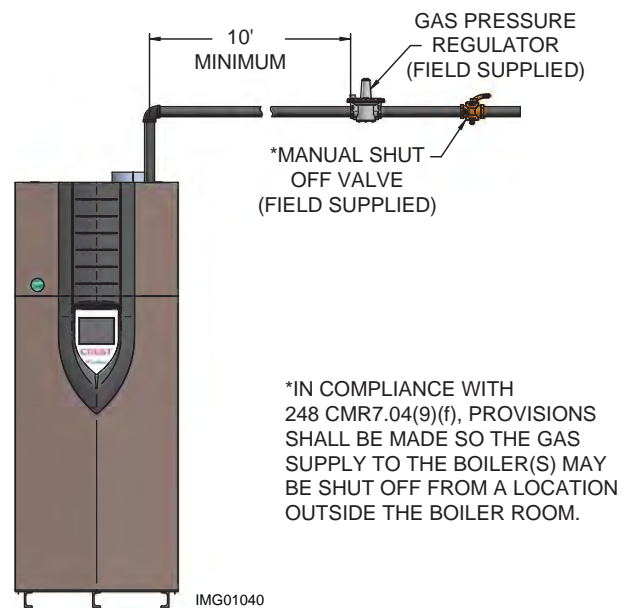

6 Gas connections

Gas supply

NOTICE

Ensure that the high gas pressure regulator is at least 10 feet (3 m) upstream of the appliance.

1. It is recommended to install one (1) gas regulator for each Crest boiler.
2. Gas regulators should be installed in a horizontal orientation unless otherwise recommended by the regulator manufacturer.
3. It is recommended to install a filter at the inlet of a gas regulator to prevent debris from entering the regulator.
4. Gas regulators should be installed the greater of either 20 inches or 10 pipe diameters from the nearest fitting, elbow, or valve to the outlet of the regulator.
5. It is recommended that the gas regulator outlet size match the gas inlet size of the boiler and to not change the pipe size between them. If the pipe diameter must be increased, a bell reducer type fitting should be located at the regulator outlet and the boiler inlet, maintaining the distance indicated in Step 4.
6. Gas regulators must be properly vented to ensure proper function:
 - a. Vent pipe must be no smaller than the regulator vent connection size.
 - b. Each regulator must have a separate vent line.
 - c. Vent lines must not be combined together or with any other equipment that also requires atmospheric vents.
 - d. Excessive gas regulator vent length will detrimentally affect regulator performance:
 - Gas regulators must be properly vented according to the regulator manufacturer’s instructions.
 - It is recommended that regulator vent length not exceed 15 equivalent feet (4.5 m).
 - When regulator vent must exceed 15 equivalent feet, it is recommended to use a ventless regulator equipped with a vent limiter.
 - If a ventless regulator cannot be utilized, it is recommended to increase vent diameter by one pipe size after the initial 15 equivalent feet and every additional 10 equivalent feet.
 - e. Proper measures must be taken to prevent water, snow, insects, or other debris from obstructing the vent.

Connecting gas supply piping

NOTICE

For dual fuel models, reference the Crest Dual Fuel Supplemental Manual.

1. Refer to FIG. 6-1 to pipe gas to the boiler.
 - a. Install ground joint union for servicing, when required.
 - b. In Canada – When using manual main shutoff valves, it must be identified by the installer.

Figure 6-1 Gas Supply Piping

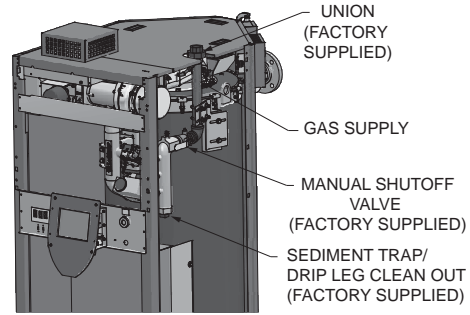

2. Support piping with hangers, not by the boiler or its accessories.

WARNING

The gas valve and blower will not support the weight of the piping. Do not attempt to support the weight of the piping with the boiler or its accessories. Failure to comply could result in severe personal injury, death, or substantial property damage.

3. Purge all air from the gas supply piping.
4. Before placing the boiler in operation, check the boiler and its gas connection for leaks.
 - a. The appliance must be disconnected from the gas supply piping system during any pressure testing of that system at a test pressure in excess of 1/2 PSIG (3.5 kPa).
 - b. The appliance must be isolated from the gas supply piping system by closing a manual shutoff valve during any pressure testing of the gas supply piping system at test pressures equal to or less than 1/2 PSIG (3.5 kPa).
 - c. The appliance and its gas connection must be leak tested before placing it in operation.

WARNING

Do not check for gas leaks with an open flame – use the bubble test. Failure to use the bubble test or check for gas leaks can cause severe personal injury, death, or substantial property damage.

5. Use pipe sealing compound compatible with propane gases. Apply sparingly only to male threads of the pipe joints so that pipe dope does not block gas flow.

WARNING

Failure to apply pipe sealing compound as detailed in this manual can result in severe personal injury, death, or substantial property damage.

Table 6A Gas Inlet Size

Model	Gas Inlet Size
FB0751	1 1/4"
FB1001	1 1/4"
FB1251	1 1/4"
FB1501	1 1/2"
FB1751	1 1/2"
FB2001	1 1/2"

8 Condensate disposal

Condensate drain

1. The Crest is a high efficiency appliance that produces condensate.
2. The rear of the boiler has a 1 inch (25.4 mm) stainless steel drain fitting and a 3/8 inch (9.8 mm) stainless steel vent line for connection to the condensate trap.
3. Connect the 1 inch (25.4 mm) fitting to the 1 inch (25.4 mm) fitting on the condensate trap with the factory supplied silicone hose. Secure the hose to the condensate trap and the boiler using the factory supplied hose clamps.
4. Connect the 3/8 inch (9.8 mm) fitting to the 3/8 inch (9.8 mm) fitting on the condensate trap (shipped loose) with the factory supplied silicone hose. Secure the hose to the condensate trap and the boiler using the factory supplied hose clamps.
5. The condensate trap must be installed at the same level or below the boiler base.
6. The condensate trap is sized for a 1" PVC outlet connection pipe.
7. Plug the wiring connection from the condensate trap into the connector located on the back of the unit.
8. Slope condensate tubing down and away from the boiler into a drain or condensate neutralizing filter. Condensate from the Crest will be slightly acidic (typically with a pH from 3 to 5). Install a neutralizing filter if required by local codes.

A neutralizer kit (FIG. 8-1) is available from the factory (#100157652). The neutralizer kit must be placed on a surface that is a minimum of 3 inches lower than the condensate trap with field supplied piping (vacuum break) installed between the condensate trap and the neutralizer kit.

9. Do not expose condensate line to freezing temperatures.

NOTICE

Use materials approved by the authority having jurisdiction. In the absence of other authority, PVC and CPVC pipe must comply with ASTM D1785 or D2845. Cement and primer must comply with ASME D2564 or F493. For Canada use CSA or ULC certified PVC or CPVC pipe, fittings, and cement.

NOTICE

To allow for proper drainage on large horizontal runs, a second line vent may be required and tubing size may need to increase to 1 inch (25 mm).

The condensate line must remain unobstructed, allowing free flow of condensate. If condensate is allowed to freeze in the line or if the line is obstructed in any other manner, condensate can exit from the boiler tee, resulting in potential water damage to property.

10. A condensate removal pump is required if boiler is below the drain. When installing a condensate pump, select one approved for use with condensing boilers and furnaces. The pump should have an overflow switch to prevent property damage from condensate spillage. The switch should be wired to the auxiliary device proving switch terminals on the low voltage connection board.

Figure 8-1 Condensate Disposal

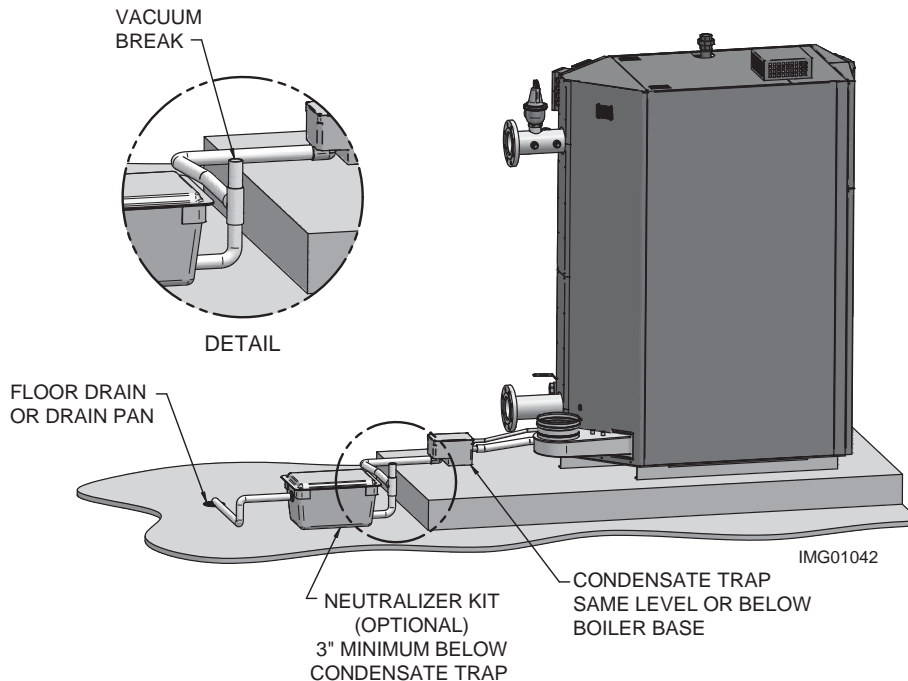

7 Field wiring

⚠ WARNING ELECTRICAL SHOCK HAZARD – For your safety, turn off electrical power supply before making any electrical connections to avoid possible electric shock hazard. Failure to do so can cause severe personal injury or death.

NOTICE Wiring must be N.E.C. Class 1. If original wiring as supplied with boiler must be replaced, use only type 105°C wire or equivalent.

Boiler must be electrically grounded as required by National Electrical Code ANSI/NFPA 70 – latest edition.

⚠ CAUTION Label all wires prior to disconnection when servicing controls. Wiring errors can cause improper and dangerous operation.

Line voltage connections

1. Connect 120 VAC power wiring to the line voltage terminal strip in the junction box, as shown in FIG. 7-1.
2. Provide and install a fused disconnect or service switch sized per the boiler amp draw (shown on the boiler rating plate) as required by the code (see FIG. 7-1).
3. When connecting the boiler, system and hot water generator pumps connect the wiring to the line voltage terminal strip as shown in FIG. 7-1. Maximum current is 1.5 amps. Install a field supplied contactor between the pump(s) and the boiler connections.
4. For alternate voltages, consult factory.

Installation must comply with:

1. National Electrical Code and any other national, state, provincial, or local codes, or regulations.
2. In Canada, CSA C22.1 Canadian Electrical Code Part 1, and any local codes.

Figure 7-1 Boiler Line Voltage Field Wiring Connections

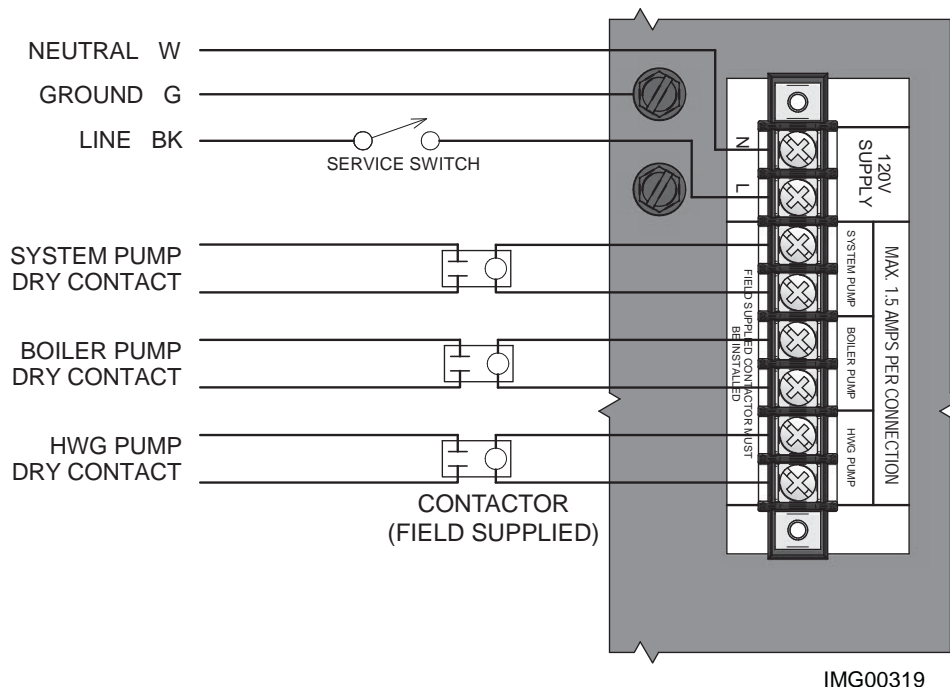

7 Field wiring (continued)

Figure 7-3 Low Voltage Field Wiring Connections

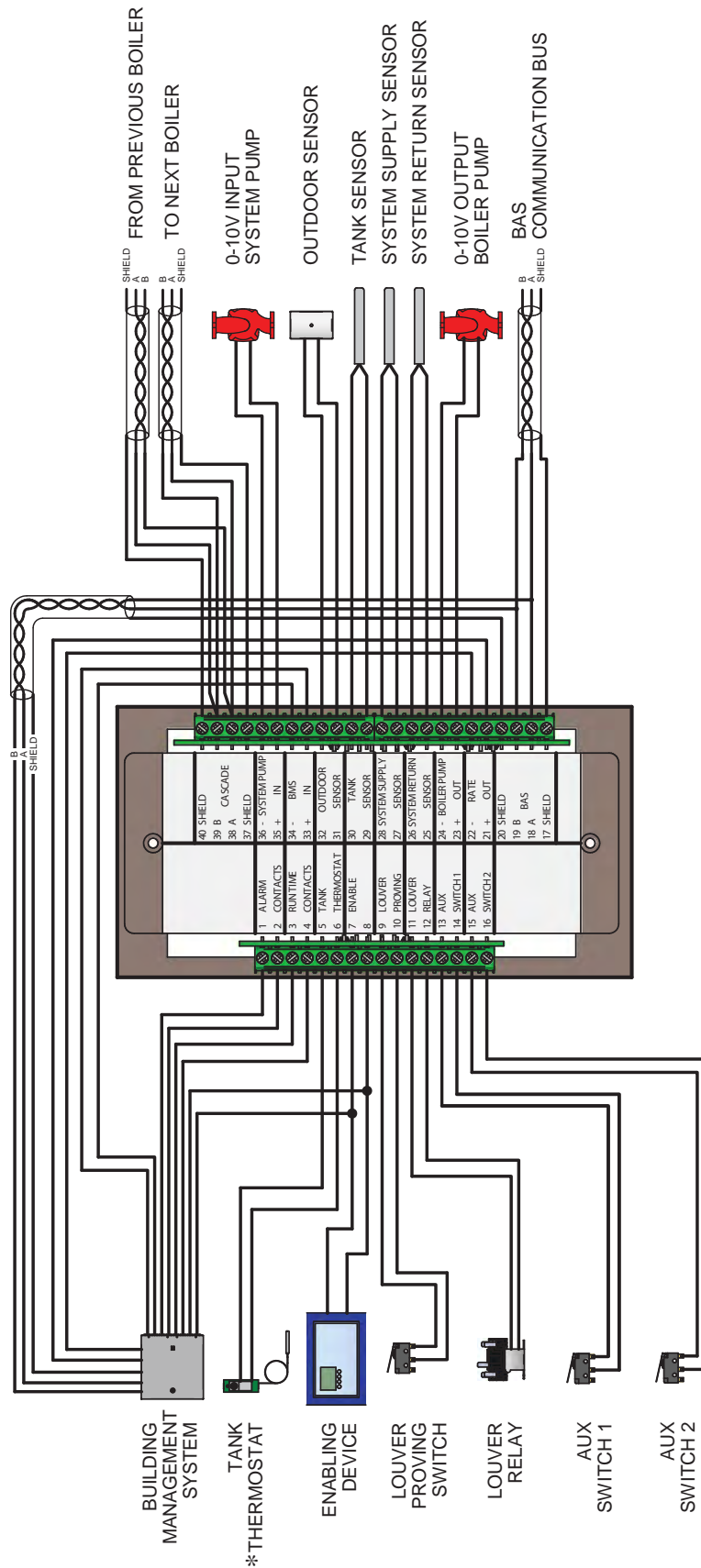

* See page 19 for special instructions when common venting Crest boilers.

5 BACnet Memory Map

Available BMS Points List

Primary Data Tables

Object Type	Data Type	Read / Write
Binary Input (BI)	Single Bit	Read Only
Binary Value (BV)	Single Bit	Read / Write
Analog Input (AI)	16-Bit Word	Read Only
Analog Value (AV)	16 Bit Word	Read / Write

Memory Map

Object Name	Object Type	Object Instance	Units	Min	Max	Resolution
Binary Values						
Boiler Enable	BV	0	none	0	1	1
Tank Thermostat	BV	4	none	0	1	1
Binary Inputs						
Manual Reset High Limit	BI	0	none	0	1	1
Flow Switch	BI	1	none	0	1	1
Gas Pressure Switch	BI	2	none	0	1	1
Louver Proving Switch	BI	3	none	0	1	1
Air Pressure Switch	BI	4	none	0	1	1
Blocked Drain Switch	BI	5	none	0	1	1
Flame 1	BI	7	none	0	1	1
Enable	BI	8	none	0	1	1
Tank Thermostat	BI	9	none	0	1	1
Fan 1 Proving Switch	BI	10	none	0	1	1
Fan 2 Proving Switch	BI	12	none	0	1	1
Flue Damper Switch	BI	20	none	0	1	1
Flame 2	BI	22	none	0	1	1
Run Time Contacts	BI	32	none	0	1	1
Alarm Contacts	BI	33	none	0	1	1
Boiler Pump	BI	34	none	0	1	1
DHW Pump	BI	35	none	0	1	1
Louver Relay	BI	36	none	0	1	1
Gas Valve 1	BI	37	none	0	1	1
System Pump	BI	38	none	0	1	1
Flue Damper Output	BI	43	none	0	1	1
Gas Valve 2	BI	45	none	0	1	1
Transition Gas Valve**	BI	46	none	0	1	1
Main Fan 1	BI	48	none	0	1	1
Main Fan 2*	BI	49	none	0	1	1
External Spark / HSI	BI	50	none	0	1	1
Air Valve Trigger**	BI	51	none	0	1	1
Air Valve Proving**	BI	52	none	0	1	1

* Crest Models 2500 - 6000 Only

** Crest Models 751- 1501 Only

5 BACnet Memory Map

Memory Map *(continued)*

Object Name	Object Type	Object Instance	Units	Min	Max	Resolution
Inputs						
Binary Inputs 0-15	AI	0	none	0	65535	1
Binary Inputs 16-31	AI	1	none	0	65535	1
Binary Inputs 32-47	AI	2	none	0	65535	1
System / Cascade Setpoint	AI	3	Deg. C	0	130	0.5
System Pump Speed	AI	4	Percent	0	100	1
Cascade Total Power	AI	5	Percent	100	800	1
Cascade Current Power	AI	6	Percent	0	800	1
Outlet Setpoint	AI	7	Deg C	0	130	0,5
Outlet Temperature	AI	8	Deg C	0	130	0,1
Inlet Temperature	AI	9	Deg C	-20	130	0,1
Flue Temperature	AI	10	Deg C	-20	130	0,1
Firing Rate	AI	11	Percent	0	100	1
Boiler Pump Speed	AI	12	Percent	0	100	1
Boiler Status Code	AI	13	none	0	65535	1
Boiler Blocking Code	AI	14	none	0	65535	1
Boiler Lockout Code	AI	15	none	0	65535	1
Binary Inputs 48-63	AI	25	none	0	65535	1
Lock-Out Error Leader	AI	26	none	0	1	1
Lock-Out Error Member 1	AI	27	none	0	1	1
Lock-Out Error Member 2	AI	28	none	0	1	1
Lock-Out Error Member 3	AI	29	none	0	1	1
Lock-Out Error Member 4	AI	30	none	0	1	1
Lock-Out Error Member 5	AI	31	none	0	1	1
Lock-Out Error Member 6	AI	32	none	0	1	1
Lock-Out Error Member 7	AI	33	none	0	1	1
Analog Values						
Configuration	AI	0	none	0	65535	1
Coils	AI	1	none	0	65535	1
0-10 Volt Input / Rate Command / Setpoint Command	AI	2	Percent	0	100	1
Tank Setpoint	AI	3	Deg C	0	87,5	0,5
Tank Temperature	AI	4	Deg C	-20	130	0,1
Outdoor Temperature	AI	5	Deg C	-40	60	0,1
System Supply Temperature	AI	6	Deg C	-20	130	0,1
System Return Temperature	AI	7	Deg C	-20	130	0,1

Ratings



Crest AHRI Rating					Other Specifications						
Model Number <small>Note: Change "N" to "L" for L.P. gas models.</small>	Input MBH <small>(Notes 4 - 6)</small>		Gross Output MBH <small>(Note 1)</small>	Net AHRI Ratings Water, MBH <small>(Note 2)</small>	Appliance Water Content Gallons	Pipe Size Outlet	Pipe Size Inlet	Gas Inlet Size	Air Size	Vent Size <small>(Note 3)</small>	Weight w/Water (lbs.)
	Min	Max									
FB(N,L)0751	50	750	720	626	73	3"	3"	1 1/4"	6"	6"	1768
FB(N,L)1001	50	1000	960	835	77	3"	3"	1 1/4"	6"	6"	1838
FB(N,L)1251	62	1250	1200	1043	87	3"	3"	1 1/4"	6"	8"	1975
FB(N,L)1501	60	1500	1440	1252	94	4"	4"	1 1/2"	8"	8"	2307
FB(N,L)1751	70	1750	1680	1460	106	4"	4"	1 1/2"	8"	8"	2458
FB(N,L)2001	80	2000	1920	1670	111	4"	4"	1 1/2"	8"	8"	2570



NOTICE Maximum allowed working pressure is located on the rating plate.

Notes:

1. The ratings are based on standard test procedures prescribed by the United States Department of Energy.
2. Net AHRI ratings are based on net installed radiation of sufficient quantity for the requirements of the building and nothing need be added for normal piping and pickup. Ratings are based on a piping and pickup allowance of 1.15.
3. Crest boilers require special gas venting. Use only the vent materials and methods specified in the Crest Installation and Operation Manual.
4. Standard Crest boilers are equipped to operate from sea level to 4,500 feet **only**. The boiler will de-rate by 1.4% for each 1,000 feet above sea level up to 4,500 feet.
5. High altitude Crest Models are equipped to operate from 3,000 to 12,000 feet **only**. The boiler will not de-rate up to 5,500 feet and will de-rate by 1.6% for each 1,000 feet above 5,500 feet. The operation given in this manual remains the same as the standard boilers. A high altitude label (as shown in FIG A.) is also affixed to the unit.
De-rate values are based on proper combustion calibration and CO₂'s adjusted to the recommended levels.

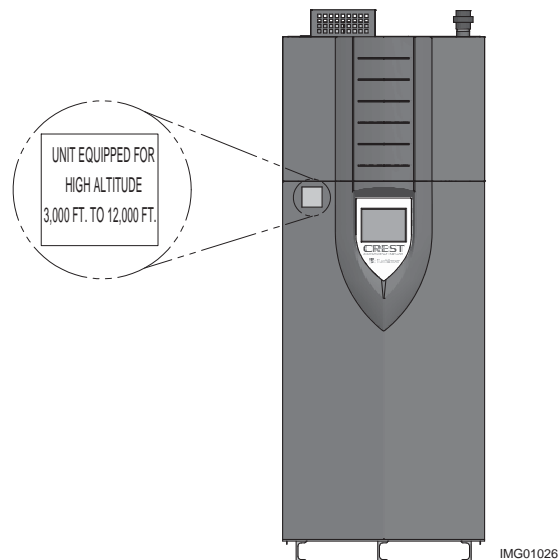

Figure A High Altitude Label Location

Certificate of Product Ratings

AHRI Certified Reference Number: 8005810

Date: 6/26/2017

†Status: Active

Product: Commercial Boiler Heating Equipment

Model Number: FBN2001

Manufacturer: LOCHINVAR, LLC

Trade/Brand name: LOCHINVAR

Series Name: Crest

Rated as follows in accordance with Department of Energy (DOE) Boiler test procedures as published in the latest edition of the Code of Federal Regulations, 10 CFR Part 431 and subject to verification of rating accuracy by AHRI-sponsored, independent, third party testing:

Combustion Efficiency:	96.4 %
Thermal Efficiency:	96.2 %

The following data is for reference only and is not certified by AHRI:

Material:	Stainless Steel
Location:	Indoor
Fuel Type:	Natural Gas
Input:	2000 MBTUH
Gross Output:	1924 MBTUH
Ignition Type:	Intermittent/Electronic Ignition
Heating Medium:	Water
Draft Type:	Forced Draft
CO2:	9.6

* Ratings followed by an asterisk (*) indicate a voluntary rerate of previously published data, unless accompanied with a WAS, which indicates an involuntary rerate.

DISCLAIMER

AHRI does not endorse the product(s) listed on this Certificate and makes no representations, warranties or guarantees as to, and assumes no responsibility for, the product(s) listed on this Certificate. AHRI expressly disclaims all liability for damages of any kind arising out of the use or performance of the product(s), or the unauthorized alteration of data listed on this Certificate. Certified ratings are valid only for models and configurations listed in the directory at www.ahridirectory.org.

TERMS AND CONDITIONS

This Certificate and its contents are proprietary products of AHRI. This Certificate shall only be used for individual, personal and confidential reference purposes. The contents of this Certificate may not, in whole or in part, be reproduced; copied; disseminated; entered into a computer database; or otherwise utilized, in any form or manner or by any means, except for the user's individual, personal and confidential reference.

CERTIFICATE VERIFICATION

The information for the model cited on this certificate can be verified at www.ahridirectory.org, click on "Verify Certificate" link and enter the AHRI Certified Reference Number and the date on which the certificate was issued, which is listed above, and the Certificate No., which is listed at bottom right.

©2014 Air-Conditioning, Heating, and Refrigeration Institute



we make life better™

CERTIFICATE NO.: 131429620408624139

Minimum Requirements Document



Customer	Sanctuary Medicinals	Electric PA	Municipal	Application #	
Facility	234 Taylor St, Littleton	Gas PA	National Grid	Application #	7676228

This Minimum Requirements Document (“MRD”) states the minimum equipment specifications and operational requirements of the energy saving equipment and system(s) planned for the project identified above per the project’s design documents. Equipment and systems shall be installed per the minimum requirements in this document to ensure that the demand and energy savings estimated in the Mass Save engineering analysis/energy model are realized. Upon construction completion, Mass Save Program Administrators will verify that these minimum requirements are met before making incentive payments. Verification may include a physical post inspection walk through and review of documents and trend data identified in these MRDs.

The Energy Conservation Measures (ECMs) in this project provide both electric and gas savings (as applicable). The ECMs and associated fuel savings are listed in the table below. A separate detailed MRD for each ECM follows on subsequent pages.

Energy Conservation Measures	Electric	Gas
ECM 1: Phase 1 Flower Room HVAC	<input type="checkbox"/>	<input checked="" type="checkbox"/>
ECM 2:	<input type="checkbox"/>	<input type="checkbox"/>
ECM 3:	<input type="checkbox"/>	<input type="checkbox"/>
ECM 4:	<input type="checkbox"/>	<input type="checkbox"/>
ECM 5:	<input type="checkbox"/>	<input type="checkbox"/>
ECM 6:	<input type="checkbox"/>	<input type="checkbox"/>
ECM 7:	<input type="checkbox"/>	<input type="checkbox"/>
ECM 8:	<input type="checkbox"/>	<input type="checkbox"/>
ECM 9:	<input type="checkbox"/>	<input type="checkbox"/>
ECM 10:	<input type="checkbox"/>	<input type="checkbox"/>

In the event there are to be changes to the equipment and systems described in these MRDs, customers must notify the Mass Save Program Administrators of the expected changes prior to the equipment purchase and installation, as the change in design and operation may affect the available incentive and anticipated energy savings.

Pre-Installation		Post-Installation	
Signature	Date	Signature	Date
Customer			
Electric PA			
Gas PA			

Minimum Requirements Document



Customer	Sanctuary Medicinals	Electric PA	Municipal	Application #	
Facility	234 Taylor St, Littleton	Gas PA	National Grid	Application #	7676228

ECM 1:	Phase 1 Flower Room HVAC
---------------	--------------------------

Yes/No checkboxes are intended for use as program administrator's post-installation inspection record (check one).

EQUIPMENT: Provide a list of equipment or materials installed as part of this project. Include equipment counts, HP, kW, efficiency and capacity ratings, rating conditions, location of controls hardware, etc.

	Project Design Intent	Post Inspection Findings
Yes <input type="checkbox"/> No <input type="checkbox"/>	1. Install two 12,000 cfm air handling units in each of four flower rooms (101, 102, 103, 104). Each unit shall have CHW (25.7 tons) and HW coils (292 kBtu/h), one set of filters, a blow-through fan, and a heat recovery core.	
Yes <input type="checkbox"/> No <input type="checkbox"/>	2. The heat recovery section shall be able to reduce reheat loads by 63% during light and dark periods.	
Yes <input type="checkbox"/> No <input type="checkbox"/>	3. The heat recovery section shall be able to reduce cooling loads by 41% light periods and 50% dark periods.	

SEQUENCES OF OPERATION: Provide a description of equipment operating sequences, setpoints, operating schedules, balancing requirements (flow, velocity, head, etc.) or any other required operating parameters. Describe requirements separately.

Yes <input type="checkbox"/> No <input type="checkbox"/>	4. <u>Fan Control:</u> The supply fans shall operate continuously throughout the year.	
Yes <input type="checkbox"/> No <input type="checkbox"/>	5. <u>Heat Recovery Control:</u> Heat recovery shall be operational during all fan operating hours.	
Yes <input type="checkbox"/> No <input type="checkbox"/>	6. <u>Cooling Control:</u> Chilled water flow through the primary cooling coil shall be modulated to maintain a dewpoint condition in the spaces served. Savings are based on setpoints of 78°F/50% RH during light periods and 70°F/50% RH during dark periods. Multiple AHUs in each space shall be controlled in a coordinated manner to prevent fighting.	
Yes <input type="checkbox"/> No <input type="checkbox"/>	7. <u>Heating Control:</u> Hot water flow through the heating coils shall be modulated to maintain space temperature setpoints. Savings are based on setpoints of 78°F light period and 70°F dark period.	

DOCUMENTATION: List written documentation required to train, verify, operate, or maintain the equipment being installed or controlled. This may include specification sheets, test reports, construction drawings, etc.

Yes <input type="checkbox"/> No <input type="checkbox"/>	8. Copies of approved submittals for all equipment covered in this document.	
--	--	--

POST INSTALLATION VERIFICATION: Provide a list of controls and monitoring capabilities required to verify proper system operation. Trends should document operational sequences, set points and scheduling of equipment as described in TA Study.

Yes <input type="checkbox"/> No <input type="checkbox"/>	9. None.	
--	----------	--

Minimum Requirements Document



Customer	Sanctuary Medicinals	Electric PA	Municipal	Application #	
Facility	234 Taylor St, Littleton	Gas PA	National Grid	Application #	7676228

BASIS OF PRODUCTION: Describe the primary factors driving equipment loads used in the savings analysis. All areas used in reported values refer to canopy areas.

Yes <input type="checkbox"/> No <input type="checkbox"/>	10.	<i>Canopy Areas</i>			
		<u>Space Type</u>	<u>Area</u>	<u>Basis</u>	
		Veg	320 ft ²	(10) 4x8 trays	
		Flower	12,786 ft ²	(133) 3-tier, 4x8 trays	
		Mother	320 ft ²	(10) 4x8 trays	
Yes <input type="checkbox"/> No <input type="checkbox"/>	11.	<i>Light Levels & Duration</i>			
		<u>Space Type</u>	<u>PPFD</u>	<u>Duration</u>	
		Veg	760 μmol/m ² ·s	18 hr/day	
		Flower	930 μmol/m ² ·s	12 hr/day	
		Mother	700 μmol/m ² ·s	18 hr/day	
Yes <input type="checkbox"/> No <input type="checkbox"/>	12.	<i>Space Conditions</i>			
		<u>Parameter</u>	<u>Light</u>	<u>Dark</u>	
		Space Temp	78°F	70°F	
		Rel. Hum.	50%	50%	
		CO ₂	1,100 ppm	unregulated	
		Infiltration	0.10 ACH	0.05 ACH	
Yes <input type="checkbox"/> No <input type="checkbox"/>	13.	<i>Plant Daily Transpiration Disaggregation</i>			
		<u>Space Type</u>	<u>Light</u>	<u>Dark</u>	
		Veg	79%	21%	
		Flower	60%	40%	
		Mother	81%	19%	
Yes <input type="checkbox"/> No <input type="checkbox"/>	14.	<i>Other Sensible Equipment Loads</i>			
		<u>Space Type</u>	<u>Circ Fans W/ft²</u>	<u>Misc Loads W/ft²</u>	<u>CO₂ Gen kBtu/ft²</u>
		Veg	2.22	0.5	0.0
		Flower	2.22	0.2	0.0
		Mother	2.22	0.5	0.0
Yes <input type="checkbox"/> No <input type="checkbox"/>	15.	<i>Average Annual Loads on Central Equipment</i>			
		<u>Space Type</u>	<u>Condensation gal/day/ft²</u>	<u>Cooling ton·hrs/ft²</u>	<u>Heating kBtu/ft²</u>
		Veg	0.113	242	23.5
		Flower	0.196	211	18.5
		Mother	0.163	264	21.6

SOP: Cultivation protective eyewear	Company: Sanctuary Medicinals	RE V: 0000	8/20/20
-------------------------------------	-------------------------------	------------	---------

Purpose:

To ensure protective eyewear is used properly in the cultivation rooms.

Purchase and application:

- 1) Cultivation manager ensures proper eye protection is purchased based on the type of light being used within the grow.
- 2) Cultivation manager ensures proper supply of protective eyewear is given to all cultivation staff and that extra glasses are supplied at the beginning of the cultivation hallway.
- 3) Cultivation manager trains all cultivation staff on the importance and proper use of glasses in the grow rooms while the lights are on.
- 4) A sign signifying eyewear must be used when lights are on is clearly displayed in the



hall.

- 5)

Revision Table:

Revision Date	Revision Number	Reason for Revision	Revision Sign Off
20AUG20	0000	Setting up Template, writing first draft	NS

Power Electrical Schematic

ERU-5A, ERU-8AB, ERU-5B, ERU-6AB, ERU-7AB

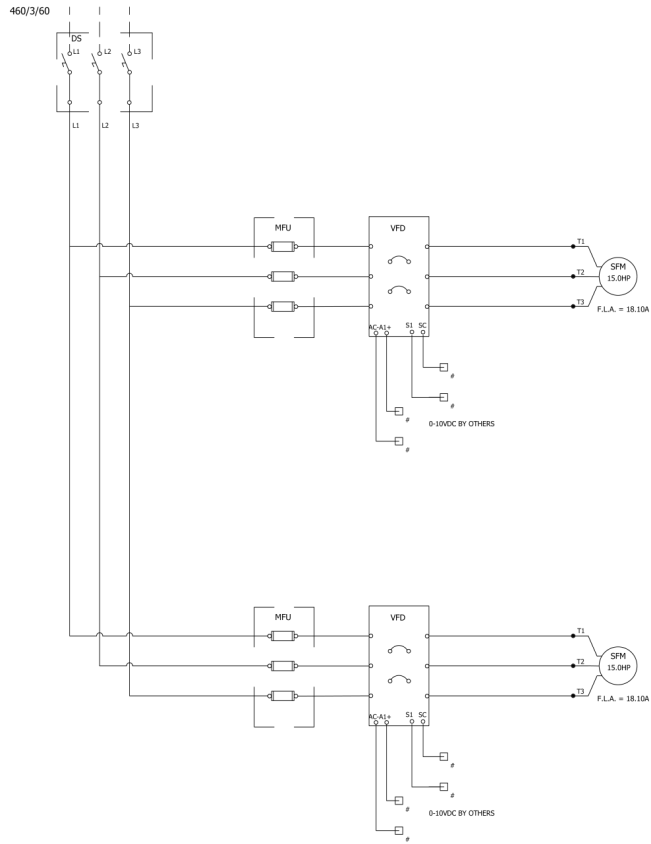

- FACTORY WIRING
- FIELD WIRING
- WIRE NUT
- SCREW TERMINAL
- ⊙ TERMINAL POINT BY OTHERS



AUTHORIZATION TO MARK

This authorizes the application of the Certification Mark(s) shown below to the models described in the Product(s) Covered section when made in accordance with the conditions set forth in the Certification Agreement and Listing Report. This authorization also applies to multiple listee model(s) identified on the correlation page of the Listing Report.

This document is the property of Intertek Testing Services and is not transferable. The certification mark(s) may be applied only at the location of the Party Authorized To Apply Mark.

Applicant: Unison Comfort Technologies
60 28th Avenue North
Address: Minneapolis, MN 55411

Country: USA
Contact: James Regan
Phone: (612) 877-4850
FAX: (612) 877-4851
Email: N/A

Manufacturer: Valent, LLC
60 28th Avenue North
Address: Minneapolis, MN 55411

Country: USA
Contact: James Regan
Phone: (612) 877-4850
FAX: (612) 877-4851
Email: N/A

Party Authorized To Apply Mark: Same as Manufacturer
Report Issuing Office: Columbus

Ellenfmialek

Control Number: 3061909

Authorized by: _____
for Thomas J. Patterson, Certification Manager



This document supersedes all previous Authorizations to Mark for the noted Report Number.

This Authorization to Mark is for the exclusive use of Intertek's Client and is provided pursuant to the Certification agreement between Intertek and its Client. Intertek's responsibility and liability are limited to the terms and conditions of the agreement. Intertek assumes no liability to any party, other than to the Client in accordance with the agreement, for any loss, expense or damage occasioned by the use of this Authorization to Mark. Only the Client is authorized to permit copying or distribution of this Authorization to Mark and then only in its entirety. Use of Intertek's Certification mark is restricted to the conditions laid out in the agreement and in this Authorization to Mark. Any further use of the Intertek name for the sale or advertisement of the tested material, product or service must first be approved in writing by Intertek. Initial Factory Assessments and Follow Up Services are for the purpose of assuring appropriate usage of the Certification mark in accordance with the agreement, they are not for the purposes of production quality control and do not relieve the Client of their obligations in this respect.

Intertek Testing Services NA Inc.
545 East Algonquin Road, Arlington Heights, IL 60005
Telephone 800-345-3851 or 847-439-5667 Fax 312-283-1672

Standard(s):	Standard for Safety for Heating and Cooling Equipment, ANSI/UL 1995, CAN/CSA C22.2 No.236-05 Third Edition, dated 02/18/2005 with revisions dated July 30, 2009 and Non-Recirculating Direct Gas-Fired Industrial Air Heaters ANSI Z83.4-2003/ CSA 3.7-2003 with addenda ANSI Z83.4a-2004/ CSA 3.7a-2004, ANSI Z83.4b-2006/ CSA 3.7b-2006
Product:	Heating and cooling, energy recovery and dehumidification equipment
Brand Name:	Retrovent, Valent, Innovent, Greenheck, or Accurex



AUTHORIZATION TO MARK

Models:

Series ERU, LASER, LASER-1, LASER-2, NDHU, CAHU and DDHU Energy Recovery and Custom Air Handling Units.

Series RWC, RWCU, RAC, RACU, and WW Remote Condenser and Remote Condensing Units.

Model Series VPR under Brand names: Valent, Innovent, Greenheck or Accurex. VPR may be followed by E, X, P or C followed by 110, 210, 310, 350 or 450 followed by A, B, or X followed by I, J, T, or X, followed by any number followed by A, B, or C.

Series RCD air handling units under Brand names: Retrovent, Valent, Innovent, Greenheck or Accurex. RCD fb 20, 25, 30, 40, 50, or 60 fb A,B,C, or D, fb 1, fb A-H, fb GH, GM, GL, EH, EM, EL, HW, ST, or AH fb 2-5, fb S or H, fb B,S,M, or N fb A-D, fb A-D, fb A-D, fb letters indicating other customer options

UNISON COMFORT TECHNOLOGIES LIMITED WARRANTY & DISCLAIMER POLICY

(Please read the Unison Comfort Technologies terms and conditions of sale Section 9 for additional details, conditions and exclusions.)

PRODUCT WARRANTY

Unison warrants that at the time of delivery and for a period of twelve (12) months from the initial startup or eighteen (18) months from the date of shipment, whichever is less, its products will be free from defects in materials and manufacture, provided that the products have been installed properly, maintained and operated under normal conditions and serviced in accordance with Unison's instructions, and are operating within capacities and ratings set forth in design specifications. **Labor or consumable parts are not included in this limited standard product warranty.** Consumable parts include, but are not limited to, refrigerant, belts and filters.

START-UP LABOR LIMITED WARRANTY

While labor is not included in the Unison standard product warranty, Unison offers a limited labor warranty, for a period beginning on the start-up date and continuing for sixty (60) days, with the completion and documentation of a qualified start-up. The limited labor warranty will not be available if the product warranty has expired.

Start-up services are included on all Innovent compressorized products, and may be available as an option on other Innovent products. These services must be performed by a Factory Certified Technician ("FCT"). Startup services include verifying proper operation of the unit, including proper refrigerant charge and repair of minor refrigerant leaks outside the coil. At the completion of start-up, an approved start-up record must be submitted to the Innovent service department for processing. Once the start-up record is received, the (60) day limited labor warranty, from date of start-up, will be activated. Labor associated with the diagnosis, validation and repair of warranty parts failures will be covered outside of the start-up, at a negotiated labor rate.

CONSIDERATIONS REGARDING PARTS-SUPPLIED-BY-OTHERS

Unison may supply equipment at a customer's request which has components, like controls, sensors, drives, which are engineered, provided, programmed or configured by other non-Unison parties. Unison does not provide a warranty for these parts or components. These components can be mounted in the factory or at the jobsite. In these instances, Unison's support is limited to verification of basic functionality of the components and not the overall operation or integration of the equipment within the overall building HVAC system. As stated in the Unison Terms & Conditions – *No warranty herein extended shall apply to repair or correction of conditions arising from improper or incorrectly connected air duct, piping, wiring, power supply, blown fuses, freezing, improper Product control when programmed by non-Seller controls, or personnel, or by anyone other than Seller employee or its representative.* In these situations, Unison will assist in the diagnosis of issues and provide support to the customer provided the customer issues a purchase order to cover Unison's expenses in doing so.

UNISON COMFORT TECHNOLOGIES TERMS & CONDITIONS OF SALE

ALL SALES ARE SUBJECT TO THESE UNISON COMFORT TECHNOLOGIES TERMS AND CONDITIONS OF SALES ("TERMS") AND AS CONTAINED IN UNISON'S INVOICE AND ARE ALSO SUBJECT TO UNISON'S CREDIT AND OTHER POLICIES AND PROCEDURES, WHICH ARE HEREBY INCORPORATED BY REFERENCE AND SUBJECT TO CHANGE.

1. TERMS TO GOVERN: These Terms shall be binding upon Unison Comfort Technologies, LLC and its subsidiaries and affiliates ("Seller") and the buyer ("Buyer"). No modification, amendment or change, whether in Buyer's purchase order, shipping release forms or otherwise shall obligate Seller, unless authorized in writing by Seller. Any different or inconsistent terms and conditions of sale contained in Buyer's forms, contracts or invoices are hereby superseded by these Terms.

2. ACCEPTANCE & PRICES: Any proposal offered by Seller to Buyer is valid for sixty (60) days. Upon the expiration of sixty (60) days, the proposal shall expire. Pricing shall remain valid for Seller's products ("Products") shipped within one hundred and twenty (120) days from the date of Seller's acceptance. Thereafter, prices are subject to change. Prices include transportation charges predicated on a single shipment and any partial shipments may result in additional cost to Buyer. Seller reserves the right, at any time, to withdraw a bid, quote or a price that contains an error.

3. PAYMENT & TAXES: Upon credit approval, payment terms for Products shipped hereunder or labor performed will be thirty (30) days net with no retainages unless contrary terms appear on the face hereof or otherwise expressly agreed to in writing by Seller. Should Buyer default in the timely payment to Seller of sums due on an order, Seller is entitled to any remedies provided in these Terms or by law. If Buyer fails to pay any amounts when due, Buyer shall pay Seller interest thereon at a periodic rate of the lesser of one and one-half percent (1.5%) per month or the maximum allowable legal interest rate, along with all costs and expenses (including without limitation reasonable attorneys' fees and disbursements and Court costs) incurred by Seller. Buyer is responsible for all sales, customs, or use tax imposed by any governmental agency, including, but not limited to, Federal, State, Local or international agencies payable on the transaction under any applicable statute, except those taxes due as a result of Seller's gross profits.

4. PERFORMANCE: Seller shall be obligated to furnish only the Products or labor described in the applicable purchase order or acknowledgement and agreed to in writing. The duty to perform under any order on the part of Seller and the price thereof is subject to the approval of its Credit Department, and is contingent upon the absence of strikes, accidents, floods, act(s) of terrorism, war, fires, fuel shortages, the inability to procure materials from the usual sources of supply, the requirements of the US Government (through the use of priorities or preference or any other manner) that Seller divert either the material or the furnished Product to the direct or indirect benefit of the US Government, or upon any like or unlike cause beyond the reasonable control of Seller. Upon disapproval of the Credit Department or upon the occurrence of any such event, Seller may delay performance or, at its option, renegotiate prices and terms and conditions of sale with Buyer. If Seller elects to renegotiate and Seller and Buyer are unable to agree on revised prices or terms, Seller may cancel without any liability.

5. SHIPMENT & RISK OF LOSS: Shipment dates are estimates only. Shipment shall be FOB factory with title passing to Buyer upon delivery to the carrier by Seller. Seller specifically rejects any order containing a time is of the essence clause or liquidated damage penalties for late shipments. Risk of loss, including but is not limited to loss of goods from shortages, damages or transit delays, shall pass to Buyer when the Products have been delivered to any transportation carrier (excluding proprietary transportation facilities of Seller). Any claims for damage to, or loss or misdelivery or damage of the Products shall be filed with Seller.

6. CHANGES, CANCELLATION & RETURNS: Changes requested by Buyer following Seller's acceptance of order must be approved by Seller in writing and may result in an increase in price deemed appropriate by Seller to recover all associated labor and material costs, including normal overhead and profit. If any portion of a Seller accepted order is cancelled by Buyer without default on the part of Seller or without Seller's written consent, Buyer shall be liable to Seller for cancellation charges including, but not limited to, Seller's incurred costs and such profit as would have been realized by Seller from the transaction had the agreement not been breached by Buyer. Products shall not be returned except by written permission of Seller pursuant to Seller's return policy.

7. AUTHORITY OF AGENTS: No agent, employee or representative of Seller has the authority to bind Seller to any affirmation, representation or warranty concerning the Product or labor sold, except for Seller's authorized agents, employees or representatives.

8. INDEMNITY: Seller shall protect and indemnify Buyer from and against all claims, damages, judgments and loss arising from infringement or alleged infringement of any United States patent by any of the articles or material delivered hereunder, provided that in the event of suit or threat of suit for patent infringement, Seller shall promptly be notified and given full opportunity to negotiate a settlement. Seller does not warrant against infringement by reason of Buyer's design of the articles or the use thereof in combination with other materials, or in the operation of any process. In the event of litigation, Buyer agrees reasonably to cooperate with Seller. All parties concerned shall be entitled, in connection with any proceeding under the provisions of this Article, to be represented by counsel at their own expense. Seller shall also defend, indemnify and hold harmless Buyer from any third party personal injury, wrongful death or property damage caused solely by Seller's negligent act(s). Buyer shall defend, indemnify and hold Seller harmless from any personal injury, wrongful death or property damage caused by Buyer's negligent or intentional act(s).

9. LIMITED WARRANTY AND DISCLAIMER: Seller warrants that at the time of delivery and for a period of twelve (12) months from the initial startup ("Start-Up") or eighteen (18) months from date of shipment, whichever is less, Products will be free from defects in material and manufacture provided that Products have been installed with proper Start-Up, maintained and operated under normal conditions for service in accordance with the instructions of Seller, and that Products have the capacities and ratings set forth in Seller's design specifications. No warranty is made against corrosion, erosion or deterioration. At Seller's option, Seller's obligations and liabilities under this warranty are limited to repair of Products or replacement of components for Products not conforming to this warranty. Limited warranty does not cover labor for component replacement. Once Seller's service department has been notified and approved any warranty related service work, Seller will repair or replace components as needed and ship FOB factory. Seller shall not be obligated to pay for the cost of lost refrigerant. Consumable parts and Products that are consumable in nature are explicitly excluded from this warranty. Consumables include, but are not limited to, belts, filters, and refrigerant. No warranty or liability whatever shall attach to Seller until full payment has been received. No warranty herein extended shall apply to repair or correction of conditions arising from improper or incorrectly connected air duct, piping, wiring, power supply, blown fuses, freezing, improper Product control when programmed by non-Seller controls, or personnel, or by anyone other than Seller employee or its representative. Operation of Products for temporary conditioning of a building during construction without the written consent of an officer of the Seller immediately voids any warranty coverage. If the Product is replaced, the replacement may not be new, but will be in good working order and at least functionally equivalent to the item or Product replaced. The replacement assumes the warranty status of the replaced Product. The warranty period does not start over. **THIS LIMITED WARRANTY IS IMMEDIATELY VOIDED AND CANCELLED BY ANY MISUSE, NEGLIGENCE, FAILURE TO FOLLOW INSTRUCTIONS, OR MANUALS OF INSTALLATION OR MAINTENANCE REPAIR, SERVICE, RELOCATION OR ALTERATION TO OR OF, OR OTHER TAMPERING WITH, THE PRODUCTS PERFORMED BY ANY PERSON OR ENTITY OTHER THAN SELLER WITHOUT SELLER'S PRIOR WRITTEN APPROVAL OR ANY USE OF REPLACEMENT PARTS NOT SUPPLIED BY SELLER WITH RESPECT TO THE AFFECTED PRODUCTS. BACK CHARGES RESULTING FROM CLAIMS UNDER THE WARRANTY SHALL BE RECOGNIZED ONLY WHEN PREVIOUSLY AUTHORIZED IN WRITING BY SELLER. THE WARRANTY AND LIABILITY SET FORTH HEREIN ARE IN LIEU OF ALL OTHER WARRANTIES AND LIABILITIES WHETHER IN CONTRACT, TORT, OR IN NEGLIGENCE, EXPRESSED OR IMPLIED, IN LAW OR IN FACT, INCLUDING IMPLIED WARRANTIES OF MERCHANTABILITY AND FITNESS FOR A PARTICULAR USE. SELLER PROVIDES NO INDEPENDENT WARRANTY FOR THIRD PARTY PRODUCTS OR COMPONENTS SOLD TOGETHER OR INCORPORATED WITH SELLER'S PRODUCTS(S).**

10. LIABILITY DISCLAIMER: TO THE MAXIMUM EXTENT PERMITTED BY LAW, SELLER'S TOTAL LIABILITY FOR CLAIMS, REGARDLESS OF THE FORM OF ACTION OR THEORY OF LIABILITY (INCLUDING CONTRACT, TORT OR WARRANTY), SHALL BE LIMITED TO THE FEES PAID TO SELLER BY BUYER FOR THE PRODUCTS OR LABOR ALLEGED TO CAUSE THE DAMAGE. IN NO EVENT SHALL SELLER BE LIABLE TO BUYER FOR ANY INCIDENTAL, CONSEQUENTIAL, SPECIAL, PUNITIVE, OR INDIRECT DAMAGES OF ANY KIND (INCLUDING, WITHOUT LIMITATION, LOST PROFITS, LOSS OF USE, OR CLAIMS OF THIRD PARTIES) THAT MIGHT OCCUR AS A RESULT OF THE PERFORMANCE OR BREACH OF THE AGREEMENT OR IN ANY WAY ARISING OUT OF OR IN CONNECTION WITH THE AGREEMENT.

11. ASSIGNMENT: No right or interest may be assigned by Buyer, nor may any obligation or performance delegated by Buyer without Seller's written permission. Any attempted assignment or delegation shall be void and ineffective for all purposes. Seller may assign its rights or obligations under this Agreement in the event of a merger or change of control of Seller.

12. GOVERNING LAW: This agreement shall be governed and construed in accordance with the laws State of Minnesota. Buyer consents to jurisdiction in the Circuit Court of Hennepin County, Minnesota.

13. EXPORT CONTROLS: Buyer shall comply with the export laws and regulations of the United States and other applicable jurisdictions with regard to Products and labor. Buyer agrees it shall not export or enter into an agreement for the export any goods from Seller to any prohibited or embargoed country or to any denied, blocked or restricted person or entity including those so designated by the US Dept. of Commerce or Treasury.

14. MISCELLANEOUS: In the event that any provision of this Agreement is held invalid by the final judgment of any court of competent jurisdiction, the remaining provisions shall remain in full force and effect as if such invalid provision had not been included herein. The waiver or failure of either party to enforce the terms of this Agreement in one or multiple instances shall not constitute a waiver of that party's rights under this Agreement with respect to other violations. The titles and headings used herein are for convenience only and do not constitute any part of this Agreement. Those sections of this Agreement, which by their nature are intended to survive, shall survive termination of this Agreement. The prevailing party may recover their attorney fees and reasonable out-of-pocket expenses.