



Massachusetts Cannabis Control Commission

Public Record Request

Marijuana Cultivator

General Information:

License Number: MC282178
Original Issued Date: 04/24/2020
Issued Date: 04/24/2020
Expiration Date: 04/24/2021

Payment Received: \$2500 Payment Required: \$2500

ABOUT THE MARIJUANA ESTABLISHMENT

Business Legal Name: Liberty Compassion, Inc

Phone Number: 401-273-8010 Email Address: vgiordano@libertycentersusa.com

Business Address 1: 179 Brook St Business Address 2:
Business City: Clinton Business State: MA Business Zip Code: 01510
Mailing Address 1: 10 Greene Street Mailing Address 2:
Mailing City: Providence Mailing State: RI Mailing Zip Code: 02903

CERTIFIED DISADVANTAGED BUSINESS ENTERPRISES (DBES)

Certified Disadvantaged Business Enterprises (DBEs): Not a DBE

PRIORITY APPLICANT

Priority Applicant: yes

Priority Applicant Type: RMD Priority

Economic Empowerment Applicant Certification Number:

RMD Priority Certification Number: RPA201968

RMD INFORMATION

Name of RMD: Liberty Compassion, Inc. (Formerly Liberty Compassion Center, Inc.)

Department of Public Health RMD Registration Number:

Operational and Registration Status: Obtained Provisional Certificate of Registration only

To your knowledge, is the existing RMD certificate of registration in good standing?: yes

If no, describe the circumstances below:

PERSONS WITH DIRECT OR INDIRECT AUTHORITY

Person with Direct or Indirect Authority 1

Percentage Of Ownership: Percentage Of Control: 20
Role: Executive / Officer Other Role:
First Name: Vincent Last Name: Giordano Suffix:
Gender: Male User Defined Gender:
What is this person's race or ethnicity?: White (German, Irish, English, Italian, Polish, French)
Specify Race or Ethnicity:

Person with Direct or Indirect Authority 2

Percentage Of Ownership: 10.55 Percentage Of Control: 20
Role: Board Member Other Role:
First Name: Richard Last Name: Baccari Suffix:
Gender: Male User Defined Gender:
What is this person's race or ethnicity?: White (German, Irish, English, Italian, Polish, French)
Specify Race or Ethnicity:

Person with Direct or Indirect Authority 3

Percentage Of Ownership: 10.55 Percentage Of Control: 20
Role: Board Member Other Role:
First Name: Michael Last Name: Kent Suffix:
Gender: Male User Defined Gender:
What is this person's race or ethnicity?: White (German, Irish, English, Italian, Polish, French)
Specify Race or Ethnicity:

Person with Direct or Indirect Authority 4

Percentage Of Ownership: Percentage Of Control: 20
Role: Board Member Other Role:
First Name: W Stephen Last Name: Harrington Suffix:
Gender: Male User Defined Gender:
What is this person's race or ethnicity?: White (German, Irish, English, Italian, Polish, French)
Specify Race or Ethnicity:

Person with Direct or Indirect Authority 5

Percentage Of Ownership: Percentage Of Control: 20
Role: Board Member Other Role:
First Name: Terence Last Name: Fracassa Suffix:
Gender: Male User Defined Gender:
What is this person's race or ethnicity?: White (German, Irish, English, Italian, Polish, French)
Specify Race or Ethnicity:

ENTITIES WITH DIRECT OR INDIRECT AUTHORITY

Entity with Direct or Indirect Authority 1

Percentage of Control: Percentage of Ownership: 73.46
Entity Legal Name: CanWell, LLC Entity DBA: DBA

Entity Description: Delaware Limited Liability Company

Foreign Subsidiary Narrative:

Entity Phone: 267-235-4906

Entity Email: stephen.harrington@canwell.us

Entity Website:

Entity Address 1: 117 Metro Center Blvd

Entity Address 2: Suite 2001

Entity City: Warwick

Entity State: RI

Entity Zip Code: 02886

Entity Mailing Address 1: 117 Metro Center Blvd

Entity Mailing Address 2: Suite 2001

Entity Mailing City: Warwick

Entity Mailing State: RI

Entity Mailing Zip Code: 02886

Relationship Description: Investment entity. Per the Restated Shareholders Agreement, CanWell LLC controls the right to appoint three of the five board members of the company. CanWell has currently appointed Terence Fracassa and W Stephen Harrington as directors of Liberty Compassion Inc., with the right to appoint a third board member if it so chooses.

Entity with Direct or Indirect Authority 2

Percentage of Control:

Percentage of Ownership:

Entity Legal Name: Edward Davis, LLC

Entity DBA: The Edward Davis Company

DBA

City:

Entity Description: Security Consultant

Foreign Subsidiary Narrative:

Entity Phone: 617-720-6250

Entity Email: mail@eddavisllc.com

Entity Website:

Entity Address 1: 2 Atlantic Avenue

Entity Address 2: 3rd Floor

Entity City: Boston

Entity State: MA

Entity Zip Code: 02110

Entity Mailing Address 1: 2 Atlantic Avenue

Entity Mailing Address 2: 3rd Floor

Entity Mailing City: Boston

Entity Mailing State: MA

Entity Mailing Zip Code:

02110

Relationship Description: The Edward Davis Company is the primary security vendor of Liberty Compassion, Inc and provides all security operations related services.

CLOSE ASSOCIATES AND MEMBERS

Close Associates or Member 1

First Name: Christine

Last Name: Cicon

Suffix:

Describe the nature of the relationship this person has with the Marijuana Establishment: Portfolio Operations for Canwell, LLC

Close Associates or Member 2

First Name: Jeremy

Last Name: Bromberg

Suffix:

Describe the nature of the relationship this person has with the Marijuana Establishment: Chief Operating Officer of CanWell, LLC

CAPITAL RESOURCES - INDIVIDUALS

No records found

CAPITAL RESOURCES - ENTITIES

Entity Contributing Capital 1

Entity Legal Name: Liberty Compassion, Inc.

Entity DBA:

Email: vgjordano@libertycentersusa.com

Phone: 401-273-8010

Address 1: 10 Greene Street

Address 2:

City: Providence

State: RI

Zip Code: 02903

Types of Capital: Monetary/Equity Other Type of Capital: Total Value of Capital Provided: \$1000000 Percentage of Initial Capital: 100

Capital Attestation: Yes

BUSINESS INTERESTS IN OTHER STATES OR COUNTRIES

Business Interest in Other State 1

Business Interest of an Owner or the Marijuana Establishment: Business Interest of an Owner

Owner First Name: CanWell, LLC

Owner Last Name:

Owner Suffix:

Entity Legal Name: Mobley Pain Management and Wellness Center (DE), LLC

Entity DBA:

Entity Description: Management Company that has loaned funds and receives consulting fees in exchange for services and expertise from Summit Medical Compassion Center, a state licensed medical marijuana compassion center in Warwick, RI (Non-Profit)

Entity Phone: 401-265-6262

Entity Email:

Entity Website:

stephen.harrington@canwell.us

Entity Address 1: 117 Metro Center Blvd

Entity Address 2: Ste 2001

Entity City: Warwick

Entity State: RI

Entity Zip Code: 02886

Entity Country: USA

Entity Mailing Address 1: 117 Metro Center Blvd

Entity Mailing Address 2: Ste 2001

Entity Mailing City: Warwick

Entity Mailing State: RI

Entity Mailing Zip Code:

Entity Mailing Country:

02886

USA

Business Interest in Other State 2

Business Interest of an Owner or the Marijuana Establishment: Business Interest of an Owner

Owner First Name: CanWell, LLC

Owner Last Name:

Owner Suffix:

Entity Legal Name: CanWell Processing (RI), LLC

Entity DBA:

Entity Description: Extraction Service Company that provides extraction services and consultation in exchange for royalties on alternative dosage sales by Summit Medical Compassion Center, a state licensed medical marijuana compassion center in Warwick, RI (Non-Profit)

Entity Phone: 401-265-6262

Entity Email:

Entity Website:

stephen.harrington@canwell.us

Entity Address 1: 117 Metro Center Blvd

Entity Address 2: Ste 2001

Entity City: Warwick

Entity State: RI

Entity Zip Code: 02886

Entity Country: USA

Entity Mailing Address 1: 117 Metro Center Blvd

Entity Mailing Address 2: Ste 2001

Entity Mailing City: Warwick

Entity Mailing State: RI

Entity Mailing Zip Code: 02886

Entity Mailing Country: USA

Business Interest in Other State 3

Business Interest of an Owner or the Marijuana Establishment: Business Interest of an Owner

Owner First Name: CanWell, LLC

Owner Last Name:

Owner Suffix:

Entity Legal Name: CanWell Processing (ME), LLC

Entity DBA:

Entity Description: Extraction Service Company that provides extraction services and consultation in exchange for royalties on alternative dosage sales by Wellness Connection of Maine, a state licensed marijuana company in Maine

Entity Phone: 401-265-6262

Entity Email:

Entity Website:

stephen.harrington@canwell.us

Entity Address 1: 117 Metro Center Blvd

Entity Address 2: Ste 2001

Entity City: Warwick

Entity State: RI

Entity Zip Code: 02886

Entity Country: USA

Entity Mailing Address 1: 117 Metro Center Blvd

Entity Mailing Address 2:

Entity Mailing City: Warwick

Entity Mailing State: RI

Entity Mailing Zip Code: 02886

Entity Mailing Country:

USA

Business Interest in Other State 4

Business Interest of an Owner or the Marijuana Establishment: Business Interest of an Owner

Owner First Name: CanWell, LLC Owner Last Name: Owner Suffix:
Entity Legal Name: Wellness Pain Management and Consulting, LLC Entity DBA:
Entity Description: Management Company that has loaned funds and receives consulting fees in exchange for services from Wellness Connection of Maine, a licensed marijuana company in Maine
Entity Phone: 863-738-4697 Entity Email: k.murphy@acreageholdings.com Entity Website:
Entity Address 1: 366 Madison Avenue Entity Address 2:
Entity City: New York Entity State: NY Entity Zip Code: 10017 Entity Country: USA
Entity Mailing Address 1: 200 Portland St Entity Mailing Address 2:
Entity Mailing City: Boston Entity Mailing State: MA Entity Mailing Zip Code: 02114 Entity Mailing Country: USA

DISCLOSURE OF INDIVIDUAL INTERESTS

Individual 1

First Name: Terence Last Name: Fracassa Suffix:
Marijuana Establishment Name: Nova Farms LLC Business Type: Marijuana Cultivator
Marijuana Establishment City: Attleboro Marijuana Establishment State: MA

Individual 2

First Name: W Stephen Last Name: Harrington Suffix:
Marijuana Establishment Name: Nova Farms LLC Business Type: Marijuana Cultivator
Marijuana Establishment City: Attleboro Marijuana Establishment State: MA

Individual 3

First Name: Terence Last Name: Fracassa Suffix:
Marijuana Establishment Name: Summit Medical Compassion Center Business Type: Marijuana Retailer
Marijuana Establishment City: Warwick Marijuana Establishment State: RI

MARIJUANA ESTABLISHMENT PROPERTY DETAILS

Establishment Address 1: 179 Brook Street
Establishment Address 2:
Establishment City: Clinton Establishment Zip Code: 01510
Approximate square footage of the Establishment: 62000 How many abutters does this property have?: 27
Have all property abutters have been notified of the intent to open a Marijuana Establishment at this address?: Yes
Cultivation Tier: Tier 02: 5,001 to 10,000 sq. ft. Cultivation Environment: Indoor

FEE QUESTIONS

Cultivation Tier: Tier 02: 5,001 to 10,000 sq. ft. Cultivation Environment: Indoor

HOST COMMUNITY INFORMATION

Host Community Documentation:

Document Category	Document Name	Type	ID	Upload Date
-------------------	---------------	------	----	-------------

Plan to Remain Compliant with Local Zoning	Plan to Remain Compliant with Local Zoning.pdf	pdf	5d8e2ca4d471f115eb598bf9	09/27/2019
Certification of Host Community Agreement	Liberty Compassion CCC Form_Clinton.pdf	pdf	5d96927008d9401ae68c6048	10/03/2019
Community Outreach Meeting Documentation	191219_Liberty Compassion community outreach meeting documentation RFI2.pdf	pdf	5dfbe774fe65bd5750701266	12/19/2019

Total amount of financial benefits accruing to the municipality as a result of the host community agreement. If the total amount is zero, please enter zero and provide documentation explaining this number.: \$

PLAN FOR POSITIVE IMPACT

Plan to Positively Impact Areas of Disproportionate Impact:

Document Category	Document Name	Type	ID	Upload Date
Other	Dismas House - Liberty letter 2019.jpg	jpeg	5d8e346cd471f115eb598c1b	09/27/2019
Plan for Positive Impact	Positive Impact Plan rev (1).pdf	pdf	5da7943bcdbfc22fc658b6ff	10/16/2019

ADDITIONAL INFORMATION NOTIFICATION

Notification: I Understand

INDIVIDUAL BACKGROUND INFORMATION

Individual Background Information 1

Role: Executive / Officer

Other Role:

First Name: Vincent

Last Name: Giordano Suffix:

RMD Association: RMD Owner

Background Question: no

Individual Background Information 2

Role: Manager

Other Role:

First Name: Christine

Last Name: Cicon Suffix:

RMD Association: RMD Staff

Background Question: no

Individual Background Information 3

Role: Executive / Officer

Other Role:

First Name: Jeremy

Last Name: Bromberg Suffix:

RMD Association: RMD Manager

Background Question: no

Individual Background Information 4

Role: Board Member

Other Role:

First Name: W Stephen

Last Name: Harrington Suffix:

RMD Association: RMD Owner

Background Question: no

Individual Background Information 5

Role: Board Member **Other Role:**
First Name: Terence **Last Name:** Fracassa **Suffix:**
RMD Association: RMD Owner
Background Question: yes

Individual Background Information 6

Role: Board Member **Other Role:**
First Name: Richard **Last Name:** Baccari **Suffix:**
RMD Association: RMD Owner
Background Question: yes

Individual Background Information 7

Role: Board Member **Other Role:**
First Name: Michael **Last Name:** Kent **Suffix:**
RMD Association: RMD Owner
Background Question: no

ENTITY BACKGROUND CHECK INFORMATION

Entity Background Check Information 1

Role: Other (specify) **Other Role:** Security Consultant
Entity Legal Name: Edward Davis, LLC **Entity DBA:** The Edward Davis Company
Entity Description: Primary security consultant
Phone: 617-720-6250 **Email:** mail@eddavisllc.com
Primary Business Address 1: 2 Atlantic Avenue **Primary Business Address 2:** 3rd Floor
Primary Business City: Boston **Primary Business State:** MA **Principal Business Zip Code:** 02110
Additional Information:

Entity Background Check Information 2

Role: Investor/Contributor **Other Role:**
Entity Legal Name: CanWell, LLC **Entity DBA:**
Entity Description: Delaware Limited Liability Company
Phone: 267-235-4906 **Email:** stephen.harrington@canwell.us
Primary Business Address 1: 117 Metro Center Blvd **Primary Business Address 2:** Suite 2001
Primary Business City: Warwick **Primary Business State:** RI **Principal Business Zip Code:** 02886
Additional Information:

MASSACHUSETTS BUSINESS REGISTRATION

Required Business Documentation:

Document Category	Document Name	Type	ID	Upload Date
Articles of Organization	Pages from Corporate Articles of Organization 1 of 2.pdf	pdf	5d51d1eb6614633871925bde	08/12/2019
Articles of Organization	Pages from Corporate Articles of Organization 2 of 2.pdf	pdf	5d51d1f954bcfa38af036b05	08/12/2019

Bylaws	Liberty Bylaws.pdf	pdf	5d6531e68470d4229ba43690	08/27/2019
Secretary of Commonwealth - Certificate of Good Standing	certificate of good standing State of MA.pdf	pdf	5d81103e32375f1de7f703c9	09/17/2019
Department of Revenue - Certificate of Good standing	MA DOR Cert of Good Standing.pdf	pdf	5db34d2f63788d2fee316677	10/25/2019

No documents uploaded

Massachusetts Business Identification Number: 001339605

Doing-Business-As Name:

DBA Registration City:

BUSINESS PLAN

Business Plan Documentation:

Document Category	Document Name	Type	ID	Upload Date
Business Plan	Liberty Compassion Business Plan.pdf	pdf	5d5eb3630473c3226f359cb2	08/22/2019
Plan for Liability Insurance	Plan to obtain liability insurance.pdf	pdf	5d5eb36a38be9e227ac51494	08/22/2019
Proposed Timeline	Liberty Compassion Timeline.pdf	pdf	5d7fead7271f0d1dcac33073	09/16/2019

OPERATING POLICIES AND PROCEDURES

Policies and Procedures Documentation:

Document Category	Document Name	Type	ID	Upload Date
Transportation of marijuana	7. Transportation of Marijuana.pdf	pdf	5d7fcfced4b61e1ddc08e9c5	09/16/2019
Restricting Access to age 21 and older	3. Restricting Access to Age 21 and Older.pdf	pdf	5d8f4e722e767115bf437123	09/28/2019
Storage of marijuana	6. Storage of Marijuana.pdf	pdf	5d8f53de67e7d91adfc66810	09/28/2019
Quality control and testing	9. Quality Control and Testing.pdf	pdf	5d8f59394e842f1b123baac4	09/28/2019
Personnel policies including background checks	11. Personnel Policies Including Background Checks.pdf	pdf	5d8fa039c1731c15b88f1fe2	09/28/2019
Maintaining of financial records	13. Maintaining of Financial Records.pdf	pdf	5d8fa20908d9401ae68c5140	09/28/2019
Qualifications and training	15. Qualifications and Training.pdf	pdf	5d8fa471d471f115eb598e20	09/28/2019
Security plan	4. Security Plan rev.pdf	pdf	5d9f2ce58d8d0715f66757df	10/10/2019
Inventory procedures	8. Inventory Procedures rev.pdf	pdf	5d9f3c6ac1731c15b88f3e9e	10/10/2019
Prevention of diversion	5. Prevention of Diversion rev.pdf	pdf	5d9f3dae1b7a141b1db84f45	10/10/2019
Record Keeping procedures	12. Record Keeping Procedures rev.pdf	pdf	5d9f402067e7d91adfc68805	10/10/2019
Policies and Procedures for cultivating.	1. Policies and Procedures for Cultivating rev.pdf	pdf	5d9f4870e87dc81b070014d6	10/10/2019
Diversity plan	Liberty Compassion Diversity Plan rev2.pdf	pdf	5e725e8bf0445c357cb03d15	03/18/2020

ATTESTATIONS

I certify that no additional entities or individuals meeting the requirement set forth in 935 CMR 500.101(1)(b)(1) or 935 CMR 500.101(2)(c)(1) have been omitted by the applicant from any marijuana establishment application(s) for licensure submitted to the Cannabis Control Commission.: I Agree

I understand that the regulations stated above require an applicant for licensure to list all executives, managers, persons or entities having direct or indirect authority over the management, policies, security operations or cultivation operations of the Marijuana Establishment; close associates and members of the applicant, if any; and a list of all persons or entities contributing 10% or more of the initial capital to operate the Marijuana Establishment including capital that is in the form of land or buildings.: I Agree

I certify that any entities who are required to be listed by the regulations above do not include any omitted individuals, who by themselves, would be required to be listed individually in any marijuana establishment application(s) for licensure submitted to the Cannabis Control Commission.: I Agree

Notification: I Understand

I certify that any changes in ownership or control, location, or name will be made pursuant to a separate process, as required under 935 CMR 500.104(1), and none of those changes have occurred in this application.:

I certify that to the best knowledge of any of the individuals listed within this application, there are no background events that have arisen since the issuance of the establishment's final license that would raise suitability issues in accordance with 935 CMR 500.801.:

I certify that all information contained within this renewal application is complete and true.:

ADDITIONAL INFORMATION NOTIFICATION

Notification: I Understand

COMPLIANCE WITH POSITIVE IMPACT PLAN

No records found

COMPLIANCE WITH DIVERSITY PLAN

No records found

HOURS OF OPERATION

Monday From: 7:00 AM	Monday To: 10:00 PM
Tuesday From: 7:00 AM	Tuesday To: 10:00 PM
Wednesday From: 7:00 AM	Wednesday To: 10:00 PM
Thursday From: 7:00 AM	Thursday To: 10:00 PM
Friday From: 7:00 AM	Friday To: 10:00 PM
Saturday From: 7:00 AM	Saturday To: 10:00 PM
Sunday From: 7:00 AM	Sunday To: 10:00 PM



Liberty Compassion

Dispensary
Boston, MA

Cultivation &
Product
Manufacturing
Clinton, MA

Dispensary
W. Springfield, MA

The Business Goal

Liberty Compassion is a vertically integrated medical and adult use marijuana cultivation, processing, and sales business in Massachusetts with a production facility in Clinton and potential dispensaries in Boston and West Springfield.

Our goal is to expand our business by adding an adult use cultivation and processing license in Clinton to sell into the whole sale MA market.

We are only seeking a cultivation and processing license. We currently do not have nor are we seeking for a dispensary license for our Clinton facility.

The Premise

A dramatic change in global attitudes has created a major market opportunity. We believe that Liberty is ideally situated to capture a significant portion of the available market in top locations as well as selling wholesale to the entire adult use market in MA.

Expanding market growing at an accelerated pace



Changing attitudes driving a paradigm shift



Securing coveted state/local licenses (after two years effort)



Efficient medical grade industrial production



Dispensaries in top markets and wholesale production

Industry Highlights

Growth In All Areas

- New markets
- State legislation
- All demographics
- Tax revenue
- Federal “comments” of support

Annual U.S. Cannabis Sales Vs. Other Industries & Goods

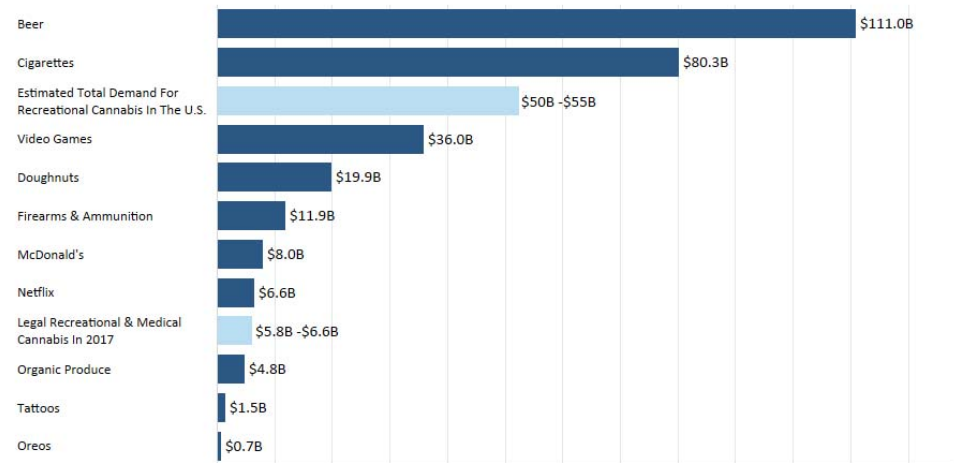

Source: Brewers Association, Alcohol & Tobacco Tax & Trade Bureau, Entertainment Software Association, Goldstein Research, IBIS World, Netflix, Nielsen, Nabisco
Copyright 2018 Marijuana Business Daily, a division of Anne Holland Ventures Inc. All rights reserved.

U.S. marijuana market projections through 2025

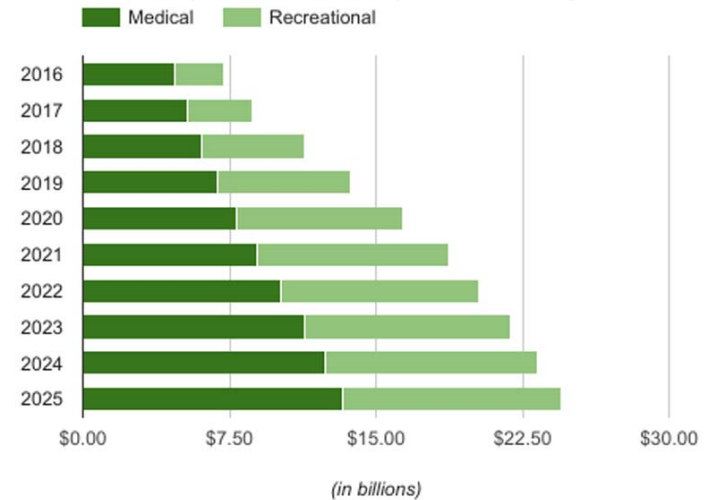

Our Market

- Centrally located grow operation
 - Clinton, MA
- Dispensary locations in most densely populated areas
 - Boston
 - W. Springfield

Production:

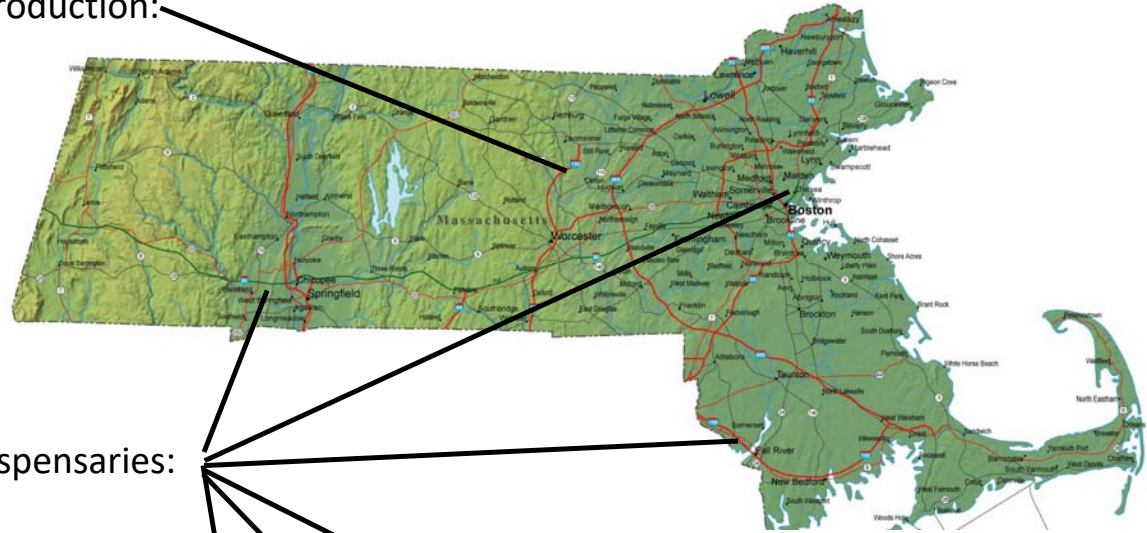

Dispensaries:

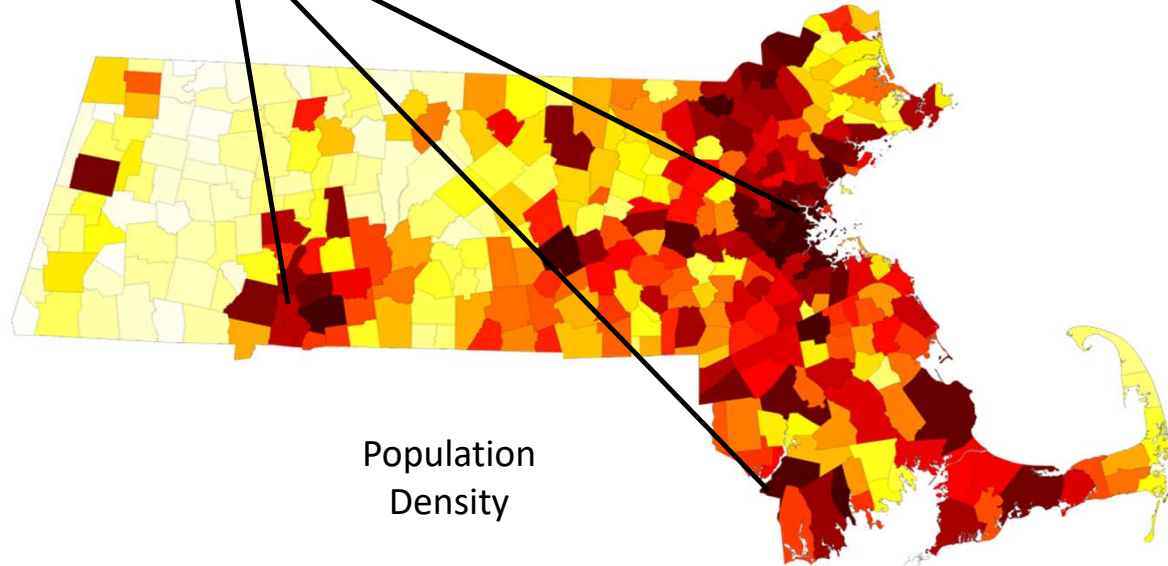

Population
Density

Extraction: The Future of Cannabis

- Closed loop process
- CO2 vs less safe alternatives
- Highest growth/High Margin
- Scales well
- Capital intensive
- Uses nearly 100% of plant
- Barrier to entry for small growers providing competitive advantage

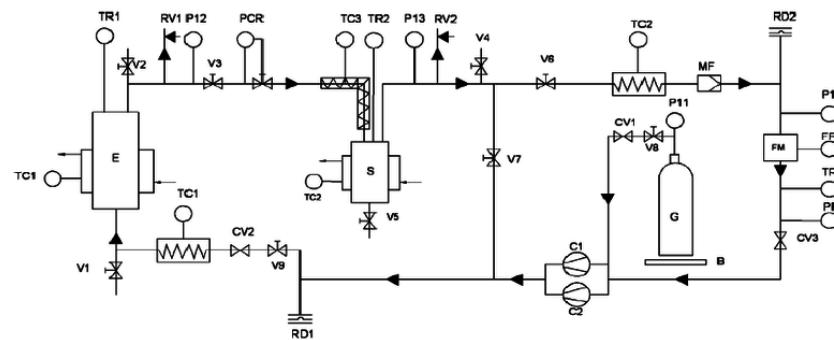
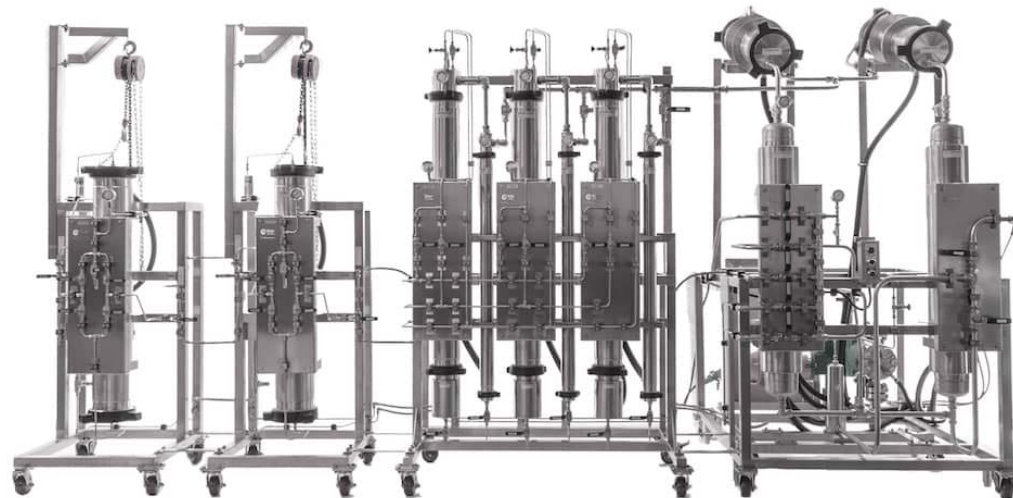

TC 1-3 : Heat exchangers	P 11-14 : Pressure indicators	FM : Flow meter	B : Balance
TR 1-3 : Temperature recorders	PCR: Pressure control regulator	G : Gas cylinder	E : Extractor
V 1-9 : Valves	RD 1-2: Rupture disc assemblies	CV 1-3 : Check valve assemblies	S : Separator
RV 1-2: Relief valve assemblies	MF: Micor filter	FR : Flow recorder	C 1-2 :Compressors
PR:Pressure recorder			

Expanding Our Market Opportunity

Bottom Up Market Analysis

- Revenue
- Average Sale
- Average visits per month
- Target Market
- % of local market captured
- Total local potential
- Total number of residents



Massachusetts

Potential Market: 7M people

Addressable Market: 700,000

Estimate of our target Medical: 24,000 people

Estimate of Adult Use Market Medical

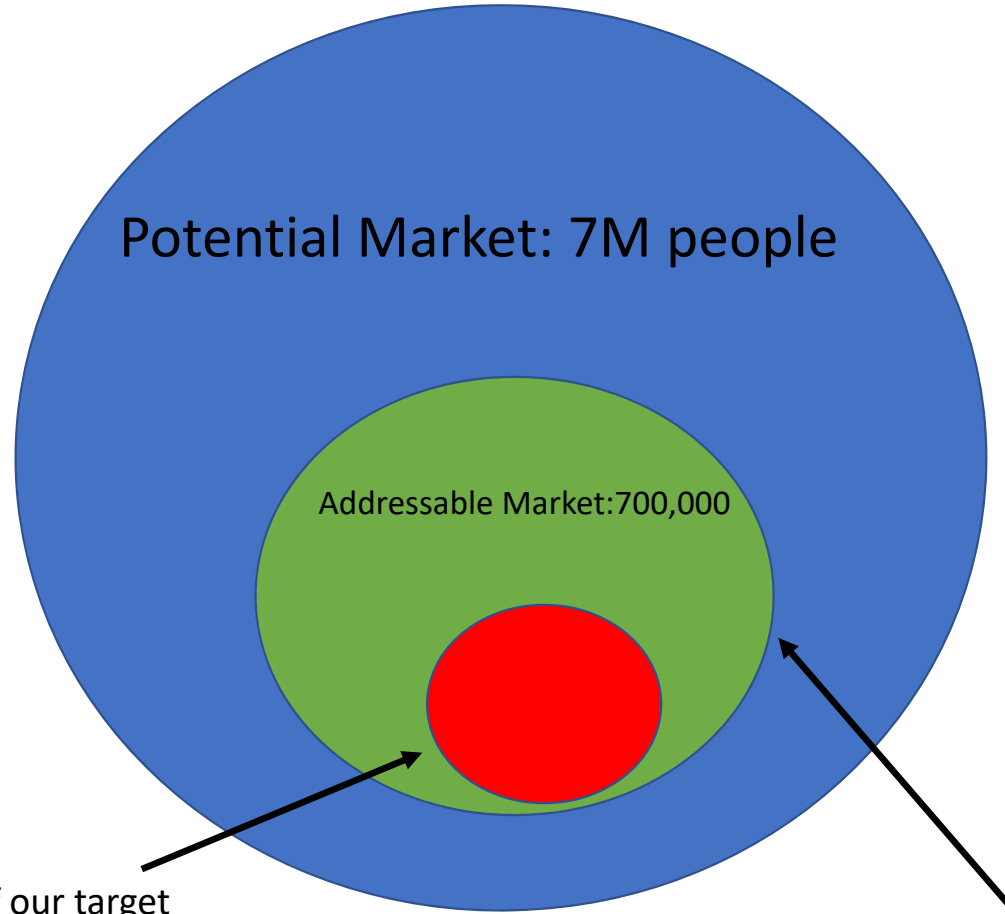

Revenue Projections

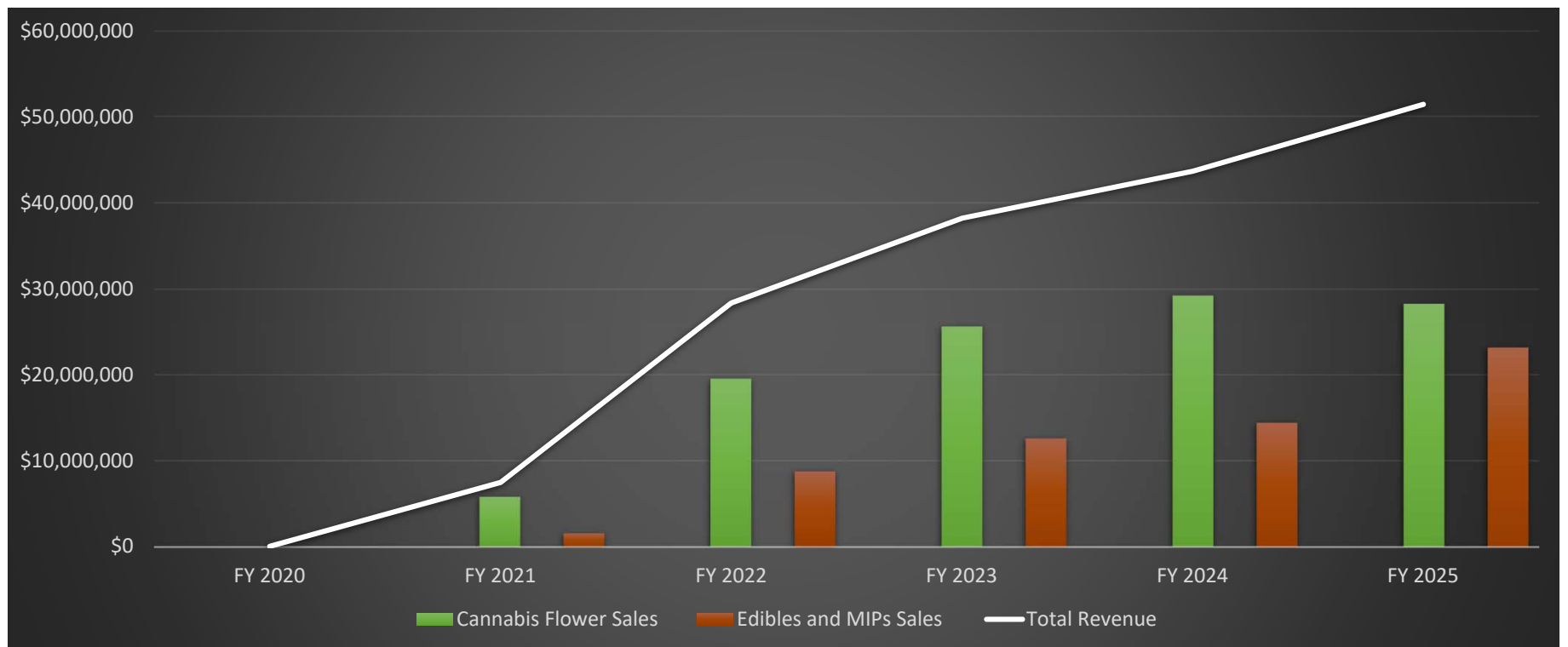

Product Mix

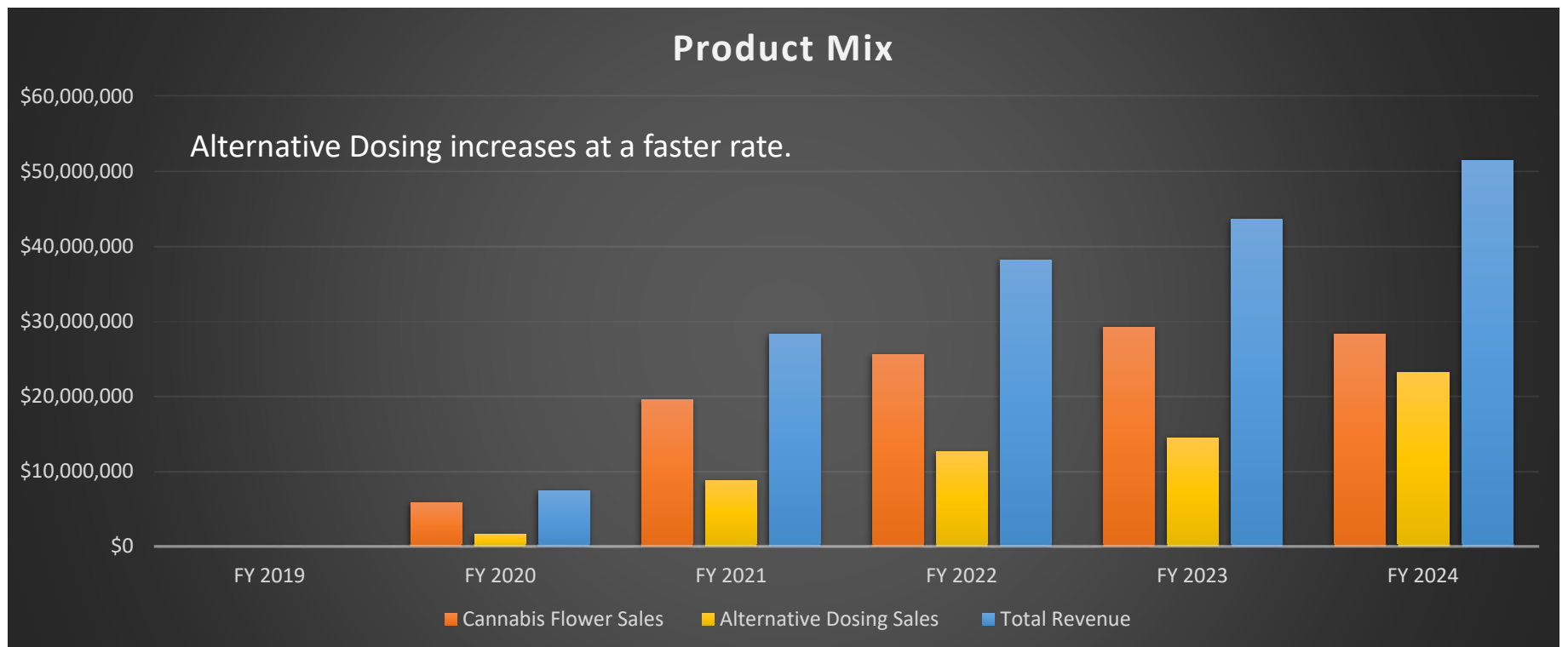

Time: Competitive Advantage

Liberty has a demonstrated track record of working with achieving a long-term positive relationship with state and local government as well as the local communities we operate in

State Application Submitted

State Application Approval

Location Siting Initiated

Production Facility Acquisition

City and Town Approvals

Production Facility Buildout

Dispensary Buildout

Production Facility Completed

First Grow Completed

Dispensaries Open



Opening a facility is a long term, complex process with substantial regulatory and political hurdles.

Adding adult use capacity will take advantage of our position and expand our market opportunity

Facility Highlights

- One of the largest sites in MA
- Pharmaceutical grade systems
- Commercial kitchens
- Pharma grade environmental and filtration systems
- Energy management systems
- Auxiliary power generation



Contact

Vincent Giordano

President

Liberty Compassion Centers

401-378-3087

vgiordano@libertycentersUSA.com

August 20, 2019

Jeremy Bromberg
Liberty Compassion, Inc.
179 Brook Street
Clinton, MA 01510

Dear Jeremy,

Per our discussions, The Hilb Group of NE, has agreed to procure on behalf of Liberty Compassion, Inc's insurance pursuant to the statutory requirements of 935 CMR 500.105(10). This includes, but not limited to the following:

- General Liability limits for no less than \$1,000,000 per occurrence/ \$2,000,000 aggregate. The deductible will be no higher than \$5,000 per occurrence.
- In addition to the statutory requirements, we will also be minimally obtaining the following coverages for Liberty Compassion
 - Property
 - Flood Insurance
 - Workers Compensation
 - Business Income Interruption
 - Automobile Coverage

If you have any questions, please let me know. I look forward to working with you.

Sincerely,

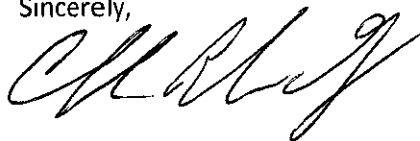

Ellen Bohn Gitlitz
Executive Vice President
502-342-6783
ebohn@hilbgroup.com

Host Community Agreement Certification Form

The applicant and contracting authority for the host community must complete each section of this form before uploading it to the application. Failure to complete a section will result in the application being deemed incomplete. Instructions to the applicant and/or municipality appear in italics. Please note that submission of information that is “misleading, incorrect, false, or fraudulent” is grounds for denial of an application for a license pursuant to 935 CMR 500.400(1).

Applicant

I, Vincent Giordano, (*insert name*) certify as an authorized representative of Liberty Compassion, Inc. (*insert name of applicant*) that the applicant has executed a host community agreement with Town of Clinton, Massachusetts (*insert name of host community*) pursuant to G.L.c. 94G § 3(d) on October 2, 2019 (*insert date*).

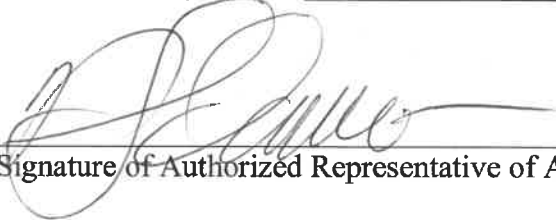
Signature of Authorized Representative of Applicant

Host Community

I, Michael J. Ward, (*insert name*) certify that I am the contracting authority or have been duly authorized by the contracting authority for Clinton Board of Selectmen (*insert name of host community*) to certify that the applicant and Town of Clinton, Massachusetts (*insert name of host community*) has executed a host community agreement pursuant to G.L.c. 94G § 3(d) on October 2, 2019 (*insert date*).

Signature of Contracting Authority or
Authorized Representative of Host Community

Community Outreach Meeting Attestation Form

The applicant must complete each section of this form and initial each page before uploading it to the application. Failure to complete a section will result in the application being deemed incomplete. Instructions to the applicant appear in italics. Please note that submission of information that is "misleading, incorrect, false, or fraudulent" is grounds for denial of an application for a license pursuant to 935 CMR 500.400(1).

I, Vincent Giordano, (insert name) attest as an authorized representative of Wendy Compton (insert name of applicant) that the applicant has complied with the requirements of 935 CMR 500 and the guidance for licensed applicants on community outreach, as detailed below.

1. The Community Outreach Meeting was held on 12/18/2019 (insert date).
2. A copy of a notice of the time, place, and subject matter of the meeting, including the proposed address of the Marijuana Establishment, was published in a newspaper of general circulation in the city or town on 12/10/2019 (insert date), which was at least seven calendar days prior to the meeting. A copy of the newspaper notice is attached as Attachment A (please clearly label the newspaper notice in the upper right hand corner as Attachment A and upload it as part of this document).
3. A copy of the meeting notice was also filed on 12/10/2019 (insert date) with the city or town clerk, the planning board, the contracting authority for the municipality, and local licensing authority for the adult use of marijuana, if applicable. A copy of the municipal notice is attached as Attachment B (please clearly label the municipal notice in the upper right-hand corner as Attachment B and upload it as part of this document).
4. Notice of the time, place and subject matter of the meeting, including the proposed address of the Marijuana Establishment, was mailed on 12/11/2019 (insert date), which was at least seven calendar days prior to the community outreach meeting to abutters of the proposed address of the Marijuana Establishment, and residents within 300 feet of the property line of the petitioner as they appear on the most recent applicable tax list, notwithstanding that the land of any such owner is located in another city or town. A copy of one of the notices sent to abutters and parties of interest as described in this section is attached as Attachment C (please clearly label the municipal notice in the upper right hand corner as Attachment C and upload it as part of this document; please only include a copy of one notice and please black out the name and the address of the addressee).

5. Information was presented at the community outreach meeting including:
 - a. The type(s) of Marijuana Establishment to be located at the proposed address;
 - b. Information adequate to demonstrate that the location will be maintained securely;
 - c. Steps to be taken by the Marijuana Establishment to prevent diversion to minors;
 - d. A plan by the Marijuana Establishment to positively impact the community; and
 - e. Information adequate to demonstrate that the location will not constitute a nuisance as defined by law.

6. Community members were permitted to ask questions and receive answers from representatives of the Marijuana Establishment.

ROOMS FOR RENT

Worcester 3 rooms. Worcester Clark Ave 125 weeks. Refrigerator and sink on each room. Newly furnished. (508) 754-0097.

WORCESTER FURNISHED 1 person only. Low rent, 4.99K. quiet location. Security to cable TV. Ref. CORL 509-799-7975

LEGAL NOTICES

NOTICE OF MORTGAGEE'S SALE OF REAL ESTATE. Premises: 11 Whipple Street, Worcester, MA 01607. By virtue of an execution of the Power of Sale contained in a certain mortgage given by Daniel A. Conner...

THE LAND WITH THE BUILDINGS THEREON IN WORCESTER, MASSACHUSETTS, BEING 1000 MAIN STREET AND THE WESTERN 1/2 OF THE SOUTHERLY 1/2 OF MAPLE STREET AND THE SOUTHERLY 1/2 OF MAPLE STREET AND THE SOUTHERLY 1/2 OF MAPLE STREET AND THE SOUTHERLY 1/2 OF MAPLE STREET...

THENCE SOUTHERLY BY SAID MAINE'S LAND, ONE AND ONE-HALF FEET TO A POINT OF BEGINNING; THENCE WESTERLY FIFTY-FOOT AND ONE-FOURTH (50'-03/4) FEET TO A POINT OF BEGINNING; THENCE NORTHERLY ONE HUNDRED AND THIRTY-ONE (131) FEET TO THE SOUTHERLY CORNER OF SAID SOUTH STREET...

THENCE SOUTHERLY BY SAID STREET FIFTY-FOOT (50) FEET TO THE PLACE OF THE BEGINNING. THENCE WESTERLY ONE HUNDRED AND THIRTY-ONE (131) FEET TO THE SOUTHERLY CORNER OF SAID SOUTH STREET...

THENCE WESTERLY BY SAID STREET FIFTY-FOOT (50) FEET TO THE PLACE OF THE BEGINNING. THENCE NORTHERLY ONE HUNDRED AND THIRTY-ONE (131) FEET TO THE SOUTHERLY CORNER OF SAID SOUTH STREET...

THENCE WESTERLY BY SAID STREET FIFTY-FOOT (50) FEET TO THE PLACE OF THE BEGINNING. THENCE NORTHERLY ONE HUNDRED AND THIRTY-ONE (131) FEET TO THE SOUTHERLY CORNER OF SAID SOUTH STREET...

THENCE WESTERLY BY SAID STREET FIFTY-FOOT (50) FEET TO THE PLACE OF THE BEGINNING. THENCE NORTHERLY ONE HUNDRED AND THIRTY-ONE (131) FEET TO THE SOUTHERLY CORNER OF SAID SOUTH STREET...

THENCE WESTERLY BY SAID STREET FIFTY-FOOT (50) FEET TO THE PLACE OF THE BEGINNING. THENCE NORTHERLY ONE HUNDRED AND THIRTY-ONE (131) FEET TO THE SOUTHERLY CORNER OF SAID SOUTH STREET...

THENCE WESTERLY BY SAID STREET FIFTY-FOOT (50) FEET TO THE PLACE OF THE BEGINNING. THENCE NORTHERLY ONE HUNDRED AND THIRTY-ONE (131) FEET TO THE SOUTHERLY CORNER OF SAID SOUTH STREET...

THENCE WESTERLY BY SAID STREET FIFTY-FOOT (50) FEET TO THE PLACE OF THE BEGINNING. THENCE NORTHERLY ONE HUNDRED AND THIRTY-ONE (131) FEET TO THE SOUTHERLY CORNER OF SAID SOUTH STREET...

THENCE WESTERLY BY SAID STREET FIFTY-FOOT (50) FEET TO THE PLACE OF THE BEGINNING. THENCE NORTHERLY ONE HUNDRED AND THIRTY-ONE (131) FEET TO THE SOUTHERLY CORNER OF SAID SOUTH STREET...

THENCE WESTERLY BY SAID STREET FIFTY-FOOT (50) FEET TO THE PLACE OF THE BEGINNING. THENCE NORTHERLY ONE HUNDRED AND THIRTY-ONE (131) FEET TO THE SOUTHERLY CORNER OF SAID SOUTH STREET...

THENCE WESTERLY BY SAID STREET FIFTY-FOOT (50) FEET TO THE PLACE OF THE BEGINNING. THENCE NORTHERLY ONE HUNDRED AND THIRTY-ONE (131) FEET TO THE SOUTHERLY CORNER OF SAID SOUTH STREET...

THENCE WESTERLY BY SAID STREET FIFTY-FOOT (50) FEET TO THE PLACE OF THE BEGINNING. THENCE NORTHERLY ONE HUNDRED AND THIRTY-ONE (131) FEET TO THE SOUTHERLY CORNER OF SAID SOUTH STREET...

THENCE WESTERLY BY SAID STREET FIFTY-FOOT (50) FEET TO THE PLACE OF THE BEGINNING. THENCE NORTHERLY ONE HUNDRED AND THIRTY-ONE (131) FEET TO THE SOUTHERLY CORNER OF SAID SOUTH STREET...

THENCE WESTERLY BY SAID STREET FIFTY-FOOT (50) FEET TO THE PLACE OF THE BEGINNING. THENCE NORTHERLY ONE HUNDRED AND THIRTY-ONE (131) FEET TO THE SOUTHERLY CORNER OF SAID SOUTH STREET...

LEGAL NOTICES

LEGAL COMMONWEALTH OF MASSACHUSETTS LAND COURT. DEPARTMENT OF THE TRIAL COURT. ORDER OF NOTICE. 19-50 00822

TO: Heidi Piana and Heidi Grace Anderson; Clarence C. Holland Jr. In accordance with the provisions of the Massachusetts Land Court Act, 90A U.S.C. 50 § 1-3, I, the undersigned, Clerk of the said Land Court, do hereby give notice to the said parties...

TO: Wm. Gordon H. Piper Chief Justice of said Court on November 26, 2019. Attest: Deborah J. Peterson, Recorder, December 10, 2019.

LEGAL COMMONWEALTH OF MASSACHUSETTS LAND COURT. DEPARTMENT OF THE TRIAL COURT. ORDER OF NOTICE. 19-50 00860

TO: Wm. Gordon H. Piper Chief Justice of said Court on November 26, 2019. Attest: Deborah J. Peterson, Recorder, December 10, 2019.

LEGAL COMMONWEALTH OF MASSACHUSETTS LAND COURT. DEPARTMENT OF THE TRIAL COURT. ORDER OF NOTICE. 19-50 00866

TO: Wm. Gordon H. Piper Chief Justice of said Court on November 26, 2019. Attest: Deborah J. Peterson, Recorder, December 10, 2019.

LEGAL COMMONWEALTH OF MASSACHUSETTS LAND COURT. DEPARTMENT OF THE TRIAL COURT. ORDER OF NOTICE. 19-50 00872

TO: Wm. Gordon H. Piper Chief Justice of said Court on November 26, 2019. Attest: Deborah J. Peterson, Recorder, December 10, 2019.

LEGAL COMMONWEALTH OF MASSACHUSETTS LAND COURT. DEPARTMENT OF THE TRIAL COURT. ORDER OF NOTICE. 19-50 00921

TO: Wm. Gordon H. Piper Chief Justice of said Court on November 26, 2019. Attest: Deborah J. Peterson, Recorder, December 10, 2019.

COMMUNWEALTH OF MASSACHUSETTS Probate and Family Court. Docket No. W019C0870CA

Worcester Probate and Family Court. 225 Main Street, Worcester, MA 01608. CITATION ON PETITION TO CHANGE NAME

In the matter of: Sheila Beartz Carrazzillo. A petition to change name of Adult has been filed by Sheila Beartz Carrazzillo, of Worcester, MA, requesting that the court enter a Decree changing her name to...

WITNESSE, Hon. Leilah A. Keamy, First Justice of said Court. Date: November 26, 2019. Attest: Deborah J. Peterson, Recorder, December 10, 2019.

COMMUNWEALTH OF MASSACHUSETTS Probate and Family Court. Docket No. W019C0870CA

Worcester Probate and Family Court. 225 Main Street, Worcester, MA 01608. CITATION ON PETITION TO CHANGE NAME

In the matter of: Sheila Beartz Carrazzillo. A petition to change name of Adult has been filed by Sheila Beartz Carrazzillo, of Worcester, MA, requesting that the court enter a Decree changing her name to...

WITNESSE, Hon. Leilah A. Keamy, First Justice of said Court. Date: November 26, 2019. Attest: Deborah J. Peterson, Recorder, December 10, 2019.

DEAR ANNIE

Harkening back to less hardware

By Annie Lane. Dear Annie: I am the proud owner of a flip cellphone, and I probably wouldn't have it if public telephones still existed. I use about 100 minutes a month and have sent, in my lifetime, no more than 300 text messages, most of them one or two words in response to a text sent to me. I use no data. I still use physical maps to navigate car trips.

However, I use a computer at my job for most of the day, so it's not like I'm a Luddite. But I say all this because I notice an increasing separation between myself and most of the rest of society, regarding my phone use. My wife has a smartphone and is on it frequently. I wouldn't say she's on it too much, at least compared to a lot of other smartphone users.

She has hobbies besides her phone, but I've noticed that the phone eats up more of her time than consumer technologies did years ago. I notice, too, when I go to parks with my kids or take them to swimming lessons or soccer practice that many parents sit there looking at their phones. And I just shake my head, shocked at how quickly everything has changed in a mere 10 years or so. I'm curious if any of your readers are troubled by these trends? — Doubtless Computer

Dear Doubtless Computer: Thank you for your letter. You raise a very important conversation. On the one hand, technology is absolutely amazing and has helped our society in so many ways. But it can also be dangerous when used too much. Social connections, face to face, are the healthiest form of connections. Being able to really see another person is a gift that we can all give to each other. That gift is often lost because of texting or other forms of social media. I think you might be onto something that people are increasingly wishing for the good of: being with us were not bombarded with a constant blue light glow. On the one hand, screens have reduced boredom; there's always something to see, read or watch. On the other hand, they have taken away boredom, which can become a space where creativity and imagination bloom.

Send your questions for Annie Lane to dearannie@creators.com. Social connections, face to face, are the healthiest form of connections. Being able to really see another person is a gift that we can all give to each other. That gift is often lost because of texting or other forms of social media. I think you might be onto something that people are increasingly wishing for the good of: being with us were not bombarded with a constant blue light glow. On the one hand, screens have reduced boredom; there's always something to see, read or watch. On the other hand, they have taken away boredom, which can become a space where creativity and imagination bloom.

Send your questions for Annie Lane to dearannie@creators.com. Social connections, face to face, are the healthiest form of connections. Being able to really see another person is a gift that we can all give to each other. That gift is often lost because of texting or other forms of social media. I think you might be onto something that people are increasingly wishing for the good of: being with us were not bombarded with a constant blue light glow. On the one hand, screens have reduced boredom; there's always something to see, read or watch. On the other hand, they have taken away boredom, which can become a space where creativity and imagination bloom.

Send your questions for Annie Lane to dearannie@creators.com. Social connections, face to face, are the healthiest form of connections. Being able to really see another person is a gift that we can all give to each other. That gift is often lost because of texting or other forms of social media. I think you might be onto something that people are increasingly wishing for the good of: being with us were not bombarded with a constant blue light glow. On the one hand, screens have reduced boredom; there's always something to see, read or watch. On the other hand, they have taken away boredom, which can become a space where creativity and imagination bloom.

Send your questions for Annie Lane to dearannie@creators.com. Social connections, face to face, are the healthiest form of connections. Being able to really see another person is a gift that we can all give to each other. That gift is often lost because of texting or other forms of social media. I think you might be onto something that people are increasingly wishing for the good of: being with us were not bombarded with a constant blue light glow. On the one hand, screens have reduced boredom; there's always something to see, read or watch. On the other hand, they have taken away boredom, which can become a space where creativity and imagination bloom.

Send your questions for Annie Lane to dearannie@creators.com. Social connections, face to face, are the healthiest form of connections. Being able to really see another person is a gift that we can all give to each other. That gift is often lost because of texting or other forms of social media. I think you might be onto something that people are increasingly wishing for the good of: being with us were not bombarded with a constant blue light glow. On the one hand, screens have reduced boredom; there's always something to see, read or watch. On the other hand, they have taken away boredom, which can become a space where creativity and imagination bloom.

DEAR ANNIE

Harkening back to less hardware

By Annie Lane. Dear Annie: I am the proud owner of a flip cellphone, and I probably wouldn't have it if public telephones still existed. I use about 100 minutes a month and have sent, in my lifetime, no more than 300 text messages, most of them one or two words in response to a text sent to me. I use no data. I still use physical maps to navigate car trips.

However, I use a computer at my job for most of the day, so it's not like I'm a Luddite. But I say all this because I notice an increasing separation between myself and most of the rest of society, regarding my phone use. My wife has a smartphone and is on it frequently. I wouldn't say she's on it too much, at least compared to a lot of other smartphone users.

She has hobbies besides her phone, but I've noticed that the phone eats up more of her time than consumer technologies did years ago. I notice, too, when I go to parks with my kids or take them to swimming lessons or soccer practice that many parents sit there looking at their phones. And I just shake my head, shocked at how quickly everything has changed in a mere 10 years or so. I'm curious if any of your readers are troubled by these trends? — Doubtless Computer

Dear Doubtless Computer: Thank you for your letter. You raise a very important conversation. On the one hand, technology is absolutely amazing and has helped our society in so many ways. But it can also be dangerous when used too much. Social connections, face to face, are the healthiest form of connections. Being able to really see another person is a gift that we can all give to each other. That gift is often lost because of texting or other forms of social media. I think you might be onto something that people are increasingly wishing for the good of: being with us were not bombarded with a constant blue light glow. On the one hand, screens have reduced boredom; there's always something to see, read or watch. On the other hand, they have taken away boredom, which can become a space where creativity and imagination bloom.

Send your questions for Annie Lane to dearannie@creators.com. Social connections, face to face, are the healthiest form of connections. Being able to really see another person is a gift that we can all give to each other. That gift is often lost because of texting or other forms of social media. I think you might be onto something that people are increasingly wishing for the good of: being with us were not bombarded with a constant blue light glow. On the one hand, screens have reduced boredom; there's always something to see, read or watch. On the other hand, they have taken away boredom, which can become a space where creativity and imagination bloom.

Send your questions for Annie Lane to dearannie@creators.com. Social connections, face to face, are the healthiest form of connections. Being able to really see another person is a gift that we can all give to each other. That gift is often lost because of texting or other forms of social media. I think you might be onto something that people are increasingly wishing for the good of: being with us were not bombarded with a constant blue light glow. On the one hand, screens have reduced boredom; there's always something to see, read or watch. On the other hand, they have taken away boredom, which can become a space where creativity and imagination bloom.

Send your questions for Annie Lane to dearannie@creators.com. Social connections, face to face, are the healthiest form of connections. Being able to really see another person is a gift that we can all give to each other. That gift is often lost because of texting or other forms of social media. I think you might be onto something that people are increasingly wishing for the good of: being with us were not bombarded with a constant blue light glow. On the one hand, screens have reduced boredom; there's always something to see, read or watch. On the other hand, they have taken away boredom, which can become a space where creativity and imagination bloom.

Send your questions for Annie Lane to dearannie@creators.com. Social connections, face to face, are the healthiest form of connections. Being able to really see another person is a gift that we can all give to each other. That gift is often lost because of texting or other forms of social media. I think you might be onto something that people are increasingly wishing for the good of: being with us were not bombarded with a constant blue light glow. On the one hand, screens have reduced boredom; there's always something to see, read or watch. On the other hand, they have taken away boredom, which can become a space where creativity and imagination bloom.

Send your questions for Annie Lane to dearannie@creators.com. Social connections, face to face, are the healthiest form of connections. Being able to really see another person is a gift that we can all give to each other. That gift is often lost because of texting or other forms of social media. I think you might be onto something that people are increasingly wishing for the good of: being with us were not bombarded with a constant blue light glow. On the one hand, screens have reduced boredom; there's always something to see, read or watch. On the other hand, they have taken away boredom, which can become a space where creativity and imagination bloom.

MARKETPLACE

LOST & FOUND PETS. REWARD \$50 for Lost Dalmatian German cat. 508-754-0097.

CHIMNEY CLEANING. ONLY 99¢ Quality Chimney any 1 fire chimney. 508-754-0097.

COAL, WOOD & OIL. Cleanwood seasoned hardwood cut and split. 508-754-0097.

ELECTRICIANS. PAUL PALIBRO Electric Master Electrician. 508-754-0097.

MISCELLANEOUS. LOW COST SNAVER Program at Clinton Veterinary Services. 508-754-0097.

WANTED. WANTED - CASH PAID - ANTIQUES OLD. 508-754-0097.

FOUNDATIONS. FOUNDATION Concrete All kinds Waterproofing. 508-754-0097.

CHIMNEY CLEANING. ONLY 99¢ Quality Chimney any 1 fire chimney. 508-754-0097.

COAL, WOOD & OIL. Cleanwood seasoned hardwood cut and split. 508-754-0097.

ELECTRICIANS. PAUL PALIBRO Electric Master Electrician. 508-754-0097.

MISCELLANEOUS. LOW COST SNAVER Program at Clinton Veterinary Services. 508-754-0097.

WANTED. WANTED - CASH PAID - ANTIQUES OLD. 508-754-0097.

FOUNDATIONS. FOUNDATION Concrete All kinds Waterproofing. 508-754-0097.

FOUNDATIONS. FOUNDATION Concrete All kinds Waterproofing. 508-754-0097.

FOUNDATIONS. FOUNDATION Concrete All kinds Waterproofing. 508-754-0097.

FOUNDATIONS. FOUNDATION Concrete All kinds Waterproofing. 508-754-0097.

FOUNDATIONS. FOUNDATION Concrete All kinds Waterproofing. 508-754-0097.

FOUNDATIONS. FOUNDATION Concrete All kinds Waterproofing. 508-754-0097.

FOUNDATIONS. FOUNDATION Concrete All kinds Waterproofing. 508-754-0097.

FOUNDATIONS. FOUNDATION Concrete All kinds Waterproofing. 508-754-0097.

FOUNDATIONS. FOUNDATION Concrete All kinds Waterproofing. 508-754-0097.

CHIMNEY CLEANING. ONLY 99¢ Quality Chimney any 1 fire chimney. 508-754-0097.

COAL, WOOD & OIL. Cleanwood seasoned hardwood cut and split. 508-754-0097.

ELECTRICIANS. PAUL PALIBRO Electric Master Electrician. 508-754-0097.

MISCELLANEOUS. LOW COST SNAVER Program at Clinton Veterinary Services. 508-754-0097.

WANTED. WANTED - CASH PAID - ANTIQUES OLD. 508-754-0097.

FOUNDATIONS. FOUNDATION Concrete All kinds Waterproofing. 508-754-0097.

FOUNDATIONS. FOUNDATION Concrete All kinds Waterproofing. 508-754-0097.

FOUNDATIONS. FOUNDATION Concrete All kinds Waterproofing. 508-754-0097.

FOUNDATIONS. FOUNDATION Concrete All kinds Waterproofing. 508-754-0097.

FOUNDATIONS. FOUNDATION Concrete All kinds Waterproofing. 508-754-0097.

FOUNDATIONS. FOUNDATION Concrete All kinds Waterproofing. 508-754-0097.

FOUNDATIONS. FOUNDATION Concrete All kinds Waterproofing. 508-754-0097.

FOUNDATIONS. FOUNDATION Concrete All kinds Waterproofing. 508-754-0097.

FOUNDATIONS. FOUNDATION Concrete All kinds Waterproofing. 508-754-0097.

CHIMNEY CLEANING. ONLY 99¢ Quality Chimney any 1 fire chimney. 508-754-0097.

COAL, WOOD & OIL. Cleanwood seasoned hardwood cut and split. 508-754-0097.

ELECTRICIANS. PAUL PALIBRO Electric Master Electrician. 508-754-0097.

MISCELLANEOUS. LOW COST SNAVER Program at Clinton Veterinary Services. 508-754-0097.

WANTED. WANTED - CASH PAID - ANTIQUES OLD. 508-754-0097.

FOUNDATIONS. FOUNDATION Concrete All kinds Waterproofing. 508-754-0097.

FOUNDATIONS. FOUNDATION Concrete All kinds Waterproofing. 508-754-0097.

FOUNDATIONS. FOUNDATION Concrete All kinds Waterproofing. 508-754-0097.

FOUNDATIONS. FOUNDATION Concrete All kinds Waterproofing. 508-754-0097.

FOUNDATIONS. FOUNDATION Concrete All kinds Waterproofing. 508-754-0097.

FOUNDATIONS. FOUNDATION Concrete All kinds Waterproofing. 508-754-0097.

FOUNDATIONS. FOUNDATION Concrete All kinds Waterproofing. 508-754-0097.

FOUNDATIONS. FOUNDATION Concrete All kinds Waterproofing. 508-754-0097.

FOUNDATIONS. FOUNDATION Concrete All kinds Waterproofing. 508-754-0097.

SUDOKU

Concepts Sudoku grid by Dave Green. Grid with numbers 1-9 and empty cells.

Answers for Sudoku & Kenken appear on B7

KENKEN

Kenken puzzle grid with numbers and arithmetic symbols.

Kenken is a number puzzle that involves a bit of logic and a bit of simple math.

BRIDGE

In the round robin match between Denmark and Italy at the 199 World Junior Teams in Fort Lauderdale, Florida, a textbook hand in suit-preference signaling came along. Unusually, the hand on lead making the suit-preference signal wasn't giving the ruff, but paving the way for the ruff.

Morten Madsen of Denmark as East thought long and hard before pushing his opponents with his call of two spades — and rightly so. The defense had seven tricks against that contract, but when North doubled a second time just to show cards, South decided against trying to take the penalty. You could certainly argue that, with a balanced hand and reasonable defense, it was more

sensible to pass here, but at teams, players are often reluctant to sit for the double of a part-score into game. The opening lead of the spade queen held the trick. Now Kaspar Know (West) deliberately set up dummy's spade 10 by leading a suit-preference jack at the second trick, since he knew that his partner's delayed support was likely to be based on exactly a doubleton spade. Hence, he had to prepare the way for a spade ruff.

Madsen won his ace-ace force and duly led a diamond (the higher of the minor suits) in order to ensure the ruff. There was still the diamond queen coming to the defense for the setting trick. Notice that if East plays a club after winning his spade ace, declarer gets in to draw trumps at once, and the defenders lose their ruff.

HOROSCOPES

Happy Birthdays: Your emotions will be difficult to dismiss. You'll feel more inclined to say what's on your mind and question anyone who is vague or appears to be playing games with you. Gather your thoughts methodically and venture down a path that feels right and shows promise. Your numbers are 7, 12, 18, 22, 37, 43.

ARIES (March 21-April 19): Take care of matters personally. The only way to get things done the way you want is to do them yourself. Someone will disappoint you or leave you in a vulnerable position.

TAURUS (April 20-May 20): Make changes that will bring you closer to someone you love. A day trip, educational pursuit or opportunity to get involved in something unique looks inviting.

GEMINI (May 21-June 20): Emotions will be raised, and what you say will matter. Choose your words wisely, be precise and follow through with any promises you make. Ask questions if someone evades issues or tries to confuse you. Reveal only what's necessary.

DEAR ANNIE

Harkening back to less hardware

By Annie Lane. Dear Annie: I am the proud owner of a flip cellphone, and I probably wouldn't have it if public telephones still existed. I use about 100 minutes a month and have sent, in my lifetime, no more than 300 text messages, most of them one or two words in response to a text sent to me. I use no data. I still use physical maps to navigate car trips.

However, I use a computer at my job for most of the day, so it's not like I'm a Luddite. But I say all this because I notice an increasing separation between myself and most of the rest of society, regarding my phone use. My wife has a smartphone and is on it frequently. I wouldn't say she's on it too much, at least compared to a lot of other smartphone users.

She has hobbies besides her phone, but I've noticed that the phone eats up more of her time than consumer technologies did years ago. I notice, too, when I go to parks with my kids or take them to swimming lessons or soccer practice that many parents sit there looking at their phones. And I just shake my head, shocked at how quickly everything has changed in a mere 10 years or so. I'm curious if any of your readers are troubled by these trends? — Doubtless Computer

Dear Doubtless Computer: Thank you for your letter. You raise a very important conversation. On the one hand, technology is absolutely amazing and has helped our society in so many ways. But it can also be dangerous when used too much. Social connections, face to face, are the healthiest form of connections. Being able to really see another person is a gift that we can all give to each other. That gift is often lost because of texting or other forms of social media. I think you might be onto something that people are increasingly wishing for the good of: being with us were not bombarded with a constant blue light glow. On the one hand, screens have reduced boredom; there's always something to see, read or watch. On the other hand, they have taken away boredom, which can become a space where creativity and imagination bloom.

Send your questions for Annie Lane to dearannie@creators.com. Social connections, face to face, are the healthiest form of connections. Being able to really see another person is a gift that we can all give to each other. That gift is often lost because of texting or other forms of social media. I think you might be onto something that people are increasingly wishing for the good of: being with us were not bombarded with a constant blue light glow. On the one hand, screens have reduced boredom; there's always something to see, read or watch. On the other hand, they have taken away boredom, which can become a space where creativity and imagination bloom.

November 26, 2019

Notice of Public Meeting

Notice is hereby given that a Community Outreach Meeting for a Proposed Cannabis Cultivation and Processing Establishment is scheduled for:

Date: 18 December, 2019

Time: 6:00PM

Location: Clinton Senior Center

271 Church Street

Clinton, MA 01510

The Proposed Cultivator and Product Manufacturer Marijuana Establishment is anticipated to be located at:

179 Brook Street

Clinton, MA 01510

This meeting will contain the same information that was presented at the public meeting on August 26, 2019. There will be an opportunity for the public to ask additional questions.

December 10, 2019

Notice of Public Meeting

Notice is hereby given that a Community Outreach Meeting for a Proposed Cannabis Cultivation and Processing Establishment is scheduled for:

Date: 18 December, 2019

Time: 6:00PM

Location: Clinton Senior Center

271 Church Street

Clinton, MA 01510

The Proposed Cultivator and Product Manufacturer Marijuana Establishment is anticipated to be located at:

179 Brook Street

Clinton, MA 01510

This meeting will contain the same information that was presented at the public meeting on August 26, 2019. There will be an opportunity for the public to ask additional questions.

12-10-19A11:20 RCVD



Notice of Public Meeting

Notice is hereby given that a Community Outreach Meeting for a Proposed Cannabis Cultivation and Processing Establishment is scheduled for:

Date: 18 December, 2019

Time: 6:00PM

Location: Clinton Senior Center

271 Church Street

Clinton, MA 01510

The Proposed Cultivator and Product Manufacturer Marijuana Establishment is anticipated to be located at:

179 Brook Street

Clinton, MA 01510

This meeting will contain the same information that was presented at the public meeting on August 26, 2019. There will be an opportunity for the public to ask additional questions.

Receipt #: 840-50180250-1-3790056-1
Clerk: 23

or call 1-800-410-7420.
YOUR OPINION COUNTS



Go to: <https://postalexperience.com/Pps>
840-5018-0250-001-00037-90056-01
or scan this code with your mobile device:

TELL US ABOUT YOUR RECENT POSTAL EXPERIENCE

HELP US SERVE YOU BETTER
www.usps.com/careers to apply.

NON HIRING. Please visit
Thank you for your business.
Refunds for guaranteed services only.
All sales final on stamps and postage.

Preview your Mail
Track your Packages
Sign up for FREE @
www.informmeddelivery.com

Credit Card Remitd
(Card Name: VISA)
(Account #: XXXXXXXXXXXXXXX6553)
(Approval #: 08114C)
(Transaction #: 358)
(AID: A0000000031010)
(AL: Visa Credit)
(PIN: Not Required)
Chip

\$16.30

Total: \$16.30

US Flag Bk1/20 1 \$11.00
Classics Forever 1 \$3.30
Letter (Domestic) (CLINTON, MA 01510) (Weight: 0 Lb 0.30 Oz) (Estimated Delivery Date) (Friday 12/13/2019) (Cert of Mail) (Attached Amount: \$0.00)
\$1.45

Product	Qty	Unit Price
US Flag Bk1/20	1	\$11.00
Classics Forever	1	\$3.30
Letter (Domestic)	1	\$0.55

CLINTON
320 HIGH ST
CLINTON, MA 01510-9998
241462-0510
(800)275-8777
12/11/2019 04:50 PM

PS Form 3817, April 2007 PSN 7530-02-000-9065

From: Liberty Composition
179 Brook Street
Clinton, MA 01510

To:

~~XXXXXXXXXX~~
Clinton, MA 01510

Postmark Here



Certificate of Mailing

To pay for, after stamps or meter postage has

Plan to Remain Compliant with Local Zoning

The proposed facility of Liberty Compassion will be located at 179 Brook St, Clinton, MA (the "Site"). The address is currently zoned within the Industrial District. According to the Clinton Zoning Bylaws, the Industrial District allows marijuana cultivation and manufacturing with special permits from the Planning Board. Liberty Compassion will comply with all requirements specified by the host community. Liberty Compassion will make no changes to the premises or its operation that would violate said bylaws. See zone map below, the subject property is outlined in blue.



- Zoning Districts**
- Business Retail (BR)
 - Commercial (C)
 - Industrial (I)
 - Residential (R2)
 - Residential Neighborhood (R1)

Liberty Compassion has worked with the Clinton Board of Selectmen, the Clinton Town Administrator, Clinton’s legal counsel and Clinton’s Planning Board to secure all necessary permitting to allow for

marijuana cultivation and manufacturing at the Site. Liberty Compassion has also worked with such persons to address security and operational requirements; present to Town stakeholders; and secure local government support. Liberty Compassion will regularly continue such interaction with such persons, and the CEO will coordinate communication with Building, Fire, Highway, Police and other appropriate departments and officials to ensure ongoing compliance with local laws relating to the design, building and operation of the marijuana establishment, including that which relates to signs, business hours, odor controls, safety, reporting and the like. Liberty Compassion, through its CEO and legal counsel, will continue to ensure compliance by timely reviewing ordinance changes; engaging in ongoing collaboration with Town officials and inspectors; and having monthly executive, internal meetings on local law proposals, changes, updates and compliance. With respect to local matters relating to zoning and/or other requirements to operate at such site, Liberty Compassion will also execute the following:

Diversion Mitigation: In cooperation with and to the extent requested by the Town's Police Department, and consistent with the regulations ("Regulations") of the Cannabis Control Commission ("CCC"), the Company will work with the Town's Police Department to implement a CCC-compliant diversion prevention plan, a form of which plan to be in place prior to the date of commencing sales. Such plan will include, but is not limited to, training employees to be aware of, observe, and report any unusual behavior in authorized visitors or other employees that may indicate the potential for diversion; and utilizing seed-to-sale tracking software to closely track all inventory.

Security: To the extent requested by the Town's Police Department, and consistent with the Regulations, Liberty Compassion will also work with the Town's Police Department in determining the placement of interior and exterior security cameras but at all times compliant with the Regulations and approval of the CCC. The Company will maintain a cooperative relationship with the Police Department, including but not limited to periodic meetings to review operational concerns, security, delivery schedule and procedures, cooperation in investigations, and communication to Police Department of any suspicious activities on or in the immediate vicinity of the Site and with regard to any anti-diversion procedures. Liberty Compassion also agrees to develop a crisis plan and train its security personnel in its use.

MIPs: The production, handling, marketing and sale of edible marijuana-infused products ("MIPs") by Liberty Compassion will be in accordance with the Regulations, including the packaging and labeling requirements which, among other things, provide that edible MIPs shall not bear a reasonable resemblance to any product available for consumption as a commercially available candy. Liberty Compassion shall obtain any necessary food preparation licenses annually from the Clinton Board of Health.

Consumption: The on-site consumption of marijuana products shall be prohibited.

**D
PC**

The Commonwealth of Massachusetts

William Francis Galvin
Secretary of the Commonwealth
One Ashburton Place, Boston, Massachusetts 02108-1512

FORM MUST BE TYPED

Restated Articles of Organization (General Laws Chapter 156D, Section 10.07; 950 CMR 113.35)

FORM MUST BE TYPED

(1) Exact name of corporation: Liberty Compassion, Inc.

(2) Registered office address: 179 Brook Street, Clinton, Massachusetts 01510
(number, street, city or town, state, zip code)

(3) Date adopted: November 9, 2018
(month, day, year)

(4) Approved by:

(check appropriate box)

the directors without shareholder approval and shareholder approval was not required;

OR

the board of directors and the shareholders in the manner required by G.L. Chapter 156D and the corporation's articles of organization.

(5) The following information is required to be included in the articles of organization pursuant to G.L. Chapter 156D, Section 2.02 except that the supplemental information provided for in Article VIII is not required:*

ARTICLE I

The exact name of the corporation is:

Liberty Compassion, Inc.

ARTICLE II

Unless the articles of organization otherwise provide, all corporations formed pursuant to G.L. Chapter 156D have the purpose of engaging in any lawful business. Please specify if you want a more limited purpose:**

* Changes to Article VIII must be made by filing a statement of change of supplemental information form.

ARTICLE III

State the total number of shares and par value, * if any, of each class of stock that the corporation is authorized to issue. All corporations must authorize stock. If only one class or series is authorized, it is not necessary to specify any particular designation.

WITHOUT PAR VALUE		WITH PAR VALUE		
TYPE	NUMBER OF SHARES	TYPE	NUMBER OF SHARES	PAR VALUE
		Preferred	182,884	\$0.01
		Common	246,385	\$0.01

ARTICLE IV

Prior to the issuance of shares of any class or series, the articles of organization must set forth the preferences, limitations and relative rights of that class or series. The articles may also limit the type or specify the minimum amount of consideration for which shares of any class or series may be issued. Please set forth the preferences, limitations and relative rights of each class or series and, if desired, the required type and minimum amount of consideration to be received.

See Attachment A

ARTICLE V

The restrictions, if any, imposed by the articles or organization upon the transfer of shares of any class or series of stock are:

None

ARTICLE VI

Other lawful provisions, and if there are no such provisions, this article may be left blank.

See Attachment B

ARTICLE VII

The effective date of organization of the corporation is the date and time the articles were received for filing if the articles are not rejected within the time prescribed by law. If a later effective date is desired, specify such date, which may not be later than the 90th day after the articles are received for filing:

It is hereby certified that these restated articles of organization consolidate all amendments into a single document. If a new amendment authorizes an exchange, or effects a reclassification or cancellation, of issued shares, provisions for implementing that action are set forth in these restated articles unless contained in the text of the amendment.

Specify the number(s) of the article(s) being amended: Article III, Article IV, Article V, Article VI

Signed by: 
(signature of authorized individual)

- Chairman of the board of directors,
- President,
- Other officer,
- Court-appointed fiduciary,

at 6 ... November 2018

Attachment A

SECTION 1. *General.*

The total number of shares of stock which the Corporation shall have the authority to issue is (a) two hundred forty six thousand three hundred eighty five (246,385) shares of common stock, par value \$0.01 per share (the "Common Stock") and one hundred eighty two thousand eight hundred eighty four (182,884) shares of preferred stock, par value \$0.01 per share (the "Preferred Stock"), as each is further designated herein.

The shares authorized in this Article IV may be issued by the Corporation from time to time as approved by its Board of Directors without the approval of its shareholders.

The designations, powers, preferences and relative, participating, optional or other special rights of, and the qualifications, limitations or restrictions upon, each class or series of stock shall be as set forth below in Sections 2 and 3 of this Article IV.

SECTION 2. *Common Stock*

Two hundred thirty two thousand nine hundred fifty two (232,952) shares of Common Stock shall be designated as Class A Common Stock (the "Class A Common Stock") and thirteen thousand four hundred thirty three (13,433) shares of Common Stock shall be designated as Class B Common Stock (the "Class B Common Stock"). Except as provided by law, the Common Stock shall be identical in all respects, except the Class B Common Stock shall have no voting rights. Each holder of shares of Class A Common Stock shall be entitled to one vote on all matters for each share held by such holder. The voting, dividend and liquidation rights of the holders of the Common Stock are subject to and qualified by the rights, powers and preferences of the holders of the Preferred Stock set forth herein.

Whenever there shall have been paid, or declared and set aside for payment, to the holders of the outstanding shares of any class of stock having preference over the Common Stock as to the payment of the dividends, the full amount of dividends to which such holders are respectively entitled in preference to the Common Stock, then dividends may be paid on the Common Stock and on any class or series of stock entitled to participate therewith to dividends, out of any assets legally available for the payment of dividends; but only when and as declared by the Board of Directors.

In the event of any liquidation, dissolution or winding up of the Corporation after there shall have been paid to or set aside for the holders of any class having preferences over the Common Stock in the event of liquidation, dissolution or winding up of the Corporation the full preferential amounts to which they are respectively entitled, the holders of the Common Stock, and of any class or series of stock entitled to participate therewith, in whole or in part, as to distribution of assets shall be entitled, after payment or provision for payment of all debts and liabilities of the Corporation to receive the remaining assets of the Corporation available for distribution, in cash or in kind, in proportion to their holding.

SECTION 3. *Preferred Stock.*

The Board of Directors of the Corporation is authorized within the limitations and restrictions stated in this Article IV by vote or votes from time to time adopted, to provide for the issuance of Preferred Stock in one or more series and to fix and state the voting powers, designations, preferences and relative, participating, optional or other special rights of the shares of each series and the qualifications, limitations and restrictions thereof, including, without limitation, the distinctive serial designation and the number of shares constituting such series and to increase or decrease the number of shares constituting any such series; and to increase or decrease the number of shares of any series subsequent to the issue of shares of that series, but not below the number of shares of such series then outstanding provided that, in case the number of shares of any series shall be so decreased, the shares then constituting such decreases shall resume the status which they had prior to the adoption of the resolution originally fixing the number of shares of such series and including further, without limitation, determination of one or more of the following:

- (a) The distinctive class or serial designation and number of shares constituting such class or series.
- (b) The dividend rates or the amount of dividends to be paid on the shares of such series, whether dividends shall be cumulative and, if so, from which date or dates, the payment date or dates for dividends, and the participating, preferences or other special rights, if any, with respect to dividends;
- (c) The voting powers, if any, of shares of such series;
- (d) Whether the shares of such series shall be redeemable and, if so, the price or prices at which, and the terms and conditions

- (e) The amount or amounts payable upon the shares of such series and any preferences applicable thereto in the event of voluntary or involuntary liquidation, dissolution or winding up of the Corporation;
- (f) Whether the shares of such series shall be entitled to the benefit of a sinking or retirement fund to be applied to the purchase or redemption of such shares, and if so entitled, the amount of such fund and the manner of its application, including the price at which such shares may be redeemed or purchased through the application of such fund;
- (g) Whether the shares of such series shall be convertible into, or exchangeable for, shares of any other class or classes or of any other series of the same or any other class or classes of stock of the Corporation and, if so, convertible or exchangeable, the conversion price or prices, or the rate or rates of exchange, and the adjustments thereof, if any, at which such conversion or exchange may be made, and any other terms and conditions of such conversion or exchange;
- (h) The price or other consideration for which the shares of such series shall be issued;
- (i) Whether the shares of such series which are redeemed or converted shall have the status of authorized but unissued shares of Preferred Stock and whether such shares may be reissued as shares of the same or any other series of stock; and
- (j) Such other powers, preferences, special rights, qualifications, limitations and restrictions thereof as the Board of Directors of the Corporation may deem advisable.

SECTION 3(a). *Series A Convertible Preferred Stock*

(1) *Designation and Number of Shares.* The shares of such series of Preferred Stock shall be designated as "Series A Participating Preferred Stock" (the "Series A Preferred Stock"), par value \$0.01 per share. The number of shares initially constituting the Series A Preferred Stock shall be one hundred sixty nine thousand four hundred fifty one (169,451).

(2) *Voting Rights.*

(a) *General.* On any matter presented to the shareholders of the Corporation for their action or consideration at any meeting of shareholders of the Corporation (or by written consent of shareholders in lieu of meeting), each holder of outstanding shares of Series A Preferred Stock shall be entitled to cast the number of votes equal to the number of whole shares of Common Stock into which the shares of Series A Preferred Stock held by such holder are convertible as of the record date for determining shareholders entitled to vote on such matter. Except as provided by law or by the other provisions of this Restated Articles of Organization, holders of Series A Preferred Stock shall vote together with the holders of Class A Common Stock as a single class and on an as-converted to Common Stock basis.

(b) *Series A Preferred Stock Protective Provisions.* At any time when shares of Series A Preferred Stock are outstanding, in addition to any other voting rights afforded to the holders of Series A Preferred Stock, the Corporation shall not, either directly or indirectly by amendment, merger, consolidation or otherwise, do any of the following without (in addition to any other vote required by law) the written consent or affirmative vote of at least a majority of the holders of the Series A Preferred Stock, voting as a separate class, given in writing or by vote at a meeting, consenting or voting (as the case may be) separately as a class, and any such act or transaction entered into without such consent or vote shall be null and void *ab initio*, and of no force or effect.

(i) liquidate, dissolve or wind-up the business and affairs of the Corporation, effect any merger or consolidation or any Deemed Liquidation Event (as hereinafter defined), or consent to any of the foregoing;

(ii) amend, alter or repeal any provision of this Restated Articles of Organization or Bylaws of the Corporation in a manner that adversely affects the powers, preferences or rights of the Series A Preferred Stock;

(iii) create, or authorize the creation of, or issue or obligate itself to issue shares of, any additional class or series of capital stock, or increase the authorized number of shares of Series A Preferred Stock or increase the authorized number of shares of any additional class or series of capital stock of the Corporation;

(iv) (A) reclassify, alter or amend any existing security of the Corporation that is *pari passu* with the Series A Preferred Stock in respect of the distribution of assets on the liquidation, dissolution or winding up of the Corporation, the payment of dividends or rights of redemption, if such reclassification, alteration or

is junior to the Series A Preferred Stock in respect of the distribution of assets on the liquidation, dissolution or winding up of the Corporation, the payment of dividends or rights of redemption, if such reclassification, alteration or amendment would render such other security senior to or pari passu with the Series A Preferred Stock in respect of any such right, preference or privilege;

(v) purchase or redeem (or permit any subsidiary to purchase or redeem) or pay or declare any dividend or make any distribution on, any shares of capital stock of the Corporation;

(vi) enter into or modify any contractual or other business relationship between the Corporation or a subsidiary, on one hand, and any affiliate of the Corporation or a subsidiary, on the other hand;

(vii) adopt an annual budget for the Corporation or a subsidiary and making expenditures in any one transaction or series of related transactions (or agreements providing for the same) that exceed by fifteen percent (15%) or more of any expenditures (by line item) set forth in the approved budget for the Corporation or a subsidiary;

(viii) any sale or exchange of any the assets of the Corporation, other than in the ordinary course of business; or

(ix) create, or authorize the creation of, or issue, or authorize the issuance of any debt security or create any lien or security interest (except for purchase money liens or statutory liens of landlords, mechanics, materialmen, workmen, warehousemen and other similar persons arising or incurred in the ordinary course of business) or incur other indebtedness for borrowed money, including but not limited to obligations and contingent obligations under guarantees, or permit any subsidiary to take any such action with respect to any debt security lien, security interest or other indebtedness for borrowed money, other than equipment leases, bank lines of credit or trade payables incurred in the ordinary course.

(3) *Rights and Terms.* The Series A Preferred shall have the rights and terms as set forth in Section 3(c) hereof.

SECTION 3(b). *Series B Convertible Preferred Stock*

(1) *Designation and Number of Shares.* The shares of such series of Preferred Stock shall be designated as "Series B Participating Preferred Stock" (the "Series B Preferred Stock"), par value \$0.01 per share. The number of shares initially constituting the Series B Preferred Stock shall be thirteen thousand four hundred thirty three (13,433).

(2) *Voting Rights.* Except as provided by law, the Series B Preferred Stock shall have no voting rights.

(3) *Rights and Terms.* The Series B Preferred shall have the rights and terms as set forth in Section 3(c) hereof.

SECTION 3(c). *Rights and Terms of the Preferred Stock*

The Preferred Stock (both Series A Preferred Stock and the Series B Preferred Stock) shall have the following rights and term:

(1) *Dividends.* The Corporation shall not declare, pay or set aside any dividends on shares of any other class or series of capital stock of the Corporation unless (in addition to the obtaining of any consents required elsewhere in this Restated Articles of Organization) the holders of the Preferred Stock then outstanding shall first receive, or simultaneously receive, a dividend on each outstanding share of Preferred Stock in an amount at least equal to (i) in the case of a dividend on Common Stock or any class or series that is convertible into Common Stock, that dividend per share of Preferred Stock as would equal the product of (A) the dividend payable on each share of such class or series determined, if applicable, as if all shares of such class or series had been converted into Common Stock and (B) the number of shares of Common Stock issuable upon conversion of a share of Preferred Stock, in each case calculated on the record date for determination of holders entitled to receive such dividend or (ii) in the case of a dividend on any class or series that is not convertible into Common Stock, at a rate per share of Preferred Stock determined by (A) dividing the amount of the dividend payable on each share of such class or series of capital stock by the original issuance price of such class or series of capital stock (subject to appropriate adjustment in the event of any stock dividend, stock split, combination or other similar recapitalization with respect to such class or series) and (B) multiplying such fraction by an amount equal to the Preferred Original Issue Price (as defined below); provided that, if the Corporation declares, pays or sets aside, on the same date, a dividend on shares of more than one class or series of capital stock of the Corporation, the dividend payable to the holders of Preferred Stock pursuant hereunder shall be calculated based upon the dividend on the class or series of capital stock that would result in the highest

(2) *Preferred Participating Payments; Liquidation*

(i) *Preferential Payments to Holders of Preferred Stock.* In the event of any voluntary or involuntary liquidation, dissolution or winding up of the Corporation, the holders of shares of Preferred Stock then outstanding shall be entitled to be paid out of the assets of the Corporation available for distribution to its shareholders or, in the case of a Deemed Liquidation Event (as defined below), out of the consideration payable to shareholders in such Deemed Liquidation Event before any payment shall be made to the holders of Common Stock by reason of their ownership thereof, an amount per share equal to one (1) times the Preferred Original Issue Price, plus any dividends declared but unpaid thereon. If upon any such liquidation, dissolution or winding up of the Corporation or Deemed Liquidation Event, the assets of the Corporation available for distribution to its shareholders shall be insufficient to pay the holders of shares of Preferred Stock the full amount to which they shall be entitled hereunder, the holders of shares of Preferred Stock shall share ratably in any distribution of the assets available for distribution in proportion to the respective amounts which would otherwise be payable in respect of the shares held by them upon such distribution if all amounts payable on or with respect to such shares were paid in full.

(ii) *Distribution of Remaining Assets.* In the event of any voluntary or involuntary liquidation, dissolution or winding up of the Corporation, after the payment in full of all Preferred Liquidation Amounts required to be paid to the holders of shares of Preferred Stock the remaining assets of the Corporation available for distribution to its shareholders or, in the case of a Deemed Liquidation Event, the consideration not payable to the holders of shares of Preferred Stock hereunder, as the case may be, shall be distributed among the holders of the shares of Preferred Stock and Common Stock, pro rata based on the number of shares held by each such holder, treating for this purpose all such securities as if they had been converted to Common Stock pursuant to the terms of this Restated Articles of Organization immediately prior to such liquidation, dissolution or winding up of the Corporation. The aggregate amount which a holder of a share of Preferred Stock is entitled to receive under Section 3(c)(2) hereof is hereinafter referred to as the "Preferred Liquidation Amount."

(iii) *Deemed Liquidation.*

(A) *Definition.* Each of the following events shall be considered a "Deemed Liquidation Event:

(I) a merger or consolidation in which the Corporation is a constituent party or a subsidiary of the Corporation is a constituent party and the Corporation issues shares of its capital stock pursuant to such merger or consolidation, except any such merger or consolidation involving the Corporation or a subsidiary in which the shares of capital stock of the Corporation outstanding immediately prior to such merger or consolidation continue to represent, or are converted into or exchanged for shares of capital stock that represent, immediately following such merger or consolidation, at least a majority, by voting power, of the capital stock of (1) the surviving or resulting corporation; or (2) if the surviving or resulting corporation is a wholly owned subsidiary of another corporation immediately following such merger or consolidation, the parent corporation of such surviving or resulting corporation; or

(II) the sale, lease, transfer, exclusive license or other disposition, in a single transaction or series of related transactions, by the Corporation or any subsidiary of the Corporation of all or substantially all the assets of the Corporation and its subsidiaries taken as a whole or (2) the sale or disposition (whether by merger, consolidation or otherwise, and whether in a single transaction or a series of related transactions) of one or more subsidiaries of the Corporation if substantially all of the assets of the Corporation and its subsidiaries taken as a whole are held by such subsidiary or subsidiaries, except where such sale, lease, transfer, exclusive license or other disposition is to a wholly owned subsidiary of the Corporation.

(B) *Effecting a Deemed Liquidation Event.* The Corporation shall not have the power to effect a Deemed Liquidation Event referred to in Section 3(c)(2)(iii) unless the agreement or plan of merger or consolidation for such transaction (the "Merger Agreement") provides that the consideration payable to the shareholders of the Corporation in such Deemed Liquidation Event shall be paid to the holders of capital stock of the Corporation in accordance with Section 3(c)(2) hereof.

In the event of a Deemed Liquidation Event, if any portion of the consideration payable to the shareholders of the Corporation is payable only upon satisfaction of contingencies (the "Additional Consideration"), the Merger Agreement shall provide that (a) the portion of such consideration that is not Additional Consideration (such portion, the "Initial Consideration") shall be allocated among the holders of capital stock of the Corporation in accordance with Section 3(c)(2) as if the Initial Consideration were the only consideration payable in connection with such Deemed Liquidation Event; and (b) any Additional Consideration which becomes payable to the shareholders of the Corporation upon satisfaction of such

Section 3(c)(2) after taking into account the previous payment of the Initial Consideration as part of the same transaction. For the purposes of this Section 3(c)(2)(iii)(B), consideration placed into escrow or retained as a holdback to be available for satisfaction of indemnification or similar obligations in connection with such Deemed Liquidation Event shall be deemed to be Additional Consideration.

(3) *Conversion Rights.* The holders of the Preferred Stock shall have conversion rights as follows (the "Conversion Rights"):

(i) *Right to Convert.*

(A) *Conversion Ratio.* Each share of Series A Preferred Stock shall be convertible, at the option of the holder thereof, at any time and from time to time, and without the payment of additional consideration by the holder thereof, into such number of fully paid and non-assessable shares of Class A Common Stock as is determined by dividing the Preferred Original Issue Price by the Preferred Conversion Price (as defined below) in effect at the time of conversion. Each share of Series B Preferred Stock shall be convertible, at the option of the holder thereof, at any time and from time to time, and without the payment of additional consideration by the holder thereof, into such number of fully paid and non-assessable shares of Class B Common Stock as is determined by dividing the Preferred Original Issue Price by the Preferred Conversion Price (as defined below) in effect at the time of conversion. The "Preferred Conversion Price" shall be equal to \$1.00. In the event of a liquidation, dissolution or winding up of the Corporation or a Deemed Liquidation Event, the Conversion Rights shall terminate at the close of business on the last full day preceding the date fixed for the payment of any such amounts distributable on such event to the holders of Preferred Stock.

(B) *Fractional Shares.* No fractional shares of Common Stock shall be issued upon conversion of the Preferred Stock. In lieu of any fractional shares to which the holder would otherwise be entitled, the Corporation shall pay cash equal to such fraction multiplied by the fair market value of a share of Common Stock as determined in good faith by the Board of Directors of the Corporation. Whether or not fractional shares would be issuable upon such conversion shall be determined on the basis of the total number of shares of Preferred Stock the holder is at the time converting into Common Stock and the aggregate number of shares of Common Stock issuable upon such conversion.

(C) *Mechanics of Conversion.* In order for a holder of Preferred Stock to voluntarily convert shares of Preferred Stock into shares of Common Stock, such holder shall (a) provide written notice to the Corporation's transfer agent at the office of the transfer agent for the Preferred Stock (or at the principal office of the Corporation if the Corporation serves as its own transfer agent) that such holder elects to convert all or any number of such holder's shares of Preferred Stock and, if applicable, any event on which such conversion is contingent and (b), if such holder's shares are certificated, surrender the certificate or certificates for such shares of Preferred Stock (or, if such registered holder alleges that such certificate has been lost, stolen or destroyed, a lost certificate affidavit and agreement reasonably acceptable to the Corporation to indemnify the Corporation against any claim that may be made against the Corporation on account of the alleged loss, theft or destruction of such certificate), at the office of the transfer agent for the Preferred Stock (or at the principal office of the Corporation if the Corporation serves as its own transfer agent). Such notice shall state such holder's name or the names of the nominees in which such holder wishes the shares of Common Stock to be issued. If required by the Corporation, any certificates surrendered for conversion shall be endorsed or accompanied by a written instrument or instruments of transfer, in form satisfactory to the Corporation, duly executed by the registered holder or his, her or its attorney duly authorized in writing. The close of business on the date of receipt by the transfer agent (or by the Corporation if the Corporation serves as its own transfer agent) of such notice and, if applicable, certificates (or lost certificate affidavit and agreement) shall be the time of conversion (the "Conversion Time"), and the shares of Common Stock issuable upon conversion of the specified shares shall be deemed to be outstanding of record as of such date. The Corporation shall, as soon as practicable after the Conversion Time pay in cash such amount as required herein in lieu of any fraction of a share of Common Stock otherwise issuable upon such conversion and (iii) pay all declared but unpaid dividends on the shares of Preferred Stock converted.

The Corporation shall at all times when the Preferred Stock shall be outstanding, reserve and keep available out of its authorized but unissued capital stock, for the purpose of effecting the conversion of the Preferred Stock, such number of its duly authorized shares of Common Stock as shall from time to time be sufficient to effect the conversion of all outstanding Preferred Stock; and if at any time the number of authorized but unissued shares of Common Stock shall not be sufficient to effect the conversion of all then outstanding shares of the Preferred Stock, the Corporation shall take such corporate action as may be necessary to increase its authorized but unissued shares of Common Stock to such number of shares as shall be sufficient for such purposes, including, without limitation,

Articles of Organization. Before taking any action which would cause an adjustment reducing the Preferred Conversion Price below the then par value of the shares of Common Stock issuable upon conversion of the Preferred Stock, the Corporation will take any corporate action which may, in the opinion of its counsel, be necessary in order that the Corporation may validly and legally issue fully paid and non-assessable shares of Common Stock at such adjusted Preferred Conversion Price.

All shares of Preferred Stock which shall have been surrendered for conversion as herein provided shall no longer be deemed to be outstanding and all rights with respect to such shares shall immediately cease and terminate at the Conversion Time, except only the right of the holders thereof to receive shares of Common Stock in exchange therefor, to receive payment in lieu of any fraction of a share otherwise issuable upon such conversion as provided herein and to receive payment of any dividends declared but unpaid thereon. Any shares of Preferred Stock so converted shall be retired and cancelled and may not be reissued as shares of such series, and the Corporation may thereafter take such appropriate action (without the need for shareholder action) as may be necessary to reduce the authorized number of shares of Preferred Stock accordingly.

The Corporation shall pay any and all issue and other similar taxes that may be payable in respect of any issuance or delivery of shares of Common Stock upon conversion of shares of Preferred Stock. The Corporation shall not, however, be required to pay any tax which may be payable in respect of any transfer involved in the issuance and delivery of shares of Common Stock in a name other than that in which the shares of Preferred Stock so converted were registered, and no such issuance or delivery shall be made unless and until the person or entity requesting such issuance has paid to the Corporation the amount of any such tax or has established, to the satisfaction of the Corporation, that such tax has been paid.

SECTION 4. *No Impairment.* The Corporation shall not, by amendment of its Articles of Organization or through any reorganization, transfer of assets, consolidation, merger, dissolution, issue or sale of securities or any other voluntary action, avoid or seek to avoid the observance or performance of any of the terms of Preferred Stock set forth herein. Without limiting the generality of the foregoing, the Corporation shall take all action that may be necessary or appropriate in order that the Corporation may validly and legally issue fully paid and nonassessable shares of stock on the conversion of all Preferred Stock from time to time outstanding.

SECTION 5. *Amended and Restated Shareholders Agreement.* The terms and conditions of that certain Amended and Restated Shareholders Agreement by and among the Corporation and its shareholders dated as of the date hereof as referred to and incorporated herein by reference.

Attachment B

Other Lawful Provisions

SECTION 1. The Board of Directors is expressly authorized to make, amend or repeal the By-Laws of the Corporation in whole or in part, except with respect to any provision thereof which by law or the By-Laws requires action by the shareholders, and subject to the power of the shareholders to amend or repeal any By-Law adopted by the Board of Directors.

SECTION 2. Any action which may be taken by shareholders may be taken without a meeting if (i) all shareholders entitled to vote on the matter or (ii) the shareholders having not less than the minimum number of votes necessary to take the action at a meeting at which all shareholders entitled to vote on the action are present and voting consent to the action in writing and the written consents are delivered to the Corporation for inclusion with the records of the meetings of shareholders within 60 days of the earliest dated consent delivered to the Corporation.

SECTION 3. The Board of Directors may consist of one, two or more individuals regardless of the number of shareholders.

SECTION 4. The Corporation shall, to the extent legally permissible, indemnify each person (and his heirs, executors, administrators, or other legal representatives) who is, or shall have been, a director or officer of the Corporation or any person who is serving, or shall have served, at the request of the Corporation as a director or officer of another corporation, against all liabilities and expenses (including judgments, fines, penalties and attorneys' fees and all amounts paid in compromise or settlement) reasonably incurred by any such director, officer or person in connection with, or arising out of, any action, suit or proceeding in which any such director, officer or person may be a party defendant or with which he may be threatened or otherwise involved, directly or indirectly, by reason of his being or having been a director or officer of the Corporation or such other corporation, except in relation to matters as to which any such director, officer or person shall be finally adjudged, other than by consent, in such action, suit or proceeding not to have acted in good faith in the reasonable belief that his action was in the best interests of the Corporation; provided, however, that indemnity shall not be made with respect to such amounts paid in compromise or settlement, unless:

(a) such compromise or settlement shall have been approved as in the best interests of the Corporation, after notice that it involves such indemnification by:

(i) The Board of Directors by a majority of a quorum consisting of directors who were not parties to such action, suit or proceeding, or by

(ii) The shareholders of the Corporation by a majority vote of a quorum consisting of shareholders who were not parties to such action, suit or proceeding, or

(b) in the absence of action by disinterested directors or shareholders as above provided, there has been obtained at the request of a majority of the Board of Directors then in office a written opinion of independent legal counsel to the effect that the director or officer to be indemnified appears to have acted in good faith in the reasonable belief that his action was in the best interests of the Corporation.

Upon request therefor by any director, officer, or person enumerated in the preceding paragraph of this Article, the Corporation may from time to time, if authorized by the Board of Directors, prior to final adjudication or compromise or settlement of the matter or matters as to which indemnification is claimed, advance to such director, officer or person all expenses incurred by him to date of such request. Any advance made pursuant to this provision shall be made on the condition that the director, officer or person receiving such advance shall repay to the Corporation any amounts so advanced if, upon the termination of the matter or matters as to which such advances were made, such director, officer or person shall not be entitled to indemnification under the preceding paragraph of this Article.

The foregoing right to indemnification shall not be exclusive of any other rights to which any such director, officer or person is entitled under any agreement, vote of shareholders, statute, or as a matter of law, or otherwise.

The provisions of this Article are separable, and if any provision or portion hereof shall for any reason be held inapplicable, illegal or ineffective, this shall not prevent any other provision or portion hereof from applying, and shall not affect any right of indemnification existing otherwise than under this Article.

SECTION 5. No director shall be personally liable to the Corporation or its shareholders for monetary damages for breach of fiduciary duty as a director notwithstanding any provision of law imposing such liability; provided, however, that such limitation on liability will not eliminate or limit the liability of a director (i) for any breach of the director's duty of loyalty to the Corporation or its shareholders, (ii) for acts or omissions not in good faith or which involve intentional misconduct or a knowing violation of law,

derived an improper personal benefit. If the Massachusetts Business Corporation Act is amended after the effective date of these Articles of Organization, to authorize corporate action further eliminating or limiting the personal liability of directors, then the liability of a director of the Corporation shall be eliminated or limited to the fullest extent permitted by the Massachusetts Business Corporation Act, as so amended.

SECTION 6. Shareholders having the right to vote at least twenty-five percent (25%) of all votes entitled to be cast on any issue to be considered at a meeting of shareholders shall have the right to call a special meeting of shareholders to consider and act upon such issue.

THE COMMONWEALTH OF MASSACHUSETTS

I hereby certify that, upon examination of this document, duly submitted to me, it appears that the provisions of the General Laws relative to corporations have been complied with, and I hereby approve said articles; and the filing fee having been paid, said articles are deemed to have been filed with me on:

November 14, 2018 04:47 PM

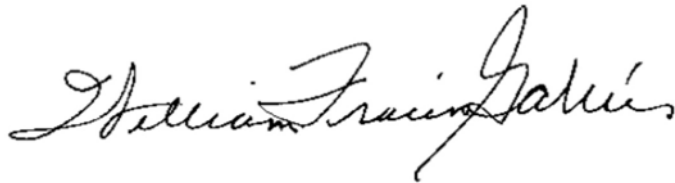
A handwritten signature in black ink, reading "William Francis Galvin". The signature is written in a cursive style with a large, prominent initial "W".

WILLIAM FRANCIS GALVIN

Secretary of the Commonwealth

AMENDED AND RESTATED ByLAWS

OF

LIBERTY COMPASSION, INC.

ARTICLE I

ARTICLES OF ORGANIZATION

Section 1. Restated Articles of Organization. The name of the Corporation shall be as set forth in the Restated Articles of Organization. These ByLaws, the powers of the Corporation and of its directors and shareholders, and all matters concerning the conduct and regulation of the business of the Corporation, shall be subject to the Restated Articles of Organization. All references in these ByLaws to the Articles of Organization or the Restated Articles of Organization shall mean the restated articles of organization of the Corporation, as from time to time in effect. All references in these ByLaws to the MBCA shall mean the Massachusetts Business Corporation Act, M.G.L. c. 156D, *et seq.*, as from time to time in effect.

ARTICLE II

SHAREHOLDERS

Section 1. Annual Meeting. The Corporation shall hold an annual meeting of shareholders at a time and on a date fixed by the board of directors within six (6) months after the end of the Corporation's fiscal year. The purposes for which the annual meeting are to be held, in addition to those prescribed by the Restated Articles of Organization, shall be for electing directors and for such other purposes as shall be specified in the notice for the meeting, and only business within such purposes may be conducted at the meeting.

Section 2. Special Meetings. Special meetings of the shareholders may be called by the President or by the board of directors, and shall be called by the Secretary, or in case of the death, absence, incapacity or refusal of the Secretary, by another officer, if the holders of at least ten percent (10%), or such lesser percentage as the Restated Articles of Organization permit, of all the votes entitled to be cast on any issue to be considered at the proposed special meeting sign, date, and deliver to the Secretary one (1) or more written demands for the meeting describing the purpose for which it is to be held. Only business within the purpose or purposes described in the meeting notice may be conducted at a special shareholders' meeting.

Section 3. Place of Meetings. All meetings of shareholders shall be held at the principal office of the Corporation or at such other place as the board of directors, the President, or the person or persons calling the meeting may determine, or solely by means of remote communication in accordance with Section 11 of this Article.

Section 4. Requirement of Notice. A written notice of the date, time, and place of each annual and special shareholders' meeting describing the purposes of the meeting shall be given to shareholders entitled to vote at the meeting (and, to the extent required by law or the Restated

Articles of Organization, to shareholders not entitled to vote at the meeting) no fewer than seven (7) and no more than sixty (60) days before the meeting date. If an annual or special meeting of shareholders is adjourned to a different date, time or place, notice need not be given of the new date, time or place if the new date, time or place, if any, is announced at the meeting before adjournment. If a new record date for the adjourned meeting is fixed, however, notice of the adjourned meeting shall be given under this Section to persons who are shareholders as of the new record date. All notices to shareholders shall conform to the requirements of Article IV.

Section 5. Waiver of Notice. A shareholder may waive any notice required by law, the Restated Articles of Organization, or these ByLaws before or after the date and time stated in the notice. The waiver shall be in writing, be signed by the shareholder entitled to the notice, and be delivered to the Corporation for inclusion with the records of the meeting. A shareholder's attendance at a meeting (a) waives objection to lack of notice or defective notice of the meeting, unless the shareholder at the beginning of the meeting objects to holding the meeting or transacting business at the meeting; and (b) waives objection to consideration of a particular matter at the meeting that is not within the purpose or purposes described in the meeting notice, unless the shareholder objects to considering the matter when it is presented.

Section 6. Quorum.

(a) Unless otherwise provided by law, or in the Restated Articles of Organization, these ByLaws or a resolution of the directors requiring satisfaction of a greater quorum requirement for any voting group, a majority of the votes entitled to be cast on the matter by a voting group constitutes a quorum of that voting group for action on that matter. As used in these ByLaws, a voting group includes all shares of one (1) or more classes or series that, under the Restated Articles of Organization or the MBCA, are entitled to vote and to be counted together collectively on a matter at a meeting of shareholders.

(b) A share once represented for any purpose at a meeting is deemed present for quorum purposes for the remainder of the meeting and for any adjournment of that meeting unless (1) the shareholder attends solely to object to lack of notice, defective notice or the conduct of the meeting on other grounds and does not vote the shares or otherwise consent that they are to be deemed present, or (2) in the case of an adjournment, a new record date is or shall be set for that adjourned meeting.

Section 7. Voting and Proxies. Unless the Restated Articles of Organization provide otherwise, each outstanding share that is entitled to vote, is entitled to one (1) vote on each matter voted on at a shareholders' meeting. A shareholder entitled to vote may vote his or her shares in person or may appoint a proxy to vote or otherwise act for him or her by signing an appointment form, either personally or by his or her attorney-in-fact. An appointment of a proxy is effective when received by the Secretary or other officer or agent authorized to tabulate votes. Unless otherwise provided in the appointment form, an appointment is valid for a period of eleven (11) months from the date the shareholder signed the form or, if it is undated, from the date of its receipt by the officer or agent. Such proxy shall entitle the holder thereof to vote at any adjournment of such meeting, but shall not be valid after the final adjournment of such meeting.

Section 8. Action at Meeting. If a quorum of a voting group exists, favorable action on a matter, other than the election of Directors, is taken by such voting group if the votes cast within the group favoring the action exceed the votes cast opposing the action, unless a greater number of affirmative votes is required by law, or the Restated Articles of Organization, these ByLaws or a resolution of the board of directors requiring receipt of a greater affirmative vote of the shareholders, including more separate voting groups. Directors are elected by a plurality of the votes cast by the shares entitled to vote in the election at a meeting at which a quorum is present. No ballot shall be required for such election unless requested by a shareholder present or represented at the meeting and entitled to vote in the election.

Section 9. Action without Meeting by Written Consent. Any action taken at a shareholders' meeting may be taken without a meeting if the action is taken either (1) by all shareholders entitled to vote on the action; or (2) to the extent permitted by the Restated Articles of Organization, by shareholders having not less than the minimum number of votes necessary to take the action at a meeting at which all shareholders entitled to vote on the action are present and voting. The action shall be evidenced by one (1) or more written consents that describe the action taken, is/are signed by shareholders having the requisite votes, bear the date of the signatures of such shareholders, and is/are delivered to the Corporation for inclusion with the records of meetings within sixty (60) days of the earliest dated consent delivered to the Corporation as required by this Section. A consent signed under this Section has the effect of a vote at a meeting for all purposes. If the shareholders take action by written consent, the Corporation shall give such notice of the action to shareholders who have not signed the consent as required by the MBCA.

Section 10. Record Date. The board of directors may fix the record date in order to determine the shareholders entitled to notice of a shareholders' meeting, to demand a special meeting, to vote, or to take any other action. If a record date for a specific action is not fixed by the board of directors, and is not supplied by law, the record date shall be the close of business either on the day before the first notice is sent to shareholders, or, if no notice is sent, on the day before the meeting or, in the case of action without a meeting by written consent, the date the first shareholder signs the consent or in the case of a special meeting by demand the date the first shareholder signs the demand. A record date fixed under this Section may not be more than seventy (70) days before the meeting or action requiring a determination of shareholders. A determination of shareholders entitled to notice of or to vote at a shareholders' meeting is effective for any adjournment of the meeting unless the board of directors fixes a new record date, which it shall do if the meeting is adjourned to a date more than one hundred twenty (120) days after the date fixed for the original meeting.

Section 11. Meetings by Remote Communications. Unless otherwise provided in the Restated Articles of Organization, if authorized by the board of directors, any annual or special meeting of shareholders need not be held at any place but may instead be held solely by means of remote communication; and subject to such guidelines and procedures as the board of directors may adopt, shareholders and proxyholders not physically present at a meeting of shareholders may, by means of remote communications, (a) participate in a meeting of shareholders; and (b) be deemed present in person and vote at a meeting of shareholders whether such meeting is to be held at a designated place or solely by means of remote communication, provided that (1) the Corporation shall implement reasonable measures to verify that each person deemed present and

permitted to vote at the meeting by means of remote communication is a shareholder or proxyholder; (2) the Corporation shall implement reasonable measures to provide such shareholders and proxyholders a reasonable opportunity to participate in the meeting and to vote on matters submitted to the shareholders, including providing an opportunity to read or hear the proceedings of the meeting substantially and concurrently with such proceedings; and (3) if any shareholder or proxyholder votes or takes other action at the meeting by means of remote communication, a record of such vote or other action shall be maintained by the Corporation.

Section 12. Form of Shareholder Action, By Electronic Transmission

(a) Any vote, consent, waiver, proxy appointment or other action by a shareholder or by the proxy or other agent of any shareholder shall be considered given in writing, dated and signed, if, in lieu of any other means permitted by law, it consists of an electronic transmission that sets forth or is delivered with information from which the Corporation can determine (1) that the electronic transmission was transmitted by the shareholder, proxy or agent, or by a person authorized to act for the shareholder, proxy or agent; and (2) the date on which such shareholder, proxy, agent or authorized person transmitted the electronic transmission. The date on which the electronic transmission is transmitted shall be considered to be the date on which it was signed. The electronic transmission shall be considered received by the Corporation if it has been sent to any address specified by the Corporation for the purpose or, if no address has been specified, to the principal office of the Corporation, addressed to the Secretary or other officer or agent having custody of the records of proceedings of shareholders.

(b) Any copy, facsimile or other reliable reproduction of a vote, consent, waiver, proxy appointment or other action by a shareholder or by the proxy or other agent of any shareholder may be substituted or used in lieu of the original writing for any purpose for which the original writing could be used, but the copy, facsimile or other reproduction shall be a complete reproduction of the entire original writing.

Section 13. Shareholders List for Meeting.

(a) After fixing a record date for a shareholders' meeting, the Corporation shall prepare an alphabetical list of the names of all its shareholders who are entitled to notice of the meeting. The list shall be arranged by voting group, and within each voting group by class or series of shares, and show the address of and number of shares held by each shareholder, but need not include an electronic mail address or other electronic contact information for any shareholder.

(b) The shareholders list shall be available for inspection by any shareholder, beginning two (2) business days after notice is given of the meeting for which the list was prepared and continuing through the meeting, (1) at the Corporation's principal office or at a place identified in the meeting notice in the city where the meeting will be held; or (2) on a reasonably accessible electronic network, provided that the information required to gain access to such list is provided with the notice of the meeting. If the meeting is to be held solely by means of remote communication, the list shall be made available on an electronic network.

(c) A shareholder, or his or her agent or attorney, is entitled on written demand to inspect and, subject to the requirements of Section 16.02(c) of the MBCA, to copy the list, during regular business hours and at his or her expense, during the period when it is available for inspection.

(d) The Corporation shall make the shareholders list available at the meeting, and any shareholder or his or her agent or attorney is entitled to inspect the list at any time during the meeting or any adjournment.

ARTICLE III

DIRECTORS

Section 1. Powers. All corporate power shall be exercised by or under the authority of, and the business and affairs of the Corporation shall be managed under the direction of, its board of directors.

Section 2. Number and Election. The board of directors shall be constituted in accordance with the Restated Articles of Organization. Except as otherwise provided in the Restated Articles of Organization, the board of directors shall be elected by the shareholders entitled to vote thereon.

Section 3. Vacancies. Except as otherwise provided in the Restated Articles of Organization, if a vacancy occurs on the board of directors, including a vacancy resulting from an increase in the number of directors, (a) the shareholders entitled to vote may fill the vacancy; (b) the board of directors may fill the vacancy; or (c) if the directors remaining in office constitute fewer than a quorum of the board, they may fill the vacancy by the affirmative vote of a majority of all the directors remaining in office. A vacancy that will occur at a specific later date may be filled before the vacancy occurs but the new director may not take office until the vacancy occurs.

Section 4. Change in Size of the Board of Directors. Except as otherwise provided in the Restated Articles of Organization, the number of directors may be fixed or changed from time to time by the shareholders entitled to vote or the board of directors, and the board of directors may increase or decrease the number of directors last approved by the shareholders entitled to vote.

Section 5. Tenure. Except as otherwise provided in the Restated Articles of Organization, the terms of all directors shall expire at the next annual shareholders' meeting following their election. A decrease in the number of directors does not shorten an incumbent director's term. The term of a director elected to fill a vacancy shall expire at the next shareholders' meeting at which directors are elected. Despite the expiration of a director's term, he or she shall continue to serve until his or her successor is elected and qualified or until there is a decrease in the number of directors.

Section 6. Resignation. Except as otherwise provided in the Restated Articles of Organization, a director may resign at any time by delivering written notice of resignation to the board of directors, its chairman, if any, or to the Corporation. A resignation is effective when the notice is delivered unless the notice specifies a later effective date.

Section 7. Removal. Except as otherwise provided in the Restated Articles of Organization, the shareholders entitled to vote may remove one (1) or more directors with or without cause. A director may be removed for cause by the directors by vote of a majority of the directors then in office. A director may be removed by the shareholders entitled to vote or by the directors only at a meeting called for the purpose of removing him or her, and the meeting notice must state that the purpose, or one of the purposes, of the meeting is removal of the director.

Section 8. Regular Meetings. Except as otherwise provided in the Restated Articles of Organization, regular meetings of the board of directors may be held at such times and places as shall from time to time be fixed by the board of directors without notice of the date, time, place or purpose of the meeting.

Section 9. Special Meetings. Except as otherwise provided in the Restated Articles of Organization, special meetings of the board of directors may be called by the President, by the Treasurer, by any two (2) directors, or by one (1) director, in the event that there is only one (1) director.

Section 10. Notice. Except as otherwise provided in the Restated Articles of Organization, special meetings of the board must be preceded by at least two (2) days' notice of the date, time and place of the meeting. The notice need not describe the purpose of the special meeting unless otherwise required by the Restated Articles of Organization or these ByLaws. All notices to directors shall conform to the requirements of Article IV.

Section 11. Waiver of Notice. Except as otherwise provided in the Restated Articles of Organization, a director may waive any notice before or after the date and time of the meeting. The waiver shall be in writing, signed by the director entitled to the notice, or in the form of an electronic transmission by the director to the Corporation, and filed with the minutes or corporate records. A director's attendance at or participation in a meeting waives any required notice to him or her of the meeting unless the director at the beginning of the meeting, or promptly upon his or her arrival, objects to holding the meeting or transacting business at the meeting and does not thereafter vote for or assent to action taken at the meeting.

Section 12. Quorum. Except as otherwise provided in the Restated Articles of Organization, a quorum of the board of directors consists of a majority of the directors then in office, provided always that any number of directors (whether one (1) or more and whether or not constituting a quorum) constituting a majority of directors present at any meeting or at any adjourned meeting may make any reasonable adjournment thereof.

Section 13. Action at Meeting. Except as otherwise provided in the Restated Articles of Organization, if a quorum is present when a vote is taken, the affirmative vote of a majority of directors present is the act of the board of directors. A director who is present at a meeting of the board of directors or a committee of the board of directors when corporate action is taken is considered to have assented to the action taken unless (a) he or she objects at the beginning of the meeting, or promptly upon his or her arrival, to holding it or transacting business at the meeting; (b) his or her dissent or abstention from the action taken is entered in the minutes of the meeting; or (c) he or she delivers written notice of his or her dissent or abstention to the presiding officer of the meeting before its adjournment or to the Corporation immediately after

adjournment of the meeting. The right of dissent or abstention is not available to a director who votes in favor of the action taken.

Section 14. Action Without Meeting. Except as otherwise provided in the Restated Articles of Organization, any action required or permitted to be taken by the directors may be taken without a meeting if the action is taken by the unanimous consent of the members of the board of directors. The action must be evidenced by one (1) or more consents describing the action taken, in writing, signed by each director, or delivered to the Corporation by electronic transmission, to the address specified by the Corporation for the purpose or, if no address has been specified, to the principal office of the Corporation, addressed to the Secretary or other officer or agent having custody of the records of proceedings of directors, and included in the minutes or filed with the corporate records reflecting the action taken. Action taken under this Section is effective when the last director signs or delivers the consent, unless the consent specifies a different effective date. A consent signed or delivered under this Section has the effect of a meeting vote for all purposes and may be described as such in any document.

Section 15. Telephone Conference Meetings. Except as otherwise provided in the Restated Articles of Organization, the board of directors or any committee thereof may permit any or all directors to participate in a regular or special meeting by, or conduct the meeting through the use of, any means of communication by which all directors participating may simultaneously hear each other during the meeting. A director participating in a meeting by this means is considered to be present in person at the meeting.

Section 16. Committees. Except as otherwise provided in the Restated Articles of Organization, the board of directors may create one (1) or more committees and appoint members of the board of directors to serve on them. Each committee may have one (1) or more members, who serve at the pleasure of the board of directors. The creation of a committee and appointment of members to it must be approved by a majority of all the directors in office when the action is taken. Article IV and Sections 10 through 15 of this Article shall apply to committees and their members. To the extent specified by the board of directors, each committee may exercise the authority of the board of directors. A committee may not, however (a) authorize distributions; (b) approve or propose to shareholders action that the MBCA requires be approved by shareholders; (c) change the number of the board of directors, remove directors from office or fill vacancies on the board of directors; (d) amend the Restated Articles of Organization; (e) adopt, amend or repeal ByLaws; or (f) authorize or approve reacquisition of shares, except according to a formula or method prescribed by the board of directors; or (g) take any other action pursuant to which authority may not be delegated under the MBCA.

Section 17. Compensation. Except as otherwise provided in the Restated Articles of Organization, the board of directors may fix the compensation of directors.

ARTICLE IV

MANNER OF NOTICE TO SHAREHOLDERS AND DIRECTORS

All notices hereunder shall conform to the following requirements:

(a) Notice shall be in writing unless oral notice is reasonable under the circumstances. Notice by electronic transmission is written notice.

(b) Notice may be communicated in person; by telephone, voice mail, telegraph, teletype, or other electronic means; by mail; by electronic transmission; or by messenger or delivery service. If these forms of personal notice are impracticable, notice may be communicated by a newspaper of general circulation in the area where published; or by radio, television, or other form of public broadcast communication.

(c) Written notice, other than notice by electronic transmission, if in a comprehensible form, is effective upon deposit in the United States mail, if mailed postpaid and correctly addressed to the shareholder's address shown in the Corporation's current record of shareholders.

(d) Written notice by electronic transmission, if in comprehensible form, is effective (1) if by facsimile telecommunication, when directed to a number furnished by the shareholder for the purpose; (2) if by electronic mail, when directed to an electronic mail address furnished by the shareholder for the purpose; (3) if by a posting on an electronic network together with separate notice to the shareholder of such specific posting, directed to an electronic mail address furnished by the shareholder for the purpose, upon the later of (i) such posting and (ii) the giving of such separate notice; or (4) if by any other form of electronic transmission, when directed to the shareholder in such manner as the shareholder shall have specified to the Corporation. An affidavit of the Secretary or an Assistant Secretary of the Corporation, the transfer agent or other agent of the Corporation that the notice has been given by a form of electronic transmission shall, in the absence of fraud, be prima facie evidence of the facts stated therein.

(e) Except as provided in subsection (c), written notice, other than notice by electronic transmission, if in a comprehensible form, is effective at the earliest of the following: (1) when received; (2) five (5) days after its deposit in the United States mail, if mailed postpaid and correctly addressed; (3) on the date shown on the return receipt, if sent by registered or certified mail, return receipt requested, or if sent by messenger or delivery service, on the date shown on the return receipt signed by or on behalf of the addressee; or (4) on the date of publication if notice by publication is permitted.

(f) Oral notice is effective when communicated if communicated in a comprehensible manner.

ARTICLE V

OFFICERS

Section 1. Enumeration. The Corporation shall have a President, a Treasurer, a Secretary and such other officers as may be appointed by the board of directors from time to time in accordance with these ByLaws. The board may appoint one (1) of its members to the office of Chairman of the board and from time to time define the powers and duties of that office notwithstanding any other provisions of these ByLaws.

Section 2. Appointment. The officers shall be appointed by the board of directors. A duly appointed officer may appoint one (1) or more officers or assistant officers if authorized by the board of directors. Each officer has the authority and shall perform the duties set forth in these ByLaws or, to the extent consistent with these ByLaws, the duties prescribed by the board of directors or by direction of an officer authorized by the board of directors to prescribe the duties of other officers.

Section 3. Qualification. The same individual may simultaneously hold more than one (1) office in the Corporation.

Section 4. Tenure. Officers shall hold office until the first meeting of the Directors following the next annual meeting of shareholders after their appointment and until their respective successors are duly appointed, unless a shorter or longer term is specified in the vote appointing them.

Section 5. Resignation. An officer may resign at any time by delivering notice of the resignation to the Corporation. A resignation is effective when the notice is delivered unless the notice specifies a later effective date. If a resignation is made effective at a later date and the Corporation accepts the future effective date, the board of directors may fill the pending vacancy before the effective date if the board of directors provides that the successor shall not take office until the effective date. An officer's resignation shall not affect the Corporation's contract rights, if any, with the officer.

Section 6. Removal. The board of directors may remove any officer at any time with or without cause. The appointment of an officer shall not itself create contract rights. An officer's removal shall not affect the officer's contract rights, if any, with the Corporation.

Section 7. President. The President when present shall preside at all meetings of the shareholders and, if there is no Chairman of the board of directors, of the Directors. He or she shall be the chief executive officer of the Corporation except as the board of directors may otherwise provide. The President shall perform such duties and have such powers additional to the foregoing as the Directors shall designate.

Section 8. Treasurer. The Treasurer shall, subject to the direction of the Directors, have general charge of the financial affairs of the Corporation and shall cause to be kept accurate books of accounts. He or she shall have custody of all funds, securities, and valuable documents of the Corporation, except as the Directors may otherwise provide. The Treasurer shall perform such duties and have such powers additional to the foregoing as the Directors may designate.

Section 9. Secretary. The Secretary shall have responsibility for preparing minutes of the Directors' and shareholders' meetings and for authenticating records of the Corporation. The Secretary shall perform such duties and have such powers additional to the foregoing as the Directors shall designate.

ARTICLE VI

PROVISIONS RELATING TO SHARES AND OTHER PROVISIONS

Section 1. Share Certificates. Each shareholder shall be entitled to a share certificate in such form as is prescribed by law and approved from time to time by the board of directors. The certificates shall be signed by the President or any Vice President and by the Treasurer or any Assistant Treasurer. Such signatures may be facsimiles. If any officer who has signed or whose facsimile signature has been placed on such certificate no longer holds office when the certificate is issued, the certificate shall nevertheless be valid.

Section 2. Transfer of Shares. Subject to restrictions, if any, imposed by the Amended and Restated Shareholders Agreement, the Restated Articles of Organization then in effect, or these ByLaws, title to a share certificate and to the shares represented thereby shall be transferred only by delivery of the certificate properly endorsed, or by delivery of the certificate accompanied by a written assignment of shares represented by such certificate, or a written power of attorney to sell, assign, or transfer the certificate or the shares represented thereby, properly executed. The person registered in the records of the corporation as the owner of shares shall have the exclusive right to receive dividends thereon and to vote thereon as such owner, shall be held liable for such calls and assessments, if any, as may lawfully be made thereon, and, except only as may be required by law, may in all respects be treated by the corporation as the exclusive owner thereof unless and to the extent that the corporation has established a procedure by which the beneficial owner of shares that are registered in the name of a nominee will be recognized by the corporation as the shareholder.

Section 3. Transfer Records. Unless a transfer agent is appointed, the Secretary shall keep or cause to be kept, at the principal office of the corporation or at the office of the Secretary, the share and transfer records of the corporation, in which are contained the names of all shareholders and the record address and the amount of shares held by each. The transfer records of the shares of the corporation may be closed for such period from time to time in anticipation of shareholders' meetings or the declaration or payment of dividends as the board of directors may determine.

Section 4. Lost or Destroyed Certificates. In case of the alleged loss, destruction, or mutilation of a share certificate, a new share certificate may be issued in place of the lost, destroyed, or mutilated certificate upon such terms as the board of directors may determine.

Section 5. Voting of Securities. Except as the board of directors may otherwise designate, the President may waive notice of, or vote for this corporation or appoint any person or persons to act as proxy or attorney-in-fact for this corporation with or without power of substitution at, any meeting of shareholders of any other corporation or organization, the securities of which may be held by this corporation.

ARTICLE VII
INDEMNIFICATION

Section 1. Definitions. In this Article VII the following words shall have the following meanings unless the context requires otherwise:

“Corporation” includes any domestic or foreign predecessor entity of the Corporation in a merger.

“Director” or “Officer” means an individual who is or was a director or officer, respectively, of the Corporation or who, while a Director or Officer of the Corporation, is or was serving at the Corporation's request as a director, officer, partner, trustee, employee, or agent of another domestic or foreign corporation, partnership, joint venture, trust, employee benefit plan, or other entity. A Director or Officer is considered to be serving an employee benefit plan at the Corporation's request if his or her duties to the Corporation also impose duties on, or otherwise involve services by, him or her to the plan or to participants in or beneficiaries of the plan. “Director” or “Officer” includes, unless the context requires otherwise, the estate or personal representative of a Director or Officer.

“Disinterested Director” means a Director who, at the time of a vote or selection referred to in Section 4 of this Article VII, is not (i) a Party to the Proceeding, or (ii) an individual having a familial, financial, professional, or employment relationship with the Director whose indemnification or advance for expenses is the subject of the decision being made, which relationship would, in the circumstances, reasonably be expected to exert an influence on the Director's judgment when voting on the decision being made.

“Expenses” includes counsel fees.

“Liability” means the obligation to pay a judgment, settlement, penalty or fine, including an excise tax assessed with respect to an employee benefit plan, or reasonable expenses incurred with respect to a proceeding.

“Party” means an individual who was, is, or is threatened to be made a defendant or respondent in a Proceeding.

“Proceeding” means any threatened, pending, or completed action, suit, or proceeding, whether civil, criminal, administrative, arbitrative, or investigative, and whether formal or informal.

Section 2. Indemnification of directors and officers.

(a) Except as otherwise provided in this Section, the Corporation shall indemnify to the fullest extent permitted by law an individual who is a Party to a Proceeding, because he or she is a Director or Officer, against Liability incurred in the Proceeding if (1) (i) he or she conducted himself or herself in good faith; and (ii) he or she reasonably believed that his or her conduct was in the best interests of the Corporation or that his or her conduct was at least not opposed to the best interests of the Corporation; and (iii) in the case of any criminal Proceeding,

he or she had no reasonable cause to believe his or her conduct was unlawful; or (2) he or she engaged in conduct for which he or she shall not be liable under a provision of the Restated Articles of Organization authorized by Section 2.02(b)(4) of MBCA or any successor provision to such Section.

(b) A Director's or Officer's conduct with respect to an employee benefit plan for a purpose he or she reasonably believed to be in the interests of the participants in, and the beneficiaries of, the plan is conduct that satisfies the requirement that his or her conduct was at least not opposed to the best interests of the Corporation.

(c) The termination of a Proceeding by judgment, order, settlement, or conviction, or upon a plea of nolo contendere or its equivalent, is not, of itself, determinative that the Director or Officer did not meet the relevant standard of conduct described in this Section.

(d) Unless ordered by a court, the Corporation may not indemnify a Director or Officer under this Section if his or her conduct did not satisfy the standards set forth in subsection (a) or subsection (b) of this Section 2.

Section 3. Advance for Expenses. The Corporation shall, before final disposition of a Proceeding, advance funds to pay for or reimburse the reasonable Expenses incurred by a Director or Officer who is a party to a Proceeding, because he or she is a Director or Officer, if he or she delivers to the Corporation

(a) a written affirmation of his or her good faith belief that he or she has met the relevant standard of conduct described in Section 2 of this Article VII or that the proceeding involves conduct for which Liability has been eliminated under a provision of the Restated Articles of Organization as authorized by Section 2.02(b)(4) of the MBCA or any successor provision to such Section; and

(b) his or her written undertaking to repay any funds advanced if he or she is not wholly successful, on the merits or otherwise, in the defense of such Proceeding and it is ultimately determined pursuant to Section 4 of this Article VII or by a court of competent jurisdiction that he or she has not met the relevant standard of conduct described in Section 2 of this Article VII. Such undertaking must be an unlimited general obligation of the Director or Officer but need not be secured and shall be accepted without reference to the financial ability of the Director or Officer to make repayment.

Section 4. Determination of Indemnification. The determination of whether a Director or Officer has met the relevant standard of conduct set forth in Section 2 to permit indemnification shall be made

(a) if there are two (2) or more Disinterested Directors, by the board of directors by a majority vote of all the Disinterested Directors, a majority of whom shall for such purpose constitute a quorum, or by a majority of the members of a committee of two or more Disinterested Directors appointed by vote;

(b) by special legal counsel (1) selected in the manner prescribed in clause (a); or (2) if there are fewer than two (2) Disinterested Directors, selected by the board of directors, in which selection Directors who do not qualify as Disinterested Directors may participate; or

(c) by the shareholders entitled to vote, but shares owned by or voted under the control of a Director who at the time does not qualify as a Disinterested Director may not be voted on the determination.

Section 5. Notification and Defense of Claim; Settlements.

(a) In addition to and without limiting the foregoing provisions of this Article VII and except to the extent otherwise required by law, it shall be a condition of the Corporation's obligation to indemnify under Section 2 of this Article VII (in addition to any other condition provided in these ByLaws or by law) that the person asserting, or proposing to assert, the right to be indemnified, must notify the Corporation in writing as soon as practicable of any action, suit, proceeding or investigation involving such person for which indemnity will or could be sought, but the failure to so notify shall not affect the Corporation's obligation to indemnify except to the extent the Corporation is adversely affected thereby. With respect to any Proceeding of which the Corporation is so notified, the Corporation will be entitled to participate therein at its own expense and/or to assume the defense thereof at its own expense, with legal counsel reasonably acceptable to such person. After notice from the Corporation to such person of its election so to assume such defense, the Corporation shall not be liable to such person for any legal or other Expenses subsequently incurred by such person in connection with such action, suit, proceeding or investigation other than as provided below in this subsection (a). Such person shall have the right to employ his or her own counsel in connection with such action, suit, proceeding or investigation, but the fees and Expenses of such counsel incurred after notice from the Corporation of its assumption of the defense thereof shall be at the expense of such person unless (1) the employment of counsel by such person has been authorized by the Corporation, (2) counsel to such person shall have reasonably concluded that there may be a conflict of interest or position on any significant issue between the Corporation and such person in the conduct of the defense of such action, suit, proceeding or investigation, or (3) the Corporation shall not in fact have employed counsel to assume the defense of such action, suit, proceeding or investigation, in each of which cases the fees and Expenses of counsel for such person shall be at the expense of the Corporation, except as otherwise expressly provided by this Article VII. The Corporation shall not be entitled, without the consent of such person, to assume the defense of any claim brought by or in the right of the Corporation or as to which counsel for such person shall have reasonably made the conclusion provided for in clause (2) above.

(b) The Corporation shall not be required to indemnify such person under this Article VII for any amounts paid in settlement of any Proceeding unless authorized in the same manner as the determination that indemnification is permissible under Section 4 of this Article VII, except that if there are fewer than two (2) Disinterested Directors, authorization of indemnification shall be made by the board of directors, in which authorization Directors who do not qualify as Disinterested Directors may participate. The Corporation shall not settle any action, suit, proceeding or investigation in any manner which would impose any penalty or limitation on such person without such person's written consent. Neither the Corporation nor such person will unreasonably withhold their consent to any proposed settlement.

Section 6. Insurance. The Corporation may purchase and maintain insurance on behalf of an individual who is a Director or Officer of the Corporation, or who, while a Director or Officer of the Corporation, serves at the Corporation's request as a director, officer, partner, trustee, employee, or agent of another domestic or foreign corporation, partnership, joint venture, trust, employee benefit plan, or other entity, against Liability asserted against or incurred by him or her in that capacity or arising from his or her status as a Director or Officer, whether or not the Corporation would have power to indemnify or advance Expenses to him or her against the same Liability under this Article VII.

Section 7. Application of this Article VII.

(a) The Corporation shall not be obligated to indemnify or advance Expenses to a Director or Officer of a predecessor of the Corporation, pertaining to conduct with respect to the predecessor, unless otherwise specifically provided.

(b) This Article VII shall not limit the Corporation's power to (1) pay or reimburse Expenses incurred by a Director or an Officer in connection with his or her appearance as a witness in a proceeding at a time when he or she is not a Party or (2) indemnify, advance Expenses to, or provide or maintain insurance on behalf of an employee or agent.

(c) The indemnification and advancement of Expenses provided by, or granted pursuant to, this Article VII shall not be considered exclusive of any other rights to which those seeking indemnification or advancement of Expenses may be entitled.

(d) Each person who is or becomes a Director or Officer shall be deemed to have served or to have continued to serve in such capacity in reliance upon the indemnity provided for in this Article VII. All rights to indemnification under this Article VII shall be deemed to be provided by a contract between the Corporation and the person who serves as a Director or Officer of the corporation at any time while this Article VII and the relevant provisions of the MBCA are in effect. Any repeal or modification thereof shall not affect any rights or obligations then existing.

(e) If the laws of the Commonwealth of Massachusetts are hereafter amended from time to time to increase the scope of permitted indemnification, indemnification hereunder shall be provided to the fullest extent permitted or required by any such amendment.

ARTICLE VIII

FISCAL YEAR

Except as from time to time otherwise determined, the fiscal year of the Corporation shall be the year ending with December 31 in each year.

ARTICLE IX

AMENDMENTS

These ByLaws may be amended or repealed by the shareholders entitled to vote. If authorized by the Restated Articles of Organization, the board of directors may also make, amend, or repeal these ByLaws in whole or in part, except with respect to this Section and any provision of these ByLaws which, by an express provision in the MBCA, the Restated Articles of Organization, or these ByLaws, requires action by the shareholders. Not later than the time of giving notice of the meeting of shareholders next following the making, amending, or repealing by the board of directors of any By-law, notice stating the substance of the action taken by the board of directors shall be given to all shareholders entitled to vote on amending the ByLaws. Any action taken by the board of directors with respect to these ByLaws may be amended or repealed by the shareholders.

NOTWITHSTANDING ANY PROVISION OF THESE AMENDED AND RESTATED BYLAWS OR THE RESTATED ARTICLES OF ORGANIZATION, THAT CERTAIN AMENDED AND RESTATED SHAREHOLDERS AGREEMENT EFFECTIVE NOVEMBER 9, 2018 BY AND BETWEEN THE SHAREHOLDERS AND SHAREHOLDERS JOINING THEREIN SHALL HAVE FULL FORCE AND EFFECT. IN THE EVENT OF A CONFLICT, THE PROVISIONS OF SAID SHAREHOLDERS AGREEMENT SHALL CONTROL.

4833-8603-6089, v. 1



CERTIFICATE OF GOOD STANDING AND/OR TAX COMPLIANCE



LIBERTY COMPASSION INC
10 GREENE ST
PROVIDENCE RI 02903-3232

Why did I receive this notice?

The Commissioner of Revenue certifies that, as of the date of this certificate, LIBERTY COMPASSION INC is in compliance with its tax obligations under Chapter 62C of the Massachusetts General Laws.

This certificate doesn't certify that the taxpayer is compliant in taxes such as unemployment insurance administered by agencies other than the Department of Revenue, or taxes under any other provisions of law.

This is not a waiver of lien issued under Chapter 62C, section 52 of the Massachusetts General Laws.

What if I have questions?

If you have questions, call us at (617) 887-6400 or toll-free in Massachusetts at (800) 392-6089, Monday through Friday, 8:30 a.m. to 4:30 p.m..

Visit us online!

Visit mass.gov/dor to learn more about Massachusetts tax laws and DOR policies and procedures, including your Taxpayer Bill of Rights, and MassTaxConnect for easy access to your account:

- Review or update your account
- Contact us using e-message
- Sign up for e-billing to save paper
- Make payments or set up autopay

Edward W. Coyle, Jr., Chief
Collections Bureau

000032



William Francis Galvin
Secretary of the
Commonwealth

The Commonwealth of Massachusetts
Secretary of the Commonwealth
State House, Boston, Massachusetts 02133

Date: September 16, 2019

To Whom It May Concern :

I hereby certify that according to the records of this office,

LIBERTY COMPASSION, INC.

is a domestic corporation organized on **August 01, 2018** , under the General Laws of the Commonwealth of Massachusetts. I further certify that there are no proceedings presently pending under the Massachusetts General Laws Chapter 156D section 14.21 for said corporation's dissolution; that articles of dissolution have not been filed by said corporation; that, said corporation has filed all annual reports, and paid all fees with respect to such reports, and so far as appears of record said corporation has legal existence and is in good standing with this office.



In testimony of which,
I have hereunto affixed the
Great Seal of the Commonwealth
on the date first above written.

William Francis Galvin

Secretary of the Commonwealth

Certificate Number: 19090318120

Verify this Certificate at: <http://corp.sec.state.ma.us/CorpWeb/Certificates/Verify.aspx>

Processed by:

Diversity Plan

Liberty Compassion, Inc. (“Liberty”) is committed to promoting equity in its operations for diverse populations, which the Cannabis Control Commission (the “CCC” or “Commission”) has defined as the following demographics:

1. Minorities
2. Women
3. Veterans
4. People with Disabilities
5. People of LGBTQ+

To support such populations, Liberty has created the following Diversity Plan. This Diversity Plan will outline the Goals, Programs, and Measurements to promote equity at Liberty.

Goals

In order for Liberty to promote equity for the aforementioned demographics in its operations, Liberty has established the following goals:

1. Increasing the number of individuals falling into the above-listed demographics working in the establishment and providing training and tools to ensure their success; and
2. Providing access for and assisting individuals falling into the above-listed demographics to achieve their goal of entering the adult-use marijuana industry.

Programs

Liberty has developed specific programs to reach its stated goals to promote diversity and equity in its operations. These programs will include:

1. Advertising employment opportunities in diverse publications or other mediums as positions become available. More specifically, job postings on diversityjobs.com, veteranjoblistings.com, vetjobs.com, alllgbtjobs.com, and pink-jobs.com;
2. Advertising employment opportunities tailored to individuals falling into the above-listed demographics with local career centers (e.g. the MassHire Central Career Center) and partnering with local organizations (e.g. the Nashoba Chamber of Commerce) to reach diverse communities;
3. Distributing an internal memo that encourages current employees to recommend individuals falling into the above-listed demographics for employment at Liberty;
4. Annually attending or hosting a job fair or hiring event specifically targeted to diverse applicants (e.g. the Boston Bilingual and Diversity Job Fair, RecruitMilitary)
5. Providing semi-annual training for employees falling into the above-listed demographics to promote their advancement within the marijuana industry; trainings will cover topics such as

building customer service skills and developing coaching and management techniques. All-company diversity seminars will also be offered, advised by employees from the above-listed demographics.

6. Providing semi-annual trainings for individuals falling in to the above-listed demographics to promote entry into the marijuana industry and advancement. Trainings will include topics such as skills for dispensary employment, resume and cover letter writing, interviewing, and management skills.

Measurements

Liberty has outlined methods in which the goals and programs will be tracked and measured for success. Human Resources will administer this Diversity Plan and will be responsible for measuring and reporting outcomes to ensure Liberty continues to meet its commitments. Measuring the success of the program is critical to ensure Liberty continues to meet its commitments and is able to accurately report to the Commission.

Measurable outcomes include:

- Recording and tracking the percentages of Liberty's employees falling into the above-listed demographics (opt-in) and regularly reviewing the percentages against the adult population demographic percentages in Massachusetts and specifically, Fitchburg and areas of Worcester, the closest areas of disproportionate impact;
- Liberty commits to achieve and maintain a workforce with at least 25% of which are from the above demographics (minorities, women, veterans, people with disabilities, or people of all gender identities and sexual orientations)
- Documenting the number of postings in diverse mediums and career centers and demographic information related to those mediums, as available;
- Documenting the number of internal communications sent toward recruiting diverse candidates;
- Recording the number of job fairs or hiring events attended or hosted, specifically targeted to diverse candidates;
- Documenting the subject matter of trainings and information sessions held and the number of individuals falling into the above listed demographics in attendance; and
- Recording and reviewing the amount of money spent on advertising, events, and training.

Human Resources and Accounting will review and evaluate Liberty's measurable outcomes no less than bi-annually to ensure that Liberty is meeting its stated commitments. Liberty will submit the outcomes of this Plan's progress and success to the Commission upon yearly renewal of the license.

In the event that Liberty is not meeting its stated commitments, Liberty will solicit company-wide input on the Plan and diversity related initiatives.

In execution of its Diversity Plan, Liberty will adhere to the requirements set forth in 935 CMR 500.105(4) which provides the permitted and prohibited advertising, branding, marketing, and sponsorship practices of Marijuana Establishments. Any actions taken, or programs instituted by Liberty will not violate the Commission's regulations with respect to limitations on ownership or control or other applicable state laws.

Liberty Compassion Maintaining of Financial Records Policies and Procedures

Liberty Compassion, Inc. (“Liberty Compassion”) maintains operating policies and procedures that ensure financial records are accurate and maintained in compliance with state regulations. Financial information is maintained on the accrual basis in accordance with Generally Accepted Accounting Principles (“GAAP”).

Liberty Compassion ensures that both Liberty Compassion’s and personal confidential financial information are secure and accurate. Financial information is maintained in a secure location and will not be disclosed without authorization or unless required by law or regulations or pursuant to a court order. To ensure accuracy, security and data integrity, Liberty Compassion utilizes several procedures:

1. **Recordkeeping:** Liberty Compassion will maintain business records compliant with the regulations set forth in 935 CMR 500. These records along with any other records outlined in 935 CMR 500 will be immediately available to the Cannabis Control Commission (“Commission” or “CCC”) upon request. Business and financial records will be maintained in accordance with Generally Accepted Accounting Principles (GAAP), and in an audit friendly format. Manual or computerized financial records maintained by Liberty Compassion include but are not limited to:
 - Assets and liabilities;
 - Monetary transactions;
 - Books of accounts which include journals, ledgers, and supporting documents, agreements, checks, invoices and vouchers;
 - Sales records including the quantity, form and cost of marijuana products; and
 - Salary and wages paid to each employee, stipend paid to each board member, and any executive compensation, bonus, benefit, or item of value paid to any individual affiliated with Liberty Compassion.

Liberty Compassion maintains accounting records in QuickBooks. This system supports detailed transaction data for Company purchases, inventory valuation, revenue and payroll. QuickBooks is securely hosted. System access is limited to users with need and each user has security settings specific to their role. Every transaction the company makes will go through the accounting software thus guaranteeing complete reporting. Bank accounts will be reconciled monthly and month-end financials are reviewed by management each month.

2. **Accounting Review:** Liberty Compassion will engage with a third-party accounting firm to review annual financial reports for compliance with GAAP.

3. **Tax:** Liberty Compassion will engage with a third-party tax service to prepare and file federal, state and other tax returns to ensure compliance.

Per the closure of the Liberty Compassion cultivation facility, all records including business and financial records, will be maintained securely and paid for by Liberty Compassion.

Liberty Compassion will comply with all sales recording requirements, including:

- Using a point-of-sale (POS) system approved by the Commission, in consultation with the Massachusetts Department of Revenue (the “DOR”), and a sales recording module approved by the DOR;
- Conducting monthly analyses of its equipment and sales data, and maintaining records, available to the Commission upon request, that the monthly analysis has been performed;
- Complying with 830 CMR 62C.25.1: *Record Retention* and DOR Directive 16-1 regarding recordkeeping requirements;
- Separate accounting practices at the point-of-sale for marijuana and non-marijuana sales;
- Maintaining such records that would allow for the Commission and the DOR to audit and examine the point-of-sale system used in order to ensure compliance with Massachusetts tax laws and state regulations; and
- Maintaining and providing the Commission on a biannual basis accurate retail sales data collected during the preceding six (6) months to ensure an adequate supply of medical marijuana and marijuana products.

Not in limitation of the foregoing, we will not utilize software or other methods to manipulate or alter any sales data. We shall conduct a monthly analysis of our equipment and sales daily to determine that no software has been installed that could be used to manipulate or alter sales data and that no other methodology has been employed to manipulate or alter sales data. We shall maintain records that we have performed the monthly analysis and we will produce it upon request by the Commission. If we determine that software has been installed for the purpose of manipulation or alteration of sales data or other methods have been utilized to manipulate or alter sales data, we shall: immediately disclose the information to the Commission; cooperate with the Commission in any investigation regarding manipulation or alteration of sales data; and we shall take other action, directed by the Commission, to comply with 935 CMR 500.105.

Liberty Compassion will also securely maintain written financial records of: (1) compliance with liability insurance coverage or maintenance of escrow requirements and all bond or escrow requirements and (2) all fees, fines, and penalties paid under state regulations and other applicable sections of the regulations.

Liberty Compassion Personnel Policies, including Background Checks Policies & Procedures

Marijuana Establishment Agent Personnel Records

Personnel records for each agent will be maintained for at least twelve (12) months after termination of the agent's affiliation with Liberty Compassion and will include, at a minimum, the following:

- All materials submitted to the Commission pursuant to 935 CMR 500.030(2)
- Documentation of verification of references
- Results of initial background investigation, including CORI reports
- Signed employment agreement
- A job description including duties, authority, responsibilities, qualifications, and supervision
- Documentation of all required training, including training regarding privacy and confidentiality requirements, and the signed statement of the individual indicating the date, time, and place he or she received said training and the topics discussed, including the name and title of presenters
- Notice of completed responsible vendor and eight-hour related duty training
- Documentation of periodic performance evaluations
- Documentation of all security related events (including violations) and the results of any investigations and description of remedial actions, restrictions, or additional training required as a result of an incident
- Record of any disciplinary action taken

Personnel records will be kept in a secure location to maintain confidentiality and will only be accessible to the agent's manager or members of the executive management team.

Staffing Plan

Liberty Compassion's Chief Executive Officer and Management Team will routinely review staffing levels and requirements to determine if vacancies are anticipated and whether specific positions need to be created in response to company needs. Liberty Compassion's personnel practices will comply with the following, which will apply to all types of employment situations, including, but not limited to, hiring, terminations, promotions, training, wages and benefits:

- State anti-discrimination statutes and Equal Employment Opportunity Commission (EEOC) requirements
- Liberty Compassion's Diversity Plan and Community Initiatives
- Liberty Compassion's Plan to Positively Impact Areas of Disproportionate Impact

- Background and Reference Checks
- Mandatory reporting of criminal convictions (and termination if necessary)
- State and Federal Family Leave Act
- Workplace Safety Laws
- Workers' Compensation
- State and Federal Minimum Wage Requirements
- Non-Disclosure and Non-Complete Agreements
- Any other applicable local, state, or federal employment laws, rules, or regulations

Liberty Compassion is dedicated to hiring Clinton residents, residents of the City of Fitchburg, and in areas of disproportionate impact within Worcester when possible.

Accessible Business Hours

Liberty Compassion Retail Facilities will be open up to 12 hours per day (typically 8:00am – 8:00pm), subject to approval by local and regulatory authorities. Security personnel will be on hand at least 30 minutes prior to opening and 30 minutes after closing, to ensure employee safety and compliance with all local regulations.

The Liberty Compassion Cultivation and Manufacturing Facility will be open 12-15 hours per day, typically with light staffing later in the day. Security personnel will be on hand during facility business hours to ensure employee safety and facility oversight.

Work schedules will be either part-time, full-time, or salaried, depending of the specific position. Schedules will be set according to the needs of each department as determined by the department manager and the executive manager they report to. It is the department manager's responsibility to develop and implement a work schedule that provides necessary duty and personnel coverage but does not exceed what is required for full implementation of operations. It is also the department manager's responsibility to ensure that adequate coverage occurs on a daily basis and does not lead to unnecessary utilization of overtime coverage, or employee overuse.

Employee hours will be well communicated to and coordinated with prospective employees, to help ensure appropriate coverage to support customer needs and balanced schedules to support employees' lives.

Personnel Policies & Procedures

Liberty Compassion's written policies may address topics including, but not limited to:

- Personnel policies
- Family and Medical Leave Act (FMLA)
- Consolidated Omnibus Budget Reconciliation Act (COBRA)
- Employee Retirement Income Security Act (ERISA)

- Workers' compensation
- Equal employment opportunity
- 935 CMR 500.000 and updates
- Discrimination
- Harassment
- Disabilities
- Privacy / HIPAA / Maintenance of personnel files
- Holidays
- Working Hours / Overtime
- Sick / Personal time
- Performance reviews
- Disciplinary procedures
- Leaves of absence

In addition to the above, Liberty Compassion holds marijuana establishment agents to the highest standards of professionalism while offering a multitude of opportunities and/or benefits, including but not limited to: fair and equal compensation and employment, and protection from discrimination based on any status enumerated under the laws enforced by federal EEOC or under the labor laws of the Commonwealth; ethical and respectful workplace conduct, and prohibition of workplace violence, intimidation or harassment; fair and appropriate compensation, along with benefits such as health insurance, paid time off, overtime and performance bonuses, workers compensation, and various forms of compensated personal and family medical leave; workplace safety standards promulgated by US OSHA and Massachusetts division of occupational safety; prioritization and advancement of existing cultivating agents upon the availability of positions within the marijuana establishment; and performance-based evaluations conducted at least annually, as part of our effort to support marijuana establishment agents' advancement, productivity and career objectives. We will ensure that all marijuana establishment agents are qualified for their role and complete training prior to performing job functions. Training shall be tailored to the roles and responsibilities of the job function of each marijuana establishment agent, and at a minimum must include a Responsible Vendor Program under 935 CMR 500.105(2)(b). At a minimum, staff shall receive eight hours of on-going training annually. All current owners, managers and employees of Liberty Compassion that are involved in the handling and sale of marijuana for adult use at the time of licensure or renewal of licensure, as applicable, will have attended and successfully completed a responsible vendor program. We will maintain records of responsible vendor training program compliance for four years and make them available to inspection by the Commission and any other applicable licensing authority upon request during normal business hours. We will prepare an alcohol, smoke, and drug-free workplace policy as well as a plan describing how confidential information will be maintained. We will also establish a policy for the immediate dismissal of any marijuana establishment agent who has: (a) diverted marijuana, which shall be reported to law enforcement officials and to the Commission; (b) engaged in unsafe practices with regard to operation of the Marijuana Establishment, which shall be reported to the Commission; or (c) been convicted or entered a guilty plea, plea of *nolo contendere*, or admission to sufficient facts of a felony drug offense involving distribution to a minor in the Commonwealth, or a like violation of the laws of another

state, the United States or a foreign jurisdiction, or a military, territorial, or Native American tribal authority.

Agent Background Checks

- In addition to completing the Commission's agent registration process, all agents hired to work for Liberty Compassion will undergo a detailed background investigation prior to being granted access to a Liberty Compassion facility or beginning work duties.
- Background checks will be conducted on all agents in their capacity as employees or volunteers for Liberty Compassion pursuant to 935 CMR 500.100 and will be used by the Director of Security, who will be registered with the Department of Criminal Justice Information Systems pursuant to 803 CMR 2.04: iCORI Registration and the Commission for purposes of determining the suitability of individuals for registration as a marijuana establishment agent with the licensee.
- For purposes of determining suitability based on background checks performed in accordance with 935 CMR 500.101(1), Liberty Compassion will consider:
 - a. All conditions, offenses, and violations are construed to include Massachusetts law or like or similar law(s) of another state, the United States or foreign jurisdiction, a military, territorial or Native American tribal authority, or any other jurisdiction.
 - b. All criminal disqualifying conditions, offenses, and violations include the crimes of attempt, accessory, conspiracy, and solicitation. Juvenile dispositions will not be considered as a factor for determining suitability.
 - c. Where applicable, all look back periods for criminal conditions, offenses, and violations included in 935 CMR 500.802 commence upon the date of disposition; provided, however, that if disposition results in incarceration in any institution, the look back period will commence upon release from incarceration.
- Suitability determinations will be made in accordance with the procedures set forth in 935 CMR 500.800. In addition to the requirements established in 935 CMR 500.800, Liberty Compassion will:
 - a. Comply with all guidance provided by the Commission and 935 CMR 500.802: Tables B through D to determine if the results of the background are grounds for Mandatory Disqualification or Presumptive Negative Suitability Determination.
 - b. Consider whether offense(s) or information that would result in a Presumptive Negative Suitability Determination under 935 CMR 500.802. In the event a Presumptive Negative Suitability Determination is made, Liberty Compassion will consider the following factors:
 - i Time since the offense or incident
 - ii Age of the subject at the time of the offense or incident

- iii Nature and specific circumstances of the offense or incident
- iv Sentence imposed and length, if any, of incarceration, if criminal
- v Penalty or discipline imposed, including damages awarded, if civil or administrative
- vi Relationship of offense or incident to nature of work to be performed
- vii Number of offenses or incidents
- viii Whether offenses or incidents were committed in association with dependence on drugs or alcohol from which the subject has since recovered
- ix If criminal, any relevant evidence of rehabilitation or lack thereof, such as information about compliance with conditions of parole or probation, including orders of no contact with victims and witnesses, and the subject's conduct and experience since the time of the offense including, but not limited to, professional or educational certifications obtained
- x Any other relevant information, including information submitted by the subject.

c. Consider appeals of determinations of unsuitability based on claims of erroneous information received as part of the background check during the application process in accordance with 803 CMR 2.17: Requirement to Maintain a Secondary Dissemination Log and 2.18: Adverse Employment Decision Based on CORI or Other Types of Criminal History Information Received from a Source Other than the DCJIS.

- Upon adverse determination, Liberty Compassion will provide the applicant a copy of their background screening report and a pre-adverse determination letter providing the applicant with a copy of their right to dispute the contents of the report, who to contact to do so and the opportunity to provide a supplemental statement
- After 10 business days, if the applicant is not disputing the contents of the report and any provided statement does not alter the suitability determination, an adverse action letter will be issued providing the applicant information on the final determination made by Liberty Compassion along with any legal notices required
- All suitability determinations will be documented in compliance with all requirements set forth in 935 CMR 500 and guidance provided by the Commission.
- Background screening will be conducted by an investigative firm holding the National Association of Professional Background Screeners (NAPBS®) Background Screening Credentialing Council (BSCC) accreditation and capable of performing the searches required by the regulations and guidance provided by the Commission
- References provided by the agent will be verified at the time of hire

- As deemed necessary, individuals in key positions with unique and sensitive access (e.g. members of the executive management team) will undergo additional screening, which may include interviews with prior employers or colleagues
- As a condition of their continued employment, agents, volunteers, contractors, and subcontractors are required to renew their Program ID cards annually and submit to other background screening as may be required by Liberty Compassion or the Commission

Liberty Compassion Qualifications and Training Policies & Procedures

Liberty Compassion will ensure that all employees of Liberty Compassion are qualified to work as a marijuana establishment agent and will be properly trained to serve in their respective role in the organization in compliance with all state and Cannabis Control Commission (“Commission”) regulations.

Qualifications

Candidates for employment at Liberty Compassion must be 21 years of age or older and must not have been convicted of a criminal offense in the Commonwealth involving the distribution of a controlled substance to minors, or a like violation of the laws of another state, the United States, or foreign jurisdiction, or a military, territorial, or Native American tribal authority. Liberty Compassion will also ensure that its employees are suitable for registration consistent with provisions of 935 CMR 500.802. If Liberty Compassion discovers that any of its agents are not suitable for registration, the agent’s employment will be terminated and Liberty Compassion will notify the Commission within one (1) business day that the agent is no longer associated with the company.

Training

After completing applicable background checks, Liberty Compassion, Inc. (“Liberty Compassion”) will hire new employees on a probationary basis. During this probationary period, employees will complete a comprehensive training program and will be evaluated for suitability in a restricted-access environment. Training will be customized based on the role of the employee and will include, at minimum, a Responsible Vendor Program. Prior to performing any job functions, employees will learn the responsibilities of their position and how the position operates on a daily basis. A component of this part of training is done in a shadowing context. New hires will spend time observing activities performed by current agents and their direct supervisor in their department. New hires will be able to observe tasks, activities and responsibilities of their position and will be able to ask questions. Liberty Compassion ensures that all hired staff will complete applicable training prior to performing job functions. Training will be held on-site and will cover the following:

1. Health and Sanitation;
2. Legal Compliance;
3. Safety and Security;
4. Inventory Monitoring and Reporting/Recordkeeping;
5. Marijuana Product Education; and
6. Job Specific Roles.

Annual Training

Pursuant to 935 CMR 500.105(2)(a), Liberty Compassion maintains that all its agents receive at least eight hours of on-going training annually. This training will cover a variety of topics ranging from updated laws and regulations to cannabis education. The Director of Operations is ultimately responsible for the topics covered in annual on-going training and is assisted by the Human Resources Manager who is ultimately responsible for ensuring all Liberty Compassion agents complete annual training. Liberty Compassion will utilize both internal and external experts and professionals in fostering on-going training. On-going training will be recorded and stored along with an individual's personnel records.

Responsible Vendor Training

Before commencing operations, all current owners, manager, and employees with Liberty Compassion will have attended and successfully completed a responsible vendor program. Once all agents have successfully attended and completed a responsible vendor program, Liberty Compassion will be designated as "responsible vendor", a status Liberty Compassion will maintain so long as operations continue. All new employees of Liberty Compassion will also participate in a responsible vendor training program within their first 90 days of service to maintain Liberty Compassion's status as a responsible vendor. Once an agent has completed a responsible vendor training program, they must complete the program annually to ensure Liberty Compassion maintains status as a responsible vendor. Liberty Compassion will maintain records of Responsible Vendor Training compliance for at least 4 years. Administrative employees who do not handle or sell marijuana may take the Responsible Vendor program voluntarily.

Certification training program standards will be characterized by the following:

1. No owner or employee of a responsible vendor program will have an interest in Liberty Compassion;
2. Program providers will submit their programs to the Commission every two years for approval as a responsible vendor program;
3. The program shall include at least two hours of instruction time;
4. The program will be taught in a real-time, interactive classroom setting where the instructor is able to verify the identification of each individual attending the program and certify completion of the program by the individual identified;
5. The program provider will maintain its training records at its principal place of business during the applicable year and for the following three years;
6. The provider will make the records available for inspection by the Commission and any other applicable licensing authority upon request during normal business hours;

7. The program will provide written documentation of attendance and successful passage of a test on the knowledge of the required curriculum for each attendee;
8. Attendees who can speak and write English must successfully pass a written test with a score of 70% or better;
9. Attendees who cannot speak or write English may be offered a verbal test, provided that the same questions are given as are on the written test and the results of the verbal test are documented with a passing score of 70% or better; and
10. Program providers will solicit effectiveness evaluations from individuals who have completed their program.

As part of the Responsible Vendor program, Liberty Compassion's agents will receive training on a variety of topics relevant to operations, including but not limited to the following:

1. Marijuana's effect on the human body, including physical effects based on different types of marijuana products and methods of administration, and recognizing the visible signs of impairment;
2. Best practices for diversion prevention and prevention of sales to minors;
3. Compliance with tracking requirements;
4. Acceptable forms of identification, including verification of valid photo identification and medical marijuana registration and confiscation of fraudulent identification;
5. Such other areas of training determined by the Commission to be included; and
6. Other significant state laws and rules affecting operators, such as:
 - a. Local and state licensing and enforcement;
 - b. Incident and notification requirements;
 - c. Administrative and criminal liability and license sanctions and court sanctions;
 - d. Waste disposal and health and safety standards;
 - e. Patrons prohibited from bringing marijuana onto licensed premises;
 - f. Permitted hours of sale and conduct of establishment;
 - g. Permitting inspections by state and local licensing and enforcement authorities;
 - h. Licensee responsibilities for activities occurring within licensed premises;
 - i. Maintenance of records and privacy issues; and
 - j. Prohibited purchases and practices.

Health and Sanitation

Liberty Compassion will provide thorough training to all facility employees to mitigate potential sanitation and safety risks. Regular cleaning and sanitation will be provided in all areas.

Health and sanitation training will focus primarily on contamination prevention and employees will learn best practices for preventing contamination of marijuana products from biological contaminants (e.g. parasites, mold, bacteria), physical contaminants (e.g. dirt, dust, glass) and chemical contaminants (e.g. cleaning compounds, sanitizing agents, solvents). Training will primarily focus on the below topics:

1. Inspections – Procedures for inspecting marijuana for signs of damage (e.g. water damage), pests, expiration dates, contamination, etc.
2. Cleaning and sanitizing – Procedures for:
 - a) regular cleaning of equipment, utensils and surfaces to protect against contamination; and
 - b) cleaning and sanitization of display cabinets, countertops and other service areas at the beginning and end of each shift, and throughout the day as needed.
3. Storage of chemicals – Procedures for identifying and storing chemicals, including cleaning compounds, sanitizing agents and solvents.
4. Handling of marijuana – Protocol for proper sanitation and personal hygiene prior to handling any marijuana product.

Health and sanitation training will also include the protocol for handling, storing and disposing of marijuana waste. Additional details related to health and sanitation may be found in the Quality Control and Testing document.

Legal Compliance

Legal compliance training will educate employees on Applicable Law, particularly as Applicable Law informs the day-to-day operations of the Center. Training will cover:

1. Inventory tracking compliance;
2. Required labeling and packaging of marijuana products;
3. Recordkeeping and confidentiality;
4. Prevention of illegal diversion of marijuana; and
5. Disposal of marijuana waste.

Employees will complete initial legal compliance training at new employee orientation and will receive additional training from time-to-time as necessary to track any relevant changes to Applicable Law.

Security

Each employee shall undergo safety and security training during new employee orientation. As a part of the employee orientation process, all employees will be provided with a copy of Security Policies and Procedures and relevant safety reference sheets. Security and safety training shall consist of examination and discussion of the security plan, premises orientation, emergency training, and situational training.

Initial employee safety and security training shall include:

1. Building orientation and access authority which shall include:
 - a) The proper use of employee's access badge for entry into the premises and main building entrance;
 - b) The proper use of employee's access badge for entry into employee's authorized access areas;
 - c) Facility standard business hours and protocol for entry and exit outside standard business hours;
 - d) The proper use of employee's agent card;
 - e) Employee's authorized entry and exit points;

- f) Employee's locker; and
 - g) Restroom and sink facilities.
2. Measures and controls for the prevention of diversion, theft or loss of marijuana which shall include:
 - a) Necessity of keeping all limited access areas always locked and secured;
 - b) Prohibited activities such as entrance into unauthorized access areas;
 - c) Awareness of video monitoring; and
 - d) Requirement to report any unusual activity, security concern, or loitering.
 3. Procedures and instructions for responding to an emergency that will include:
 - a) Accident prevention training;
 - b) How to respond to an emergency;
 - c) Emergency service provider location;
 - d) Emergency service contact information;
 - e) Emergency first aid kit locations; and
 - f) Emergency exits and panic button locations.

Inventory Monitoring and Reporting

Inventory Monitoring and Reporting/Recordkeeping training will focus on making all employees proficient in Liberty Compassion's inventory tracking and point of sale systems and protocols for recordkeeping. Liberty Compassion will utilize the Leaf Logix seed-to-sale system training program and METRC training programs and resources to provide hands-on, situational training to employees on the protocols and procedures required by the Inventory and Recordkeeping Plan.

Product Education

The Company will provide comprehensive training of employees regarding various aspects of marijuana use. Such training will aim to provide all employees with a thorough understanding of the following:

1. The various marijuana strains, and the benefits and drawbacks of each;
2. The various marijuana products and consumption methods, and the benefits and drawbacks of each;
3. The various cannabinoids (including THC and CBD) found in marijuana and the benefits and drawbacks of each;
4. Warnings for different marijuana products. Marijuana product education training sessions will be held periodically to keep employees informed on new marijuana products and information on marijuana strains.

Liberty Compassion Quality Control and Testing Policies & Procedures

Quality Control

Liberty Compassion, Inc. (“Liberty Compassion”) will set and maintain the highest standards of quality control and testing through the implementation of strict operational procedures, establishment of a sanitary and controlled environment, and adherence to both testing requirements and best practices.

Liberty Compassion will ensure that the Liberty Compassion facility is always maintained in a sanitary fashion and will comply with all applicable sanitary requirements. Liberty Compassion sanitizes all designated, applicable areas of the facility, including utensils, equipment and infrastructure, with Cannabis Control Commission (“CCC” or “Commission”) approved cleaning agents as part of daily end-of-day procedures.

Our standard operating procedures for equipment sanitation will include a multipart cleaning process with respect to equipment or instruments that come in contact with marijuana. First, separation of any dried or scrap products that may be around the equipment and surfaces will occur in an ongoing manner throughout the day to avoid buildup from the scrap products. Second, equipment and instruments that come into contact with marijuana will be broken down into component parts with any open equipment panels to be inspected. Third, all equipment and environmental surfaces will be then cleaned with detergent and hot water (between 130 and 160°F, depending on the cleaning chemicals used), and will involve additional steps and multiple cleaning compounds which may contain several ingredients depending on (a) the contamination to be removed, (b) the hardness of water, and (c) the prevention of scale formation on the exposed surfaces. Fourth, detailed documentation/reporting will occur with respect to any failure of not cleaning adequately, product shelf life and quality issues, microbiological problems, regulatory noncompliance, and even closures and other sanctions. Finally, sanitizer application will occur with respect to all cleaned and rinsed surfaces to destroy hidden microorganisms so as to further advance marijuana safety and product stability.

Although cleaning and sterilization are ongoing efforts by staff to virtually eliminate risk of internal and external contaminants, our employees understand that that sanitizing does not replace the need for mitigation of external factors, or the need for thorough handwashing or equipment and facility cleaning – all of which will be implemented by Liberty Compassion. Staff dress in sanitary scrubs at the start of each shift, reducing the threat of external environmental factors. Staff also are required to wash their hands before the start of each shift as they change into work attire in the employee locker rooms. Staff may also wash their hands in any restroom or one of the multiple hand washing stations in the facility. Liberty Compassion agents working at the cultivation facility are subject to the requirements specified in 105 CMR 300.000. Any and all toxic items will be identified, labelled and stored in preventative matter to

ensure there is no contamination with marijuana. Liberty Compassion will comply with the following sanitary requirements:

1. Any marijuana establishment agent whose job includes contact with marijuana or nonedible marijuana products, including cultivation, production, or packaging, is subject to the requirements for food handlers specified in 105 CMR 300.000, and all edible marijuana products will be prepared, handled, and stored in compliance with the sanitation requirements in 105 CMR 500.000, and with the requirements for food handlers specified in 105 CMR 300.000.
2. Any Liberty Compassion agent working in direct contact with preparation of marijuana or nonedible marijuana products shall conform to sanitary practices while on duty, including:
 - a. Maintaining adequate personal cleanliness; and
 - b. Washing hands thoroughly in an adequate hand-washing area before starting work, and at any other time when hands may have become soiled or contaminated.
3. Liberty Compassion's hand-washing facilities will be adequate and convenient and will be furnished with running water at a suitable temperature. Hand-washing facilities will be located in Liberty Compassion's production areas and where good sanitary practices require employees to wash and sanitize their hands, and will provide effective hand-cleaning and sanitizing preparations and sanitary towel service or suitable drying devices;
4. Liberty Compassion's facility will have sufficient space for placement of equipment and storage of materials as is necessary for the maintenance of sanitary operations;
5. Liberty Compassion will ensure that litter and waste is properly removed, disposed of so as to minimize the development of odor and minimize the potential for the waste attracting and harboring pests. The operating systems for waste disposal shall be maintained in an adequate manner pursuant to 935 CMR 500.105(12);
6. Liberty Compassion's floors, walls, and ceilings shall be constructed in such a manner that they may be adequately kept clean and in good repair;
7. Liberty Compassion's facility will have adequate safety lighting in all processing and storage areas, as well as areas where equipment or utensils are cleaned;
8. Liberty Compassion's buildings, fixtures, and other physical facilities will be maintained in a sanitary condition;
9. Liberty Compassion will ensure that all contact surfaces, including utensils and equipment, will be maintained in a clean and sanitary condition. Such surfaces will be cleaned and sanitized as frequently as necessary to protect against contamination, using a sanitizing agent registered by the US Environmental Protection Agency (EPA), in accordance with labeled instructions. Equipment and utensils will be so designed and of such material and workmanship as to be adequately cleanable;
10. All toxic items will be identified, held, and stored in a manner that protects against contamination of marijuana products;
11. Liberty Compassion will ensure that its water supply is sufficient for necessary operations, and that such water supply is safe and potable;
12. Liberty Compassion's plumbing will be of adequate size and design, and adequately installed and maintained to carry sufficient quantities of water to required locations throughout the facility. Plumbing will properly convey sewage and liquid disposable

- waste from the facility. There will be no cross-connections between the potable and waste water lines;
13. Liberty Compassion will provide its employees with adequate, readily accessible toilet facilities that are maintained in a sanitary condition and in good repair;
 14. Liberty Compassion will ensure that any products that can support the rapid growth of undesirable microorganisms are stored or maintained in a manner that prevents the growth of these microorganisms; and
 15. Liberty Compassion will store and transport finished products under conditions that will protect them against physical, chemical, and microbial contamination as well as against deterioration of finished products or their containers.

For Liberty Compassion, quality control also extends to ensuring that rooms housing marijuana exist as sealed systems with clean room properties, and feature air curtains/showers, quarantine rooms with respect to diseased or contaminated products, and the like. All storage areas for marijuana and marijuana products will be outfitted with split ventilation and humid control systems specific to the climate needed in such area to maximize product quality and longevity; subject to clean room standards (air changes, pressurization, and use of HEPA Filters and modular clean room wall panels) to safeguard against pests, mold, chemical agents and the like; and outfitted with carbon/MERV filters.

Liberty Compassion's vehicles and transportation equipment used in the transportation of marijuana products or edibles requiring temperature control for safety will be designed, maintained, and equipped as necessary to provide adequate temperature control to prevent the marijuana products or edibles from becoming unsafe during transportation, consistent with applicable requirements pursuant to 21 CFR 1.908(c).

Liberty Compassion will follow established policies and procedures for handling voluntary and mandatory recalls of marijuana products. Such procedures are sufficient to deal with recalls due to any action initiated at the request or order of the Commission, and any voluntary action by Liberty Compassion to remove defective or potentially defective marijuana products from the market, as well as any action undertaken to promote public health and safety.

Any inventory that becomes outdated, spoiled, damaged, deteriorated, mislabeled, or contaminated will be disposed of in accordance with the provisions of 935 CMR 500.105(12), and any such waste will be stored, secured, and managed in accordance with applicable state and local statutes, ordinances, and regulations.

Liberty Compassion will process marijuana in a safe and sanitary manner. Liberty Compassion will process the leaves and flowers of the female marijuana plant only, which will be:

- Well cured and generally free of seeds and stems;
- Free of dirt, sand, debris, and other foreign matter;
- Free of contamination by mold, rot, other fungus, and bacterial diseases;
- Prepared and handled on food-grade stainless steel tables; and
- Packaged in a secure area.

All edible products will be prepared, handled, and stored in compliance with the sanitation requirements in 105 CMR 590.000: Minimum Sanitation Standards for Food Establishments.

Testing and Sampling

Liberty Compassion will not sell or otherwise market marijuana or marijuana products that are not capable of being tested by Independent Testing Laboratories, except as allowed under 935 CMR 500.000. No marijuana product will be sold or otherwise marketed for adult use that has not first been tested by an Independent Testing Laboratory and deemed to comply with the standards required under 935 CMR 500.160. Testing of Liberty Compassion's marijuana products will be performed by an Independent Testing Laboratory in compliance with the Protocol for Sampling and Analysis of Finished Medical Marijuana Products and Marijuana-infused Products, as amended in November, 2016, published by the DPH. Testing of Liberty Compassion's environmental media will be performed in compliance with the Protocol for Sampling and Analysis of Environmental Media for Massachusetts Registered Medical Marijuana Dispensaries published by the DPH.

Liberty Compassion also plans to conduct internal testing and sampling in-house. Liberty Compassion's internal testing and sampling is not intended to replace testing requirements set by the Commission. All inventory is clearly labelled, helping keep untested product separated from tested product. Inventory undergoing compliance testing is only released upon approved Independent Testing Laboratory test results.

Liberty Compassion's policy of responding to laboratory results that indicate contaminant levels are above acceptable limits established in the DPH protocols identified in 935 CMR 500.160(1) include notifying the Commission within 72 hours of any laboratory testing results indicating that the contamination cannot be remediated and disposing of the production batch. Such notification will describe a proposed plan of action for both the destruction of the contaminated product and the assessment of the source of contamination.

Liberty Compassion will maintain testing results in compliance with 935 CMR 500.000 *et seq* and the recordkeeping policies described herein and will maintain the results of all testing for no less than one year.

All transportation of marijuana to and from Independent Testing Laboratories providing marijuana testing services will comply with 935 CMR 500.105(13). Extended procedures may be found in the Transportation of Marijuana document. All storage of Liberty Compassion's marijuana at a laboratory providing marijuana testing services will comply with 935 CMR 500.105 (11). All excess marijuana will be disposed of in compliance with 935 CMR 500.105(12), either by the Independent Testing Laboratory returning excess marijuana to Liberty Compassion for disposal or by the Independent Testing Laboratory disposing of it directly.

Liberty Compassion Record Keeping Procedures Policies & Procedures

General Overview

Liberty Compassion, Inc. (“Liberty Compassion”) has established policies regarding record-keeping and record-retention in order to ensure the maintenance, safe keeping and accessibility of critical documents. Electronic and wet signatures are accepted forms of execution of Liberty Compassion documents. Records will be stored at Liberty Compassion in a locked room designated for record retention. All applicable records will be available for inspection by the Cannabis Control Commission (“CCC”) upon request pursuant to 935 CMR 500.

Record-Keeping

To ensure that Liberty Compassion is keeping and retaining all records as noted in this policy, reviewing Corporate Records, Business Records, and Personnel Records to ensure completeness, accuracy and timeliness will occur as part of Liberty Compassion’s quarter-end closing procedures. In addition, operating procedures will be updated on an ongoing basis as needed and undergo a review by the executive management team on an annual basis. Liberty Compassion will maintain records in accordance with generally accepted accounting principles per 935 CMR 500.105(9).

- Corporate Records are defined as those records that require, at a minimum, annual reviews, updates, and renewals, including:
 - Insurance Coverage
 - Directors & Officers Policy
 - Product Liability Policy
 - General Liability Policy
 - Umbrella Policy
 - Workers Compensation Policy
 - Employer Professional Liability Policy
 - Third-Party Laboratory Contracts
 - Commission Requirements:
 - Annual Agent Registration
 - Annual Marijuana Establishment Registration
 - Local Compliance
 - Certificate of Occupancy
 - Special Permits
 - Variances
 - Site Plan Approvals
 - As-Built Drawings
 - Corporate Governance:
 - Annual Report
 - Secretary of State Filings

- Business Records are defined as those which require ongoing maintenance and updates. Liberty Compassion's Chief Executive Officer maintains access to all business records. Liberty Compassion maintains records in accordance with generally accepted accounting principles per 935 CMR 500.105(9). These records can be electronic or hard copy although preferably electronic copy and at minimum include:
 - Assets and liabilities;
 - Monetary transactions;
 - Books of accounts, which will include journals, ledgers, and supporting documents, agreements, checks, invoices, and vouchers;
 - Sales records including the quantity, form, and cost of marijuana products; and
 - Salary and wages paid to each agent, stipend paid to each board member, and any executive compensation, bonus, benefit, or item of value paid to any individual affiliated with Liberty Compassion, including members, if any.
 - List of all board members and executives of Liberty Compassion, and members, if any, must be made available upon request by any individual.
- Personnel Records are maintained as a separate category considering the importance of the background checks on agents and well as agent registration status and at a minimum will include:
 - Job descriptions for each agent and volunteer, as well as organizational charts consistent with the job descriptions;
 - A personnel record for each marijuana establishment agent. Such records will be maintained for at least twelve (12) months after termination of the agent's affiliation with Liberty Compassion and will include, at a minimum, the following:
 - All materials submitted to the CCC pursuant to 935 CMR 500.030(2);
 - Documentation of verification of references;
 - The job description or employment contract that includes duties, authority, responsibilities, qualifications, and supervision;
 - Documentation of all required training, including training regarding privacy and confidentiality requirements, and the signed statement of the individual indicating the date, time, and place he or she received said training and the topics discussed, including the name and title of presenters;
 - A copy of the application that Liberty Compassion submitted to the CCC on behalf of any prospective Liberty Compassion agent;
 - Documentation of periodic performance evaluations; and
 - A record of any disciplinary action taken.
 - Notice of completed responsible vendor and eight-hour related duty training
 - A staffing plan that will demonstrate accessible business hours and safe cultivation conditions;
 - Personnel policies and procedures; and
 - All background check reports obtained in accordance with 935 CMR 500.030.
- Handling and Testing of Marijuana Records

- Liberty Compassion will maintain the results of all testing for a minimum of (1) year;
- Inventory Records
 - Inventory records will be pursuant to 935 CMR 500.105(8). Comprehensive inventories of marijuana in process of cultivation, finished, and stored marijuana will occur at least monthly. The record of each inventory will include, at a minimum, the date of the inventory, a summary of the inventory findings, and the names, signatures, and titles of the agents who conducted the inventory.
- Seed-to-Sale Tracking Records for all marijuana as required by 935 CMR 500.105(8)(e) and 935 CMR 500.105(9).
 - Liberty Compassion will use Metrc as their primary seed-to-sale tracking software to maintain real-time inventory. LeafLogix will be utilized as a secondary system. Inventory reporting will meet the requirements specified by the CCC and 935 CMR 500.105(9)(c). Inventory reporting will meet the requirements specified by the Commission and 935 CMR 500.105(8)(c) and (d), including, at a minimum, an inventory of marijuana ready for dispensing; all marijuana products; and all damaged, defective, expired, or contaminated marijuana and marijuana products awaiting disposal.
- Incident Reporting Records
 - Within ten (10) calendar days, Liberty Compassion will provide written notice to the CCC of any incident described in 935 CMR 500.110(7)(a) by submitting an incident report, detailing the incident, the investigation, the findings, resolution (if any), confirmation that the Clinton Police Department and Commission were notified within twenty-four (24) hours of discovering the breach, and any other relevant information. . Reports, and supporting documents, including photos and surveillance video related to a reportable incident will be maintained by Liberty Compassion for no less than one year or the duration of an open investigation, whichever is longer, and made available to the Commission and to law enforcement authorities acting within their lawful jurisdiction upon request.
- Visitor Records
 - A visitor sign-in and sign-out record will be maintained at the security office. The record will include the visitor's name, address, organization or firm, date, time in and out, and the name of the authorized agent who will be escorting the visitor.
- Waste Disposal Records
 - When marijuana or marijuana products are disposed of, Liberty Compassion will create and maintain a written record of the date, the type and quantity disposed of or handled, the manner of disposal or other handling, the location of disposal or other handling, and the names of the two Liberty Compassion agents present during the disposal or handling, with their signatures.
 - Liberty Compassion will keep disposal records for at least three (3) years. This period will automatically be extended for the duration of any enforcement action and may be extended by an order of the Commission.
- Security Records
 - A current list of authorized agents and service personnel that have access to the surveillance room will be available to the Commission upon request.

- Twenty-four (24) hour recordings from all video cameras that are available for immediate viewing by the Commission upon request and that are retained for at least ninety (90) calendar days.
- Transportation Records
 - Liberty Compassion will retain all shipping manifests for a minimum of one (1) year and make them available to the Commission upon request.
- Agent Training Records
 - Documentation of all required training, including training regarding privacy and confidentiality requirements, and a signed statement from the agent indicating the date, time, and place he or she received the training, the topics discussed and the name and title of the presenter(s).
- Closure
 - In the event Liberty Compassion closes, all records will be kept for at least two (2) years at Liberty Compassion's expense in a form (electronic, hard copies, etc.) and location acceptable to the Commission. In addition, Liberty Compassion will communicate with the Commission during the closure process and accommodate any additional requests the Commission or other agencies may have.
- Written Operating Policies and Procedures: Policies and Procedures related to Liberty Compassion's operations will be updated on an ongoing basis as needed and undergo a review by the executive management team on an annual basis. Policies and Procedures include the following:
 - Security measures in compliance with 935 CMR 500.110;
 - Agent security policies, including personal safety and crime prevention techniques;
 - A description of Liberty Compassion's hours of operation and after-hours contact information, which will be provided to the Commission, made available to law enforcement officials upon request, and updated pursuant to 935 CMR 500;
 - Storage of marijuana in compliance with 935 CMR 500.105(11);
 - Description of the various strains of marijuana to be cultivated, processed or sold, as applicable, and the form(s) in which marijuana will be dispensed;
 - Procedures to ensure accurate recordkeeping, including inventory protocols in compliance with 935 CMR 500.160;
 - Plans for quality control, including product testing for contaminants in compliance with 935 CMR 500.160;
 - A staffing plan and staffing records in compliance with 935 CMR 500.105(9);
 - Emergency procedures, including a disaster plan with procedures to be followed in case of fire or other emergencies;
 - Alcohol, smoke, and drug-free workplace policies;
 - A plan describing how confidential information will be maintained;
 - Policy for the immediate dismissal of any marijuana establishment agent who has:
 - Diverted marijuana, which shall be reported to law enforcement officials and to the Commission;
 - Engaged in unsafe practices with regard to Liberty Compassion's operations, which shall be reported to the Commission; or
 - Been convicted or entered a guilty plea, plea of *nolo contendere*, or admission to sufficient facts of a felony drug offense involving distribution to a minor in

the Commonwealth, or a like violation of the laws of another state, the United States or foreign jurisdiction, or a military, territorial, or Native American tribal authority.

- A list of all executives of Liberty Compassion to be available upon requires by any individual. 935 CMR 500.105(1)(m) requirement may be fulfilled by placing this information on Liberty Compassion's website.
- Policies and procedures for the handling of cash on Liberty Compassion's premises including but not limited to storage, collection frequency and transport to financial institution(s).
- Policies and procedures to prevent the diversion of marijuana to individuals younger than 21 years old.
- Policies and procedures for energy efficiency and conservation that will include:
 - Identification of potential energy use reduction opportunities (including but not limited to natural lighting, heat recovery ventilation and energy efficiency measures), and a plan for implementation of such opportunities;
 - Consideration of opportunities for renewable energy generation, including, where applicable, submission of building plans showing where energy generators could be placed on the site, and an explanation of why the identified opportunities were not pursued, if applicable
 - Strategies to reduce electric demand (such as lighting schedules, active load management and energy storage); and
 - Engagement with energy efficiency programs offered pursuant to M.G.L. c. 25, § 21 or through municipal lighting plants
-

Record-Retention

Liberty Compassion will meet Commission recordkeeping requirements and retain a copy of all records for two (2) years, unless otherwise specified in the regulations. All digital records will be backed up, thereby ensuring the integrity of our records in the event of a technological failure. Paper documentation will be stored in fireproof file cabinets located in a limited access area and available only to our authorized personnel.

Audits

Liberty Compassion audits will be documented to include the date, time and agent(s) responsible for the audit. At a minimum, the following audits will be conducted.

- Inventory
 - Inventory audits to be conducted on a daily basis at the retail licensed establishments to ensure any reconciliation and investigations are completed the same day.
 - A full inventory audit to be conducted, at a minimum, every 30 days.
- Security
 - On an annual basis, Liberty Compassion will obtain, at its own expense, a security system audit.

- This report will be submitted to the Commission, no later than 30 days after the audit is conducted.
- All security equipment will be in good working order and will be inspected and tested at regular intervals, not to exceed 30 calendar days from the previous inspection and test.
 - This includes generators used to ensure the security system remains operational in the event of a power outage

Liberty Compassion Restricting Access to Age 21 and Older Policies & Procedures

Overview

In alignment with the emphasis placed on restricting the accessibility of Marijuana Establishments to those 21 years old and older, Liberty Compassion, Inc. (“Liberty Compassion”) has policies and procedures in place to meet the requirements set by the Cannabis Control Commission (“Commission or CCC”). Pursuant to 935 CMR 500.050(5)(b), Liberty Compassion facilities will only be accessible to individuals 21 years of age or older with a verified and valid, government-issued photo ID. Upon entry to the Liberty Compassion facility premises, a Liberty Compassion agent will immediately inspect an individual’s proof of identification and determine the individual’s age, in accordance with 935 CMR 500.140(2). Individuals who cannot provide a valid, government-issued photo ID will be denied access past the security, check-in desk and asked to leave.

Main Entrance Check-In Duties

In the Liberty Compassion facility, there is a mantrap immediately following the main entrance where individuals check in. Every Liberty Compassion Marijuana Establishment will always have at least one Security agent present at a check-in desk during business hours. The security room is located adjacent to the mantrap and has a window to allow for communication. From this security room, Security personnel are able to monitor camera active around the facility as well as confirm the required government ID’s for all customers or visitors.

All IDs must be current (unexpired), and there are no exceptions made regarding accepted photo IDs. Forms of government-issued photo IDs accepted by Liberty Compassion are:

- Driver’s License
- Government-Issued ID Card
- Military ID card
- Passport or Passport ID Card

Liberty Compassion Agents also must check in by providing their government issued ID and Liberty Compassion credentials. Once confirmed, the Liberty Compassion Agent may enter the locker rooms and proceed with their daily duties. If the individual requesting access is a contractor or visitor with a reasonable need to visit (deliveries, interviews, repairs, etc.), they must follow the Liberty Compassion procedure for Contractor/Visitor access. For more about this procedure, see the Security Plan document within the relevant application packet section.

General Accessibility

Liberty Compassion’s cultivation facility will have enclosed, locked egress doors to the operations accessible only to cultivation/manufacturing agents, law enforcement personnel, regulatory commission officials and security personnel. The access points will be monitored by surveillance cameras and there will be prominent signage indicating limited access areas. The entrance to the cultivation facility will be protected by using a swipe card system that date stamps the entrance database with the pertinent access information for every user. We will positively identify

individuals seeking access to the premises of our marijuana establishment and while our marijuana products are being transported and limit access solely to individuals 21 years of age or older. We allow only authorized individuals access into our marijuana establishment, and outside vendors, contractors, and visitors must obtain and display an identification badge and will be escorted at all times.

All emergency exits and access points are secure and locked during both business and non-business hours with cameras angled to properly monitor those areas. Liberty Compassion security specifics, such as the facility's alarm and surveillance systems, can be found within the Security Plan document within the relevant application section. Liberty Compassion will remain compliant with accessibility rules outlined by the Commission and 935 CMR 500.110, with a heightened focus on the restriction of access to those under 21 years old.

Liberty Compassion will not hire as agents any individuals who are under the age of 21 or who have been convicted of distribution of controlled substances to minors.

In compliance with state regulations, Liberty Compassion will not engage in any marketing, advertising or branding practices that are targeted to, deemed to appeal to or portray minors under the age of 21. Liberty Compassion will not engage in any advertising, marketing and branding by means of television, radio, internet, mobile applications, social media, or other electronic communication, billboard or other outdoor advertising, including charitable, sporting or similar events, unless at least 85% of the audience is reasonably expected to be 21 years of age or older as determined by reliable and current audience data.

Liberty Compassion will not manufacturer or sell any edible products that resemble a realistic or fictional human, animal or fruit, including artistic, caricature or cartoon renderings that may be attractive to minors. In accordance with state regulations, any adult use marijuana marketing, advertising and branding materials for public viewing will include a warning stating, **“For use only by adults 21 years of age or older. Keep out of the reach of children.”**

Liberty Compassion's packaging will be tamper or child-resistant, and will not use bright colors, resemble existing branded products, feature cartoons or celebrities commonly used to market products to minors, feature images of minors or other words that refer to products commonly associated with minors or otherwise be attractive to minors.

Liberty Compassion's website will require all online visitors to verify they are 21 years of age or older prior to accessing the website.

Positive Impact Plan

This Positive Impact Plan will outline how Liberty Compassion Inc. (“Liberty”) will address the Goals, Programs, and Measurements defined by the Cannabis Control Commission (“CCC” or “Commission”) to positively support areas (geographies) of disproportionate impact. Liberty is dedicated to supporting populations falling within areas of disproportionate impact and will support charity and community initiatives. Liberty firmly believes that to achieve a spirit of cooperation and friendship with local communities, leadership must help drive and continuously support these company initiatives.

Liberty’s Positive Impact Plan has identified and created goals and programs to support residents of the City of Fitchburg and in areas of disproportionate impact within Worcester. Both locations are approximately 30 minutes from Liberty’s Cultivation and Manufacturing facility in Clinton, MA. These will be referred to as “Impact Areas” in the following Plan.

Goals

In order for Liberty to positively impact the above communities, Liberty has established the following goals:

1. Reducing barriers to entry in the commercial adult-use cannabis industry; and
2. Providing business assets towards endeavors in these Impact Areas that will have a positive impact on members of these communities

Programs

Liberty has developed specific programs to effectuate its stated goals to positively contribute to Impact Areas. The below details actions, activities, and processes that will be utilized to achieve the outlined goals of Liberty:

1. Instituting a preferential hiring program for Impact Areas. This will include ongoing outreach at Impact Area-based career fairs and posting available job positions in Impact Area publications and websites to attract residents (e.g. Worcester Telegram & Gazette and Sentinel & Enterprise);
2. Hosting bi-annual job fairs in Impact Areas, this will also include networking through the Nashoba Valley Chamber of Commerce which has relationships with the surrounding chambers, to advertise the job fairs and post job openings;
3. Holding an annual in-store holiday food drive, donating through sponsorship opportunities and direct giving (such as Dismas House in Worcester whose mission is to help former prisoners transition into society), and providing opportunities for Liberty employees to participate in ongoing community service volunteer work in Impact Areas (e.g. soup kitchen, food pantry, and local trash pickup); and
4. Organizing or hosting three industry-specific educational seminars, trainings, or skill development events on cannabis business management and retailing and related skills annually.

Measurements

Liberty has outlined methods in which the goals and programs will be tracked and measured for success. Human Resources will administer the Plan to Positively Impact Areas of Disproportionate Impact and will be responsible for measuring and reporting outcomes to ensure Liberty continues to meet its commitments. Measuring the success of these programs is critical in being able to accurately report to the Commission when applying to renew Liberty's license.

These measurable outcomes include:

- Ensuring that at least 10% of Clinton facility staff members are from Impact Areas. Human Resources will record individuals' home address at the time of employment and provide regular staffing audits and reports of employees hired, retained, and promoted who are past or present residents of Impact Areas;
- Documenting and reporting on donations, community service hours, in-store drives, and sponsorship activities.
 - Ensuring that Liberty donates a total of \$10,000 in its first year of adult use operations to charities. Liberty has already committed to an initial donation of \$1,000 to Dismas House. In order for Liberty to consider partnering with another non-profit or charity in addition to Dismas House, it would need to have a mission of improving one of the disproportionately impacted areas as identified by the Commission.
 - Ensuring that Liberty, as an organization, completes 100 hours of volunteer community service work in Impact Areas.
- Accounting will track any financial support provided including dates, items donated, and individuals or entities to whom the donation or sponsorship was provided;
- Measuring volunteer hours will be simple through Liberty's time reporting system. Liberty will provide quarterly opportunities for employees to volunteer with organizations contributing to communities in Impact Areas, tracked by attendance. If employees feel strongly about an alternative organization, however, they may suggest it to Liberty. After ensuring the authenticity of the group to confirm time spent is positively impacting an appropriate area, Liberty will provide a time reporting form, listing hours, work done, and signature from an on-site volunteer manager. Annual recognition to employees choosing to volunteer will encourage participation.
- Documenting and reporting on the number and topic of industry-specific educational seminars, trainings, or skill development events, including attendee lists, provided handouts, and amount of resources spent for each event

In the event that Liberty is not meeting its stated commitments, Liberty will solicit company-wide feedback on existing programs and ways to better address the needs of residents in Impact Areas.

In execution of its Positive Impact Plan, Liberty will adhere to the requirements set forth in 935 CMR 500.105(4) which provides the permitted and prohibited advertising, branding, marketing, and sponsorship practices of Marijuana Establishments. Any actions taken, or programs instituted by Liberty will not violate the Commission's regulations with respect to limitations on ownership or control or other applicable state laws.